

TOSHIBA

SERVICE MANUAL

MULTIFUNCTIONAL DIGITAL SYSTEMS
e-STUDIO555/655/755/855



Model: DP-5550/6550/7550/8550
Publish Date: April 2009
File No. SME080016E0
R081221H1100-TTEC
Ver05_2011-05

Trademarks

- The official name of Windows XP is Microsoft Windows XP Operating System.
- The official name of Windows 7 is Microsoft Windows 7 Operating System.
- Microsoft, Windows, Windows NT, Windows Vista and the brand names and product names of other Microsoft products are trademarks or registered trademarks of Microsoft Corporation in the U.S. and/or other countries.
- Apple, AppleTalk, Macintosh, and Mac are trademarks of Apple Computer, Inc. in the U.S. and other countries.
- PostScript is a trademark of Adobe Systems Incorporated.
- NOVELL, NetWare, and NDS are trademarks or registered trademarks of Novell, Inc.
- Molykote is a registered trademark of Dow Corning Corporation.
- Mylar is a registered trademark of DuPont Teijin Films U.S. Limited Partnership.
- FLOIL is a registered trademark of Kanto Kasei Ltd. CORPORATION
- iCLASS is a trademark of HID Corporation.
- MIFARE is a trademark of Royal Philips Electronics.
- Other company names and product names in this manual are the trademarks of their respective companies.

© 2009 - 2011 TOSHIBA TEC CORPORATION All rights reserved

Under the copyright laws, this manual cannot be reproduced in any form without prior written permission of TOSHIBA TEC CORPORATION. No patent liability is assumed, however, with respect to the use of the information contained herein.

GENERAL PRECAUTIONS REGARDING THE SERVICE FOR e-STUDIO555/655/755/855

The installation and service should be done by a qualified service technician.

1. Transportation/Installation

- When transporting/installing the equipment, employ four persons and be sure to move it by the casters while lifting the stoppers.
The equipment is quite heavy and weighs approximately 202 kg (445 lb.), therefore pay full attention when handling it.
- Be sure not to hold the movable parts or units (e.g. the RADF) when transporting the equipment.
- Be sure to use a dedicated outlet with AC 110 V / 16 A, AC 115 V / 16 A, 127 V / 16 A, 220 V or 220-240 V / 9 A for its power source.
- The equipment must be grounded for safety.
- Select a suitable place for installation. Avoid excessive heat, high humidity, dust, vibration and direct sunlight.
- Provide proper ventilation since the equipment emits a slight amount of ozone.
- To insure adequate working space for the copying operation, keep a minimum clearance of 80 cm (32") on the left, 80 cm (32") on the right and 10 cm (4") on the rear.
- The equipment shall be installed near the socket outlet and shall be accessible.
- Be sure to fix and plug in the power cable securely after the installation so that no one trips over it.

2. General Precautions at Service

- Be sure to turn the power OFF and unplug the power cable during service (except for the service should be done with the power turned ON).
- Unplug the power cable and clean the area around the prongs of the plug and socket outlet once a year or more. A fire may occur when dust lies on this area.
- When the parts are disassembled, reassembly is the reverse of disassembly unless otherwise noted in this manual or other related documents. Be careful not to install small parts such as screws, washers, pins, E-rings, star washers in the wrong places.
- Basically, the equipment should not be operated with any parts removed or disassembled.
- The PC board must be stored in an anti-electrostatic bag and handled carefully using a wristband since the ICs on it may be damaged due to static electricity.

Caution: Before using the wristband, unplug the power cable of the equipment and make sure that there are no charged objects which are not insulated in the vicinity.

- Avoid expose to laser beam during service. This equipment uses a laser diode. Be sure not to expose your eyes to the laser beam. Do not insert reflecting parts or tools such as a screwdriver on the laser beam path. Remove all reflecting metals such as watches, rings, etc. before starting service.
- Be sure not to touch high-temperature sections such as the exposure lamp, fuser unit, damp heater and areas around them.
- Be sure not to touch high-voltage sections such as the chargers, transfer belt, IH control circuit, developer, high-voltage transformer, exposure lamp control inverter, inverter for the LCD backlight and power supply unit. Especially, the board of these components should not be touched since the electric charge may remain in the capacitors, etc. on them even after the power is turned OFF.
- Make sure that the equipment will not operate before touching potentially dangerous places (e.g. rotating/operating sections such as gears, belts pulleys, fans and laser beam exit of the laser optical unit).
- Be careful when removing the covers since there might be the parts with very sharp edges underneath.
- When servicing the equipment with the power turned ON, be sure not to touch live sections and rotating/operating sections. Avoid exposing your eyes to laser beam.
- Use designated jigs and tools.

- Use recommended measuring instruments or equivalents.
- Return the equipment to the original state and check the operation when the service is finished.
- Be very careful to treat the touch panel gently and never hit it. Breaking the surface could cause malfunctions.

3. Important Service Parts for Safety

- The breaker, door switch, fuse, thermostat, thermofuse, thermistor, batteries, IC-RAMs including lithium batteries, etc. are particularly important for safety. Be sure to handle/install them properly. If these parts are short-circuited and their functions become ineffective, they may result in fatal accidents such as burnout. Do not allow a short-circuit or do not use the parts not recommended by Toshiba TEC Corporation.

4. Cautionary Labels

- During servicing, be sure to check the rating plate and cautionary labels such as “Unplug the power cable during service”, “CAUTION. HOT”, “CAUTION. HIGH VOLTAGE”, “CAUTION. LASER BEAM”, etc. to see if there is any dirt on their surface and if they are properly stuck to the equipment.

Identification label

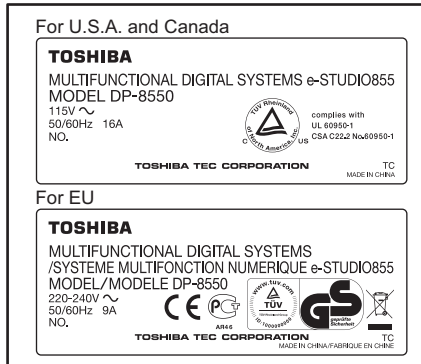

Explanatory label



Certification label (For U.S.A. and Canada)

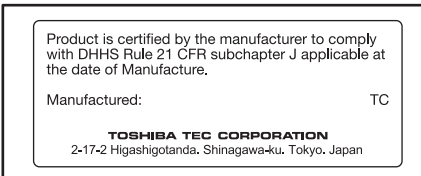

Warning label

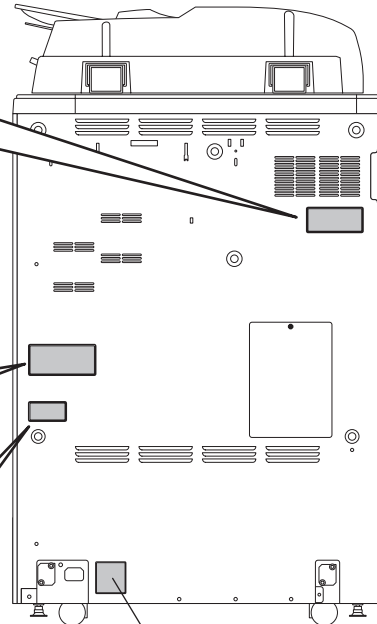

Warning for grounding wire

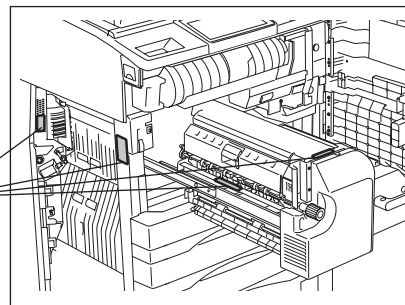
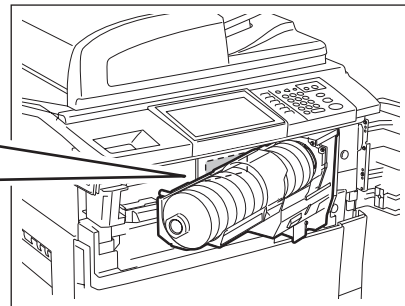

Warning for high temperature areas

5. Disposal of the Equipment, Supplies, Packing Materials, Used Batteries and IC-RAMs

- Regarding the recovery and disposal of the equipment, supplies, packing materials, used batteries and IC-RAMs including lithium batteries, follow the relevant local regulations or rules.

Caution:

Dispose of used batteries and IC-RAMs including lithium batteries according to this manual.

Attention:

Se débarrasser de batteries et IC-RAMs usés y compris les batteries en lithium selon ce manuel.

Vorsicht:

Entsorgung des gebrauchten Batterien und IC-RAMs (inclusive der Lithium-Batterie) nach diesem Handbuch.

ALLEGEMEINE SICHERHEITSMASSNAHMEN IN BEZUG AUF DIE WARTUNG FÜR e-STUDIO555/655/755/855

Die Installation und die Wartung sind von einem qualifizierten Service-Techniker durchzuführen.

1. Transport/Installation

- Zum Transportieren/Installieren des Gerätes werden 4 Personen benötigt. Nur an den in der Abbildung gezeigten Stellen tragen.
Das Gerät ist sehr schwer und wiegt etwa 202 kg (445 lb.); deshalb muss bei der Handhabung des Geräts besonders aufgepasst werden.
- Beim Transportieren des Geräts nicht an den beweglichen Teilen oder Einheiten (z.B. das Bedienungsfeld, die Duplexeinheit oder die automatische Dokumentenzuführung) halten.
- Eine spezielle Steckdose mit Stromversorgung von AC 110 V / 16 A, AC 115 V / 16 A, 127 V / 16 A, 220 V oder 220-240 V / 9 A als Stromquelle verwenden.
- Das Gerät ist aus Sicherheitsgründen zu erden.
- Einen geeigneten Standort für die Installation wählen. Standorte mit zuviel Hitze, hoher Luftfeuchtigkeit, Staub, Vibrieren und direkter Sonneneinstrahlung sind zu vermeiden.
- Für ausreichende Belüftung sorgen, da das Gerät etwas Ozon abgibt.
- Um einen optimalen Kopierbetrieb zu gewährleisten, muss ein Abstand von mindestens 80 cm links, 80 cm rechts und 10 cm dahinter eingehalten werden.
- Das Gerät ist in der Nähe der Steckdose zu installieren; diese muss leicht zu erreichen sein.
- Nach der Installation muss das Netzkabel richtig hineingesteckt und befestigt werden, damit niemand darüber stolpern kann.
- Falls der Auspackungsstandort und der Installationsstandort des Geräts verschieden sind, die Bildqualitätsjustierung (automatische Gammajustierung) je nach der Temperatur und Luftfeuchtigkeit des Installationsstandorts und der Papiersorte, die verwendet wird, durchführen.

2. Allgemeine Sicherheitsmassnahmen in bezug auf die Wartung

- Während der Wartung das Gerät ausschalten und das Netzkabel herausziehen (ausser Wartung, die bei einem eingeschalteten Gerät, durchgeführt werden muss).
- Das Netzkabel herausziehen und den Bereich um die Steckerpole und die Steckdose die Umgebung in der Nähe von den Steckerzacken und der Steckdose wenigstens einmal im Jahr reinigen. Wenn Staub sich in dieser Gegend ansammelt, kann dies ein Feuer verursachen.
- Wenn die Teile auseinandergenommen werden, wenn nicht anders in diesem Handbuch usw erklärt, ist das Zusammenbauen in umgekehrter Reihenfolge durchzuführen. Aufpassen, dass kleine Teile wie Schrauben, Dichtungsringe, Bolzen, E-Ringe, Stern-Dichtungsringe, Kabelbäume nicht an den verkehrten Stellen eingebaut werden.
- Grundsätzlich darf das Gerät mit entfernten oder auseinandergenommenen Teilen nicht in Betrieb genommen werden.
- Das PC-Board muss in einer Anti-elektrostatischen Hülle gelagert werden. Nur Mit einer Manschette bei Betätigung eines Armbandes anfassen, sonst könnte es sein, dass die integrierten Schaltkreise durch statische Elektrizität beschädigt werden.
Vorsicht: Vor Benutzung der Manschette der Betätigung des Armbandes, das Netzkabel des Gerätes herausziehen und prüfen, dass es in der Nähe keine geladenen Gegenstände, die nicht isoliert sind, gibt.
- Setzen Sie sich während der Wartungsarbeiten nicht dem Laserstrahl aus. Dieses Gerät ist mit einer Laserdiode ausgestattet. Es ist unbedingt zu vermeiden, direkt in den Laserstrahl zu blicken. Keine reflektierenden Teile oder Werkzeuge, wie z. B. Schraubendreher, in den Pfad des Laserstrahls halten. Vor den Wartungsarbeiten sämtliche reflektierenden Metallgegenstände, wie Uhren, Ringe usw., entfernen.
- Auf keinen Fall Hochtemperaturbereiche, wie die Belichtungslampe, die Fixiereinheit, die Heizquelle und die umliegenden Bereiche, berühren.

- Auf keinen Fall Hochspannungsbereiche, wie die Ladeeinheiten, das Transferband, IH-Kontrollstrom, die Entwicklereinheit, den Hochspannungstransformator, den Steuerumrichter für die Belichtungslampe, den Umrichter für die LCD-Hintergrundbeleuchtung und das Netzgerät, berühren. Insbesondere sollten die Platinen dieser Komponenten nicht berührt werden, da die Kondensatoren usw. auch nach dem Ausschalten des Geräts noch elektrisch geladen sein können.
- Vor dem Berühren potenziell gefährlicher Bereiche (z. B. drehbare oder betriebsrelevante Bereiche, wie Zahnräder, Riemen, Riemenscheiben, Lüfter und die Laseraustrittsöffnung der optischen Lasereinheit) sicherstellen, dass das Gerät sich nicht bedienen lässt.
- Beim Entfernen von Abdeckungen vorsichtig vorgehen, da sich darunter scharfkantige Komponenten befinden können.
- Bei Wartungsarbeiten am eingeschalteten Gerät dürfen keine unter Strom stehenden, drehbaren oder betriebsrelevanten Bereiche berührt werden. Nicht direkt in den Laserstrahl blicken.
- Ausschließlich vorgesehene Werkzeuge und Hilfsmittel verwenden.
- Empfohlene oder gleichwertige Messgeräte verwenden.
- Nach Abschluss der Wartungsarbeiten das Gerät in den ursprünglichen Zustand zurück versetzen und den einwandfreien Betrieb überprüfen.
- Das berührungsempfindliche Bedienungsfeld stets vorsichtig handhaben und keinen Stößen aussetzen. Wenn die Oberfläche beschädigt wird, kann dies zu Funktionsstörungen führen.

3. Sicherheitsrelevante Wartungsteile

- Der Leistungsschutzschalter, der Türschalter, die Sicherung, der Thermostat, die Thermosicherung, der Thermistor, die IC-RAMs einschließlich der Lithiumakkus usw. sind besonders sicherheitsrelevant. Sie müssen unbedingt korrekt gehandhabt und installiert werden. Wenn diese Teile kurzgeschlossen und funktionsunfähig werden, kann dies zu schwerwiegenden Schäden, wie einem Abbrand, führen. Kurzschlüsse sind zu vermeiden, und es sind ausschließlich Teile zu verwenden, die von der Toshiba TEC Corporation empfohlen sind.

4. Warnetiketten

- Im Rahmen der Wartung unbedingt das Leistungsschild und die Etiketten mit Warnhinweisen überprüfen [z. B. „Unplug the power cable during service“ („Netzkaabel vor Beginn der Wartungsarbeiten abziehen“), „CAUTION. HOT“ („VORSICHT, HEISS“), „CAUTION. HIGH VOLTAGE“ („VORSICHT, HOCHSPANNUNG“), „CAUTION. LASER BEAM“ („VORSICHT, LASER“) usw.], um sicherzustellen, dass sie nicht verschmutzt sind und korrekt am Gerät angebracht sind.

Identification label

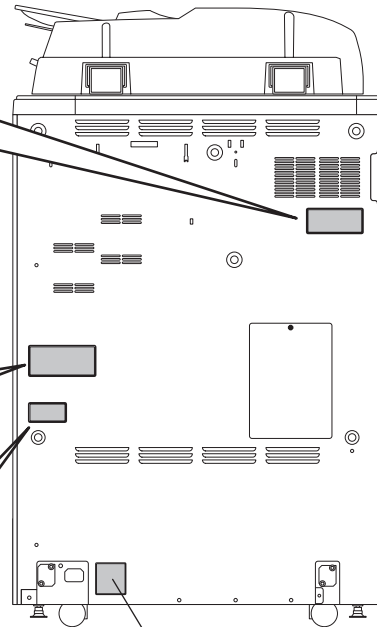
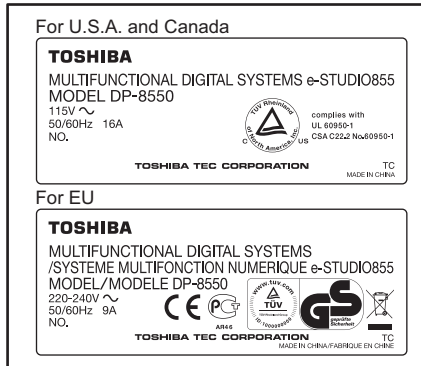

Explanatory label



Certification label (For U.S.A. and Canada)



Warning for grounding wire

Warning label

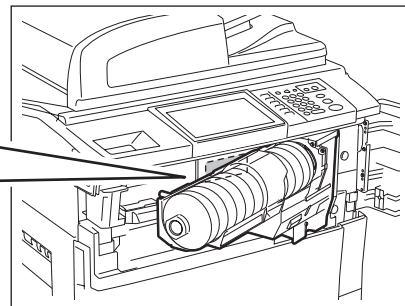
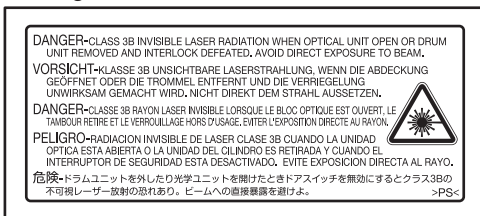

Warning for high temperature areas

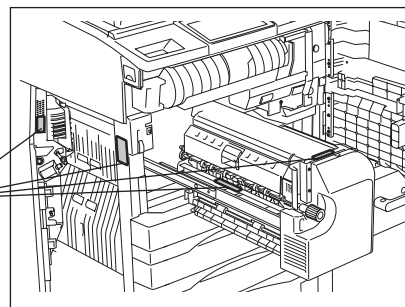

5. Entsorgung des Geräts, der Verbrauchs- und Verpackungsmaterialien, alter Akkus und IC-RAMs

- In Bezug auf die Entsorgung und Wiederverwertung des Geräts, der Verbrauchs- und Verpackungsmaterialien, alter Akkus und IC-RAMs, einschließlich Lithiumakkus, sind die einschlägigen nationalen oder regionalen Vorschriften zu befolgen.

Caution:

Dispose of used batteries and IC-RAMs including lithium batteries according to this manual.

Attention:

Se débarrasser de batteries et IC-RAMs usés y compris les batteries en lithium selon ce manuel.

Vorsicht:

Entsorgung des gebrauchten Batterien und IC-RAMs (inclusive der Lithium-Batterie) nach diesem Handbuch.

CONTENTS

1. SPECIFICATIONS/ACCESSORIES/OPTIONS/SUPPLIES	1-1
1.1 Specifications	1-1
1.1.1 General	1-1
1.1.2 Copy	1-4
1.1.3 Print	1-13
1.1.4 Scan	1-13
1.1.5 e-Filing	1-13
1.1.6 Internet Fax	1-14
1.1.7 Network Fax	1-15
1.2 Accessories	1-16
1.3 Options	1-17
1.4 Supplies	1-18
1.5 System List	1-19
2. OUTLINE OF THE MACHINE	2-1
2.1 Sectional View	2-1
2.1.1 Front view	2-1
2.1.2 Rear view	2-4
2.2 Electric Parts Layout	2-7
2.3 Symbols and Functions of Various Components	2-31
2.3.1 Motors	2-31
2.3.2 Sensors and switches	2-33
2.3.3 Electromagnetic spring clutches	2-36
2.3.4 Solenoids	2-37
2.3.5 PC boards	2-37
2.3.6 Lamps and heaters	2-38
2.3.7 Thermistors and thermostats	2-38
2.3.8 Transformer	2-39
2.3.9 Others	2-39
2.4 System Block Diagram	2-40
2.5 Installation and Replacement of Covers	2-41
2.6 Removal and Installation of Options	2-46
3. COPY PROCESS	3-1
3.1 General Description	3-1
3.2 Details of Copy Process	3-2
3.3 Comparison of Copy Process to e-STUDIO550/650/810	3-11
4. GENERAL OPERATION	4-1
4.1 Overview of Operation	4-1
4.2 Description of Operation	4-1
4.2.1 Warming-up	4-1
4.2.2 Ready state (ready for copying)	4-2
4.2.3 Drawer feed copying with the [START] button	4-2
4.2.4 Bypass feed copying	4-6
4.2.5 Interruption copying	4-6
4.3 Detection of Abnormality	4-7
4.3.1 Types of abnormality	4-7
4.3.2 Description of abnormality	4-7
5. CONTROL PANEL	5-1
5.1 General Description	5-1
5.2 Items Shown on the Display Panel	5-2
5.2.1 Display	5-2
5.2.2 Message	5-3
5.3 Relation between the Equipment State and Operator's Operation	5-8
5.4 Description of Operation	5-10

5.4.1	Dot matrix LCD circuit	5-10
5.4.2	LED display circuit	5-11
5.5	Disassembly and Replacement.....	5-12
6.	SCANNING SECTION.....	6-1
6.1	Function	6-1
6.2	Construction	6-2
6.3	Operation	6-3
6.3.1	Scanner motor (M1).....	6-3
6.3.2	Two-phase motor drive circuit (fixed-current type)	6-4
6.4	Control for Exposure Lamp	6-5
6.4.1	General description.....	6-5
6.4.2	Exposure lamp.....	6-6
6.4.3	Control circuit for exposure lamp	6-7
6.5	CCD Control.....	6-8
6.5.1	Opto-electronic conversion	6-8
6.5.2	Shading correction.....	6-8
6.6	Automatic Original Size Detection Circuit	6-9
6.6.1	Principle of original size detection	6-9
6.6.2	Process of original size detection	6-9
6.7	Disassembly and Replacement.....	6-13
7.	LASER OPTICAL UNIT	7-1
7.1	General Description	7-1
7.2	Structure.....	7-4
7.2.1	Laser optical unit.....	7-4
7.2.2	Polygonal motor unit	7-6
7.2.3	f θ lenses 1 and 2.....	7-8
7.2.4	H-sync detection PC board (SNS board).....	7-8
7.2.5	Laser driving board (LDR1/LDR2 board).....	7-8
7.2.6	Slit glass	7-8
7.3	Laser Diode Control Circuit.....	7-9
7.4	Polygonal Motor Control Circuit	7-10
7.5	Laser Unit Cooling Fan Control Circuit.....	7-11
7.6	Disassembly and Replacement.....	7-12
8.	PAPER FEEDING SYSTEM.....	8-1
8.1	General Description	8-1
8.2	Functions.....	8-3
8.3	Operation	8-5
8.3.1	Operation of bypass pickup roller	8-5
8.3.2	Operation of drawer pickup roller.....	8-5
8.3.3	Paper separation	8-6
8.3.4	Driving.....	8-7
8.3.5	General operation	8-8
8.3.6	Description of Tandem LCF Operation	8-9
8.4	Tray-up motor control circuit	8-12
8.5	Feed motor control circuit.....	8-13
8.6	Transport motor control circuit	8-14
8.7	Registration motor control circuit.....	8-15
8.8	Tandem LCF tray-up motor / end fence motor.....	8-16
8.9	Disassembly and Replacement.....	8-17
9.	PROCESS RELATED SECTION	9-1
9.1	Construction	9-1
9.2	Functions.....	9-2
9.3	Charger Wire Cleaner Control Circuit	9-3
9.3.1	General description.....	9-3
9.3.2	Configuration	9-3
9.4	High-voltage Transformer Control Circuit.....	9-4

9.4.1	General description.....	9-4
9.4.2	Description of operation.....	9-5
9.5	Drum Surface Potential Sensor Control Circuit.....	9-6
9.5.1	General description.....	9-6
9.5.2	Configuration.....	9-6
9.5.3	Description of operation.....	9-7
9.6	Temperature/humidity detection circuit.....	9-8
9.6.1	Outline.....	9-8
9.6.2	Construction.....	9-8
9.7	Disassembly and Replacement.....	9-9
10.	DRUM/CLEANER UNIT	10-1
10.1	Construction.....	10-1
10.2	Functions.....	10-2
10.3	Drum Temperature Detection Circuit.....	10-3
10.4	Image Quality Control.....	10-4
10.4.1	Outline.....	10-4
10.4.2	Construction.....	10-4
10.4.3	Principle of Image Quality Sensor.....	10-5
10.4.4	Flow of control.....	10-5
10.5	Drum motor control circuit.....	10-6
10.6	Disassembly and Replacement.....	10-7
11.	DEVELOPER UNIT	11-1
11.1	Construction.....	11-1
11.2	Functions.....	11-2
11.3	Developer Unit Drive.....	11-6
11.4	Motor Control Circuit.....	11-7
11.4.1	New toner supply motor control circuit.....	11-7
11.4.2	Developer unit motor control circuit.....	11-8
11.5	Auto-toner Circuit.....	11-9
11.5.1	General description.....	11-9
11.5.2	Operation of auto-toner sensor.....	11-11
11.6	Disassembly and Replacement.....	11-12
12.	TRANSFER/TRANSPORT UNIT	12-1
12.1	General Description.....	12-1
12.2	Functions.....	12-2
12.3	General Description of Transfer Belt Unit Operation.....	12-3
12.4	Transfer belt motor control circuit.....	12-4
12.5	Disassembly and Replacement.....	12-5
13.	FUSER UNIT	13-1
13.1	Outline.....	13-1
13.2	Operation.....	13-1
13.3	Functions.....	13-2
13.4	Fuser Control Circuit.....	13-3
13.4.1	Configuration.....	13-3
13.4.2	Heating principle of IH coil.....	13-4
13.4.3	IH control circuit interface.....	13-5
13.4.4	Abnormality in the IH control circuit.....	13-5
13.4.5	Temperature detection section.....	13-7
13.5	Fuser Motor Control Circuit.....	13-13
13.6	Disassembly and Replacement.....	13-15
14.	EXIT/REVERSE SECTION.....	14-1
14.1	General Description.....	14-1
14.2	Functions.....	14-1
14.3	Driving of Exit/Reverse section.....	14-2
14.4	Operation.....	14-2
14.5	Exit motor control circuit.....	14-7

14.6	Reverse motor control circuit	14-8
14.7	Disassembly and Replacement.....	14-9
15.	REVERSING AUTOMATIC DOCUMENT FEEDER (RADF)	15-1
15.1	General Description	15-1
15.2	Functions.....	15-2
15.3	Description of Operation	15-3
15.3.1	Paper path	15-3
15.3.2	Drive	15-4
15.3.3	Original size detection	15-5
15.4	Electric Circuit Description	15-8
15.4.1	Signal block diagram	15-8
15.4.2	Electric circuit description	15-9
15.5	Disassembly and Replacement.....	15-14
15.5.1	RADF	15-14
15.5.2	RADF front cover	15-15
15.5.3	RADF rear cover	15-16
15.5.4	Original jam access cover.....	15-17
15.5.5	RADF left cover	15-18
15.5.6	Original tray	15-18
15.5.7	Original reverse tray	15-19
15.5.8	Platen sheet unit.....	15-19
15.5.9	RADF exit tray	15-20
15.5.10	Reading start guide unit.....	15-21
15.5.11	Exit guide / Exit/reverse guide / Reading end guide	15-22
15.5.12	Paper feeder unit	15-24
15.5.13	Pickup roller	15-25
15.5.14	Feed roller	15-26
15.5.15	Separation roller	15-27
15.5.16	Original registration roller.....	15-28
15.5.17	Intermediate transport roller.....	15-29
15.5.18	Reading start roller	15-30
15.5.19	Reading end roller	15-32
15.5.20	Exit roller.....	15-33
15.5.21	Exit/reverse roller.....	15-34
15.5.22	Exit intermediate roller	15-35
15.5.23	Reverse roller	15-36
15.5.24	Original feed motor (MR1)	15-38
15.5.25	Original feed motor bracket	15-38
15.5.26	Read motor (MR2)	15-39
15.5.27	Read motor bracket	15-40
15.5.28	Original reverse motor (MR3)	15-41
15.5.29	Original exit motor (MR4).....	15-41
15.5.30	RADF cooling fan (FR1)	15-42
15.5.31	Original pickup solenoid (SOLR1)	15-43
15.5.32	Original reverse solenoid (SOLR2).....	15-44
15.5.33	Original exit solenoid (SOLR3)	15-45
15.5.34	Original jam access cover opening/closing switch (SWR1).....	15-46
15.5.35	RADF opening/closing switch (SWR2)	15-46
15.5.36	RADF opening/closing sensor (SR15).....	15-48
15.5.37	Original empty sensor (SR3)	15-48
15.5.38	Original jam access cover opening/closing sensor (SR13)	15-49
15.5.39	Feeder lower guide unit	15-49
15.5.40	Original width detection sensor-3 (SR8).....	15-50
15.5.41	Original width detection sensor-2 (SR7).....	15-50
15.5.42	Original width detection sensor-1 (SR6).....	15-51
15.5.43	Original registration sensor (SR5)	15-51
15.5.44	Original exit sensor (SR12).....	15-51
15.5.45	Original tray sensor (SR1)	15-52

15.5.46	Original tray width sensor (SR2).....	15-53
15.5.47	Original exit/reverse sensor (SR11).....	15-54
15.5.48	Original reverse unit opening/closing sensor (SR14)	15-55
15.5.49	Original reading end sensor (SR4)	15-56
15.5.50	Original intermediate transport sensor (SR9)	15-56
15.5.51	Original reading start sensor (SR10)	15-56
15.5.52	Original reading start sensor (prism)	15-57
15.5.53	RADF board (RADF).....	15-58
15.5.54	RADF board bracket	15-58
15.5.55	Harness guide.....	15-59
16.	POWER SUPPLY UNIT	16-1
16.1	Construction	16-1
16.2	Operation of DC Output Circuit	16-2
16.3	Output Channel	16-4
16.4	Fuse	16-6
16.5	Configuration of Power Supply Unit	16-8
16.6	AC Wire Harness	16-9
17.	PC BOARDS	17-1
18.	EXTERNAL COUNTERS	18-1
18.1	Outline.....	18-1
18.2	Signal	18-1
18.3	Notices	18-4

1. SPECIFICATIONS/ACCESSORIES/OPTIONS/SUPPLIES

Notes:

Destinations (machine versions) of e-STUDIO555/655/755/855

- The machine versions are as follows:
 - NAD: North America / Central and South America
 - TWD: Taiwan
 - SAD: Saudi Arabia
 - ASD: Asia / Other
 - ARD: Argentina / Central and South America
 - AUD: Australia
 - MJD: Europe
 - CND: China
- The drawer configuration of each model differs depending on its destination (machine version).

Destination (Machine version)	e-STUDIO555	e-STUDIO655	e-STUDIO755	e-STUDIO855
NAD	Tandem LCF	Tandem LCF	Tandem LCF	Tandem LCF
TWD	-	Tandem LCF	Tandem LCF	Tandem LCF
SAD	Tandem LCF	Tandem LCF	Tandem LCF	Tandem LCF
ASD	Tandem LCF	Tandem LCF	Tandem LCF	Tandem LCF
ARD	Tandem LCF	Tandem LCF	Tandem LCF	Tandem LCF
AUD	Tandem LCF	Tandem LCF	Tandem LCF	Tandem LCF
MJD	Tandem LCF	Tandem LCF	Tandem LCF	Tandem LCF
CND	Tandem LCF	Tandem LCF	Tandem LCF	Tandem LCF

* Tandem LCF: This means 2 drawers and a tandem LCF.

1.1 Specifications

1.1.1 General

Type	Console	
Original glass	Fixed	
Copy process	Indirect electrophotographic process	
Developing system	2-component magnetic brush developing	
Fixing method	Heat roller system	
Photosensor type	OPC	
Original scanning sensor	Linear CCD sensor	
Scanning light source	Xenon lamp	
Resolution	Scanning	600 dpi × 600 dpi
	Writing	2400 dpi × 600 dpi
Gradation	256	
Paper feeding	2 drawers + Bypass feeding + Tandem LCF + LCF (optional)	

Paper supply	Drawers	Stack height 55 mm, equivalent to 500 sheets; 80 g/m ² (23 lb. Bond)
	Bypass feeding	Stack height 11 mm, equivalent to 100 sheets; 80 g/m ² (23 lb. Bond)
	LCF (optional)	Stack height 428 mm, equivalent to 4000 sheets; 80 g/m ² (23 lb. Bond)
	Tandem LCF	Stack height 137 mm, equivalent to 2500 sheets; 80 g/m ² (23 lb. Bond)
Paper size	Drawers	A3, A4, A4-R, A5-R, B4, B5, B5-R, FOLIO, 8K, 16K, 16K-R, LD, LG, LT, LT-R, ST-R, COMPUTER, 13"LG, 8.5" x 8.5"
	Bypass feeding	A3, A4, A4-R, A5-R, B4, B5, B5-R, FOLIO, 8K, 16K, 16K-R, LD, LG, LT, LT-R, ST-R, COMPUTER, 13"LG, 8.5" x 8.5" Non-standard: Width 100 - 297 mm (3.9 - 11.7"), Length 148 - 500 mm (5.8 - 19.7")
	LCF (optional)	A4, LT
	Tandem LCF	A4, LT
Paper type	Drawers	Plain paper, Thick 1, Thick 2, Thick 3, Tab paper* * The 2nd drawer is recommended to be used for tab paper.
	Bypass feeding	Plain paper, Thick 1, Thick 2, Thick 3, OHP film, Sticker labels, Tab paper
	LCF (optional)	Plain paper, Thick 1, Thick 2, Thick 3
	Tandem LCF	Plain paper, Thick 1, Thick 2, Thick 3
Paper weight	Drawers	64 g/m ² to 209 g/m ² (17 lb. Bond to 115.7 lb. Index)
	Bypass feeding	64 g/m ² to 209 g/m ² (17 lb. Bond to 115.7 lb. Index)
	LCF (optional)	64 g/m ² to 209 g/m ² (17 lb. Bond to 115.7 lb. Index)
	Tandem LCF	64 g/m ² to 209 g/m ² (17 lb. Bond to 115.7 lb. Index)
Automatic duplexing unit	Type	Stackless, Switchback type
	Acceptable paper size	A3, A4, A4-R, A5-R, B4, B5, B5-R, FOLIO, 8K, 16K, 16K-R, LD, LG, LT, LT-R, ST-R, COMPUTER, 13"LG, 8.5" x 8.5"
	Acceptable paper weight	64 g/m ² to 209 g/m ² (17 lb. Bond to 115.7 lb. Index)
Toner supply		Toner supplyAutomatic toner density detection/supply Toner cartridge replacing method (There is a recycle toner supplying mechanism.)
Toner density adjustment		Magnetic auto-toner system
Total counter		Electronical counter
Memory (RAM)	Main memory (Incl. page memory)	1 GB
HDD		60 GB
Account Codes		10,000 codes
Department Codes		1,000 codes
Warm-up time		Approx. 130 sec. (Stand-alone, temperature: 20 °C)

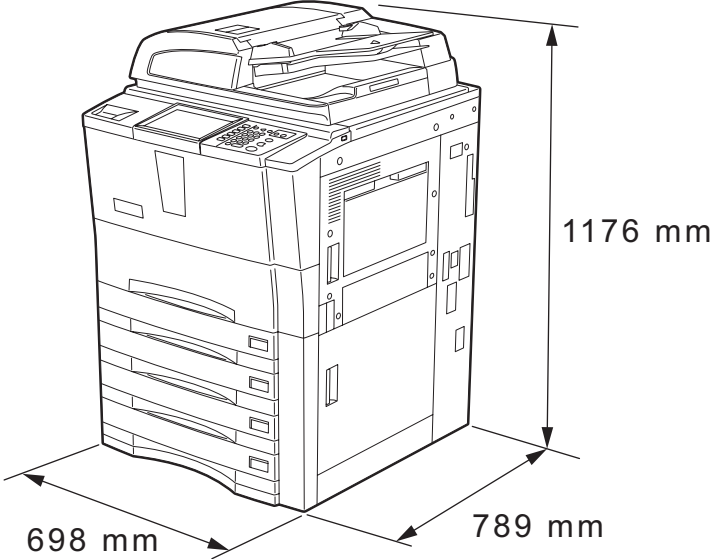
<p>Power requirements</p>	<p>AC 110 V / 16 A (50/60 Hz) AC 115 V / 16 A (50/60 Hz) AC 127 V / 16 A (50/60 Hz) AC 220 V / 9 A (50/60 Hz) AC 220-240 V / 9 A (50/60 Hz) * The acceptable value of each voltage is $\pm 10\%$.</p>
<p>Power consumption</p>	<p>2.0 kW or less * 1.5 kW or less: TWD version of e-STUDIO655. * The electric power is supplied to the Finisher, Inserter, Hole punch unit and LCF through the equipment</p>
<p>Dimensions of the equipment</p>	<p>W 698 x D 789 x H 1176 (mm)</p> 
<p>Weight</p>	<p>Approx. 202 kg (445 lb.) (equipment only)</p>

1.1.2 Copy

[1] Copy specifications

Storage capacity		Max. 2000 sheets or until the memory is full
Original glass	Original scanning system	Flat surface scanning system (the left rear corner used as guide to place originals)
	Original type	Sheets, books and 3-dimensional objects
	Original size	Max. A3/LD
Reversing Automatic Document Feeder	Original scanning system	Fixed scanning system by feeding the original (the center used as guide to place originals)
	Original type	Sheets (carbon, bounded or stapled originals cannot be accepted)
	Original size	A3, A4, A4-R, A5-R, B4, B5, B5-R LD, LG, LT, LT-R, ST-R
	Original paper weight	Single-sided copy: 35-209 g/m ² (9.3 lb. Bond -110 lb. Index)* Double-sided copy: 50-157 g/m ² (13.3 lb. Bond -40 lb. Bond)
	Original capacity	Max. 100 sheets (80 g/m ²) (Stack height 16 mm)
Eliminated portion		Leading edges: 3.0 (±2.0) mm, Trailing edges/Side edges: 2.0 (±2.0) mm,
Multiple copying		Up to 9999 copies; Key in set numbers
Density control		Automatic density mode and manual density mode selectable in 11 steps

[2] First copy time

e-STUDIO555/655	Approx. 4.0 sec.
e-STUDIO755/855	Approx. 3.5 sec.

[3] Copy speed (Copies/min.)

The measuring conditions of the copy speed are as follows.

- Continuous copying by placing a single-sided original on the original glass.
- “-” indicates “Not acceptable”.
- The LCF (optional) is available only for A4 and LT.
- The Tandem LCF is available only for A4 and LT.

[3-1] Plain paper

- Plain paper: 64 g/m² to 80 g/m² / 17 lb. Bond to 21.3 lb. Bond
- * Accuracy: Within ±2 sheets (Bypass feed) / Within ±1 sheet (Other paper sources)
- * Values may vary depending on its use condition and environment.
- * When the RADF is used, each copy speed per minute of e-STUDIO555/655/755/855 has reached 55/65/75/85 sheets. These copy speeds can be realized only in the following conditions.
 - Original: A4/LT / 1 sheet
 - Copy mode: A4/LT / Plain paper / Automatic Paper Selection - OFF / Automatic Copy Density - OFF
 - Number of copy set: 55 or more / 65 or more / 75 or more / 85 or more
 - Reproduction ratio: 100%

e-STUDIO555

Paper size	Paper supply	Drawer	Bypass feed		Option LCF	Tandem LCF
			Size specified	Size not specified		
A4, LT, B5	Top side discharging	55	45	28	55	55
	Back side discharging	55	45	28	55	55
A5-R, ST-R	Top side discharging	55	45	28	-	-
	Back side discharging	55	45	28	-	-
A4-R, B5-R, LT-R	Top side discharging	44	37	28	-	-
	Back side discharging	44	37	28	-	-
B4, LG, FOLIO, COMPUTER	Top side discharging	38	32	28	-	-
	Back side discharging	38	32	28	-	-
A3, LD	Top side discharging	34	28	28	-	-
	Back side discharging	32	28	28	-	-

e-STUDIO655

Paper size	Paper supply	Drawer	Bypass feed		Option LCF	Tandem LCF
			Size specified	Size not specified		
A4, LT, B5	Top side discharging	65	46	30	65	65
	Back side discharging	65	46	30	65	65
A5-R, ST-R	Top side discharging	65	46	30	-	-
	Back side discharging	65	46	30	-	-
A4-R, B5-R, LT-R	Top side discharging	48	38	30	-	-
	Back side discharging	48	38	30	-	-
B4, LG, FOLIO, COMPUTER	Top side discharging	42	34	30	-	-
	Back side discharging	40	34	30	-	-
A3, LD	Top side discharging	37	30	30	-	-
	Back side discharging	37	30	30	-	-

e-STUDIO755

Paper size	Paper supply	Drawer	Bypass feed		Option LCF	Tandem LCF
			Size specified	Size not specified		
A4, LT, B5	Top side discharging	75	46	30	75	75
	Back side discharging	75	46	30	75	75
A5-R, ST-R	Top side discharging	75	46	30	-	-
	Back side discharging	75	46	30	-	-
A4-R, B5-R, LT-R	Top side discharging	55	38	30	-	-
	Back side discharging	52	38	30	-	-
B4, LG, FOLIO, COMPUTER	Top side discharging	47	34	30	-	-
	Back side discharging	43	34	30	-	-
A3, LD	Top side discharging	40	30	30	-	-
	Back side discharging	35	30	30	-	-

e-STUDIO855

Paper size	Paper supply	Drawer	Bypass feed		Option LCF	Tandem LCF
			Size specified	Size not specified		
A4, LT, B5	Top side discharging	85	50	34	85	85
	Back side discharging	85	50	34	85	85
A5-R, ST-R	Top side discharging	85	50	34	-	-
	Back side discharging	85	50	34	-	-
A4-R, B5-R, LT-R	Top side discharging	61	42	34	-	-
	Back side discharging	56	42	34	-	-
B4, LG, FOLIO, COMPUTER	Top side discharging	52	38	34	-	-
	Back side discharging	45	38	34	-	-
A3, LD	Top side discharging	43	34	34	-	-
	Back side discharging	37	34	34	-	-

[3-2] Thick 1 / Thick 2

- Thick 1: 81 g/m² to 105 g/m² / 28 lb. Bond to 60 lb. Cover (90 lb. Index)
- Thick 2: 106 g/m² to 163 g/m² / 61 lb. Cover to 77.3 lb. Cover (115.7 lb. Index)

* Tolerance: Within -0.5 from +1

e-STUDIO555

Paper size	Paper supply	Drawer	Bypass feed		Option LCF	Tandem LCF
			Size specified	Size not specified		
A4, LT, B5	Top side discharging	55	45	28	55	55
	Back side discharging	55	45	-	55	55
A5-R, ST-R	Top side discharging	55	45	28	-	-
	Back side discharging	55	45	-	-	-
A4-R, B5-R, LT-R	Top side discharging	44	37	28	-	-
	Back side discharging	44	37	-	-	-
B4, LG, FOLIO, COMPUTER	Top side discharging	38	32	28	-	-
	Back side discharging	38	32	-	-	-
A3, LD	Top side discharging	34	28	28	-	-
	Back side discharging	32	28	-	-	-

e-STUDIO655

Paper size	Paper supply	Drawer	Bypass feed		Option LCF	Tandem LCF
			Size specified	Size not specified		
A4, LT, B5	Top side discharging	65	46	30	65	65
	Back side discharging	65	46	-	65	65
A5-R, ST-R	Top side discharging	65	46	30	-	-
	Back side discharging	65	46	-	-	-
A4-R, B5-R, LT-R	Top side discharging	48	38	30	-	-
	Back side discharging	48	38	-	-	-
B4, LG, FOLIO, COMPUTER	Top side discharging	42	34	30	-	-
	Back side discharging	40	34	-	-	-
A3, LD	Top side discharging	37	30	30	-	-
	Back side discharging	33	30	-	-	-

e-STUDIO755

Paper size	Paper supply	Drawer	Bypass feed		Option LCF	Tandem LCF
			Size specified	Size not specified		
A4, LT, B5	Top side discharging	75	46	30	75	75
	Back side discharging	75	46	-	75	75
A5-R, ST-R	Top side discharging	75	46	30	-	-
	Back side discharging	75	46	-	-	-
A4-R, B5-R, LT-R	Top side discharging	55	38	30	-	-
	Back side discharging	52	38	-	-	-
B4, LG, FOLIO, COMPUTER	Top side discharging	47	34	30	-	-
	Back side discharging	43	34	-	-	-
A3, LD	Top side discharging	40	30	30	-	-
	Back side discharging	35	30	-	-	-

e-STUDIO855

Paper size	Paper supply	Drawer	Bypass feed		Option LCF	Tandem LCF
			Size specified	Size not specified		
A4, LT, B5	Top side discharging	85	50	34	85	85
	Back side discharging	85	50	-	85	85
A5-R, ST-R	Top side discharging	85	50	34	-	-
	Back side discharging	85	50	-	-	-
A4-R, B5-R, LT-R	Top side discharging	61	42	34	-	-
	Back side discharging	56	42	-	-	-
B4, LG, FOLIO, COMPUTER	Top side discharging	52	38	34	-	-
	Back side discharging	45	38	-	-	-
A3, LD	Top side discharging	43	34	34	-	-
	Back side discharging	37	34	-	-	-

[3-3] Thick 3

- Thick 3: 210 g/m² to 256 g/m² / 77.3 lb. Cover to 94.5 lb. Cover (141.4 lb. Index)

* Tolerance: Within -0.5 from +1

e-STUDIO555

Paper size	Paper supply	Drawer	Bypass feed		Option LCF	Tandem LCF
			Size specified	Size not specified		
A4, LT, B5	Top side discharging	52	45	28	52	52
	Back side discharging	52	45	-	52	52
A5-R, ST-R	Top side discharging	52	45	28	-	-
	Back side discharging	52	45	-	-	-
A4-R, B5-R, LT-R	Top side discharging	42	37	28	-	-
	Back side discharging	42	37	-	-	-
B4, LG, FOLIO, COMPUTER	Top side discharging	37	32	28	-	-
	Back side discharging	37	32	-	-	-
A3, LD	Top side discharging	33	28	28	-	-
	Back side discharging	31	28	-	-	-

e-STUDIO655

Paper size	Paper supply	Drawer	Bypass feed		Option LCF	Tandem LCF
			Size specified	Size not specified		
A4, LT, B5	Top side discharging	60	46	30	60	60
	Back side discharging	60	46	-	60	60
A5-R, ST-R	Top side discharging	60	46	30	-	-
	Back side discharging	60	46	-	-	-
A4-R, B5-R, LT-R	Top side discharging	46	38	30	-	-
	Back side discharging	46	38	-	-	-
B4, LG, FOLIO, COMPUTER	Top side discharging	41	34	30	-	-
	Back side discharging	38	34	-	-	-
A3, LD	Top side discharging	36	30	30	-	-
	Back side discharging	32	30	-	-	-

e-STUDIO755

Paper size	Paper supply	Drawer	Bypass feed		Option LCF	Tandem LCF
			Size specified	Size not specified		
A4, LT, B5	Top side discharging	65	46	30	65	65
	Back side discharging	65	46	-	65	65
A5-R, ST-R	Top side discharging	65	46	30	-	-
	Back side discharging	65	46	-	-	-
A4-R, B5-R, LT-R	Top side discharging	50	38	30	-	-
	Back side discharging	48	38	-	-	-
B4, LG, FOLIO, COMPUTER	Top side discharging	43	34	30	-	-
	Back side discharging	40	34	-	-	-
A3, LD	Top side discharging	37	30	30	-	-
	Back side discharging	34	30	-	-	-

e-STUDIO855

Paper size	Paper supply	Drawer	Bypass feed		Option LCF	Tandem LCF
			Size specified	Size not specified		
A4, LT, B5	Top side discharging	72	46	30	72	72
	Back side discharging	72	46	-	72	72
A5-R, ST-R	Top side discharging	72	46	30	-	-
	Back side discharging	72	46	-	-	-
A4-R, B5-R, LT-R	Top side discharging	52	38	30	-	-
	Back side discharging	50	38	-	-	-
B4, LG, FOLIO, COMPUTER	Top side discharging	44	34	30	-	-
	Back side discharging	41	34	-	-	-
A3, LD	Top side discharging	37	30	30	-	-
	Back side discharging	34	30	-	-	-

[4] System copy speed

Model	Copy mode	A4 (%)			
		1 sheet	5 sheets	10 sheets	20 sheets
e-STUDIO555	Single-sided originals ↓ Single-sided copies	74	89	94	96
	Single-sided originals ↓ Double-sided copies	53	82	89	93
	Double-sided originals ↓ Double-sided copies	61	87	92	95
	Double-sided originals ↓ Single-sided copies	68	92	95	97
e-STUDIO655	Single-sided originals ↓ Single-sided copies	72	88	93	96
	Single-sided originals ↓ Double-sided copies	49	79	87	93
	Double-sided originals ↓ Double-sided copies	52	82	89	94
	Double-sided originals ↓ Single-sided copies	58	87	92	95
e-STUDIO755	Single-sided originals ↓ Single-sided copies	66	87	93	96
	Single-sided originals ↓ Double-sided copies	47	77	86	93
	Double-sided originals ↓ Double-sided copies	46	78	87	93
	Double-sided originals ↓ Single-sided copies	51	83	90	94
e-STUDIO855	Single-sided originals ↓ Single-sided copies	58	84	90	94
	Single-sided originals ↓ Double-sided copies	43	74	86	93
	Double-sided originals ↓ Double-sided copies	42	76	85	91
	Double-sided originals ↓ Single-sided copies	45	81	88	93

* Shows the period of time from when the [START] button is pressed until the message "Ready" is displayed. (10 sheets of A4/LT size original are set on the RADF and one of the copy modes above is selected.)

* Setting: when in the Text/Photo mode with Automatic density and APS/AMS set to OFF, or when in the sort mode with paper fed from the 1st drawer.

* The Finisher, Hole punch unit and Inserter are not installed.

1.1.3 Print

Page Description Language		PCL6 emulation (PCL), PostScript 3 emulation (PS), XPS
Supported Client OS		Windows 2000 / XP / Server 2003 / Vista / Server 2008, Mac OS X (Ver.10.2 or higher) Solaris (SUN) / HP-UX / AIX (IBM) / Linux / SCO
Resolution		600 x 600 dpi
Eliminated portion		Leading edges / Trailing edges / Side edges: 4.2 (±2.0) mm
Interface	Standard	USB 2.0 (High Speed), Ethernet (10BASE-T/100BASE-TX)
	Optional	Wireless LAN (IEEE 802.11b/g), Bluetooth

1.1.4 Scan

Scanning speed	66 sheets/min
Resolution	600 x 600 dpi
Original mode	[TEXT], [TEXT/PHOTO], [PHOTO], [Gray scale]
File formats	JPEG (Gray scale mode only), Multi/Single page TIFF, Multi/Single page PDF, Multi/Single page XPS

* Measuring condition of the scanning speed: Scanning single-sided A4/LT originals in the Text/Photo mode with 100% reproduction ratio using the RADF

1.1.5 e-Filing

Number of Boxes	Public Box	1
	User Box	200
Number of Folder		100 folders per box
Number of Document		400 documents per box/folder
Number of Page		200 pages per document
Capacity of HDD	e-Filing	7 GB

1.1.6 Internet Fax

[1] Internet FAX transmission

Resolution	TX Resolution < dots/mm >	Standard (8 x 3.85), Fine (8 x 7.7), U-Fine (16 x 15.4)* * If U-Fine is selected in TX resolution, data is converted to Fine resolution in RX.
Scanning	Original Document Size	A3, B4, A4, A4-R, A5, B5, B5-R, A5-R, LT, LT-R, LG, LD, ST, ST-R, Computer, Folio
	Speed	0.7sec. (per page/A4) Max.50 spm (ITU-T No.1, A4, 8 x 3.85,Text mode)
	Gray scale	256 levels (Error Diffusion)
Address book	Address Book	1000 stations
	Group	Max. 200 stations
Transmission Features	Broadcast transmission	Max. 400 destinations/job. (Fax number and E-mail address are available to registered in same job.)
	Message size limitation	Max. 30M Byte
	Message division	Page by page

[2] Internet FAX receiving

Format of receive attachment	TIFF-FX (Profile S, F, J)
------------------------------	---------------------------

1.1.7 Network Fax

Compatibility		Super G3, G3 (ITU-T.30) Internet Fax (Simple mode) (ITU-T.37)
TX Resolution	PSTN	Standard: 200 x 100 dpi, Fine: 200 x 200 dpi, Super Fine: 200 x 400 dpi, Ultra Fine: 400 x 400 dpi
	Internet Fax	200 dpi x 200 dpi
Original Document Size		A3, B4, A4, B5, A5, LT, LG, LD, ST, Folio, Computer
Mail Box	User defined	Max. 300 boxes
Routed document format	Send to e-Filing	MMR
	Send to File (SMB)	Single TIFF, Multi-TIFF, Single PDF, Multi PDF
	Send to FTP	Single TIFF, Multi-TIFF, Single PDF, Multi PDF
	Send to E-mail	Single TIFF, Multi-TIFF, Single PDF, Multi PDF
	Send to I-Fax	TIFF-S
	Send to PSTN-FAX	MMR

1.2 Accessories

Unpacking/setup instruction	1 pc.
CD-ROM	1 pc.
Drum	1 pc.
Toner bag (Installed inside of the equipment)	1 pc.
Operator's manual pocket	1 pc.
Original feeding tray spacer	1 pc.
Tab paper end guide	1 pc.
Cleaning cloth	1 pc.
Cloth case	1 pc.
Power cable	1 pc. (for TWD (e-STUDIO655), ASD, ARD, AUD, MJD, CND)
Setup report	1 set (for NAD, MJD, CND)
Approval sheet	1 pc. (for CND)
Envelope	1 pc. (for CND)
Packing list	1 pc. (for CND)
Developer material	1 pc. (for CND)
Toner bottle	1 pc. (for CND)

1.3 Options

Large Capacity Feeder (LCF)	MP-4004L/A
Finisher	MJ-1027
Saddle stitch finisher	MJ-1028
Saddle stitch finisher (100 sheets stapling)	MJ-1029
Staple cartridge	STAPLE-700 (for MJ-1027/1028) STAPLE-1700 (for MJ-1029) STAPLE-1800 (for MJ-1029) STAPLE-1900 (for MJ-1029) STAPLE-600 (for saddle stitch)
Finisher guide rail	KN-1017
Hole punch unit	MJ-6003N/E/F/S
Insertor	MJ-7001
Damp heater kit	MF-6000U/E
Fax unit	GD-1250NA/EU/AU/AS/C
2nd line for Fax unit	GD-1260NA/EU-N/AU/C
Printer kit	GM-1180
Printer/Scanner kit	GM-2180
Scanner kit	GM-4180
Wireless LAN module	GN-1050
Bluetooth module	GN-2010
Antenna	GN-3010
Data overwrite enabler	GP-1070
e-BRIDGE ID Gate (HID iClass)	KP-2004
e-BRIDGE ID Gate (MIFARE)	KP-2005
Meta scan enabler	GS-1010
External interface enabler	GS-1020
IPsec enabler	GP-1080
Harness kit	GQ-1240 (for coin controller) GQ-1050 (for card controller) GQ-1060 (for card controller)

- * The finisher (MJ-1027/1028) is necessary for the installation of the hole punch unit (MJ-6003N/E/F/S) and the insertor (MJ-7001).
- * The Printer kit (GM-1180), Printer/Scanner kit (GM-2180) and Scanner kit (GM-4180) are optional for TWD/SAD/ASD/AUD model.
- * The antenna (GN-3010) is necessary to enable the wireless LAN module (GN-1050) and the bluetooth module (GN-2010).
- * Up to 2 antennas (GN-3010) can be connected to the wireless LAN module (GN-1050).
- * When the wireless LAN module (GN-1050) and the bluetooth module (GN-2010) are installed together, only 1 antenna (GN-3010) can be connected to each.
- * STAPLE-1700 (100 sheets stapling): 3 cases of 5000 staples in a package
STAPLE-1800 (50 sheets stapling): 3 cases of 5000 staples and one exclusive cartridge in a package
STAPLE-1900 (50 sheets stapling): 3 cases of 5000 staples in a package

1.4 Supplies

Drum	OD-6510
Developer	D-6000
Toner cartridge	PS-ZT8550 (for NAD, ARD) PS-ZT8550E (for MJD) PS-ZT6000C (for CND) PS-ZT6000D (for other)
Toner bag	PS-TB6510E (for MJD,.) PS-TB6510 (for other)

1.5 System List

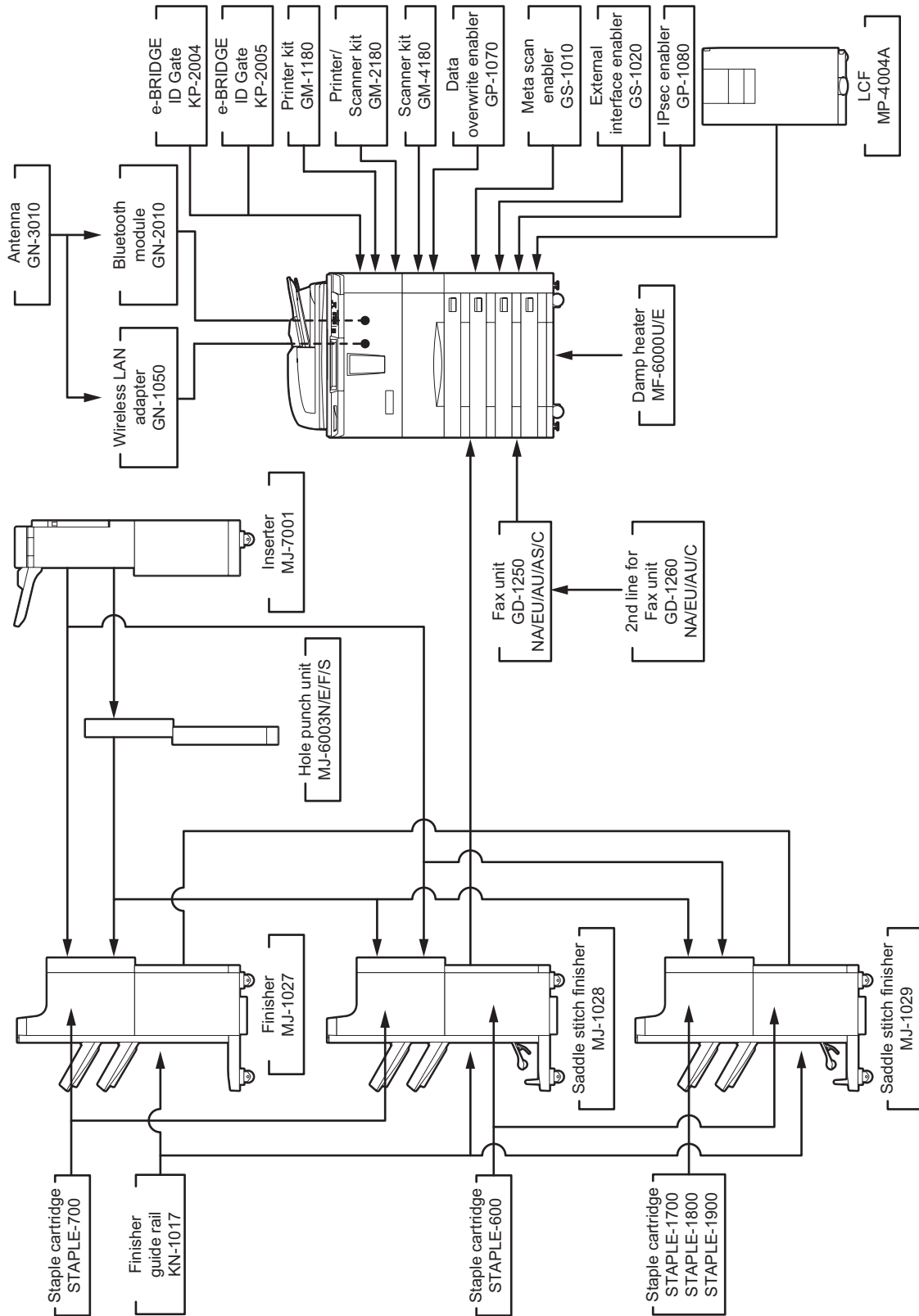

Fig. 1-1

2. OUTLINE OF THE MACHINE

2.1 Sectional View

2.1.1 Front view

4 drawers model

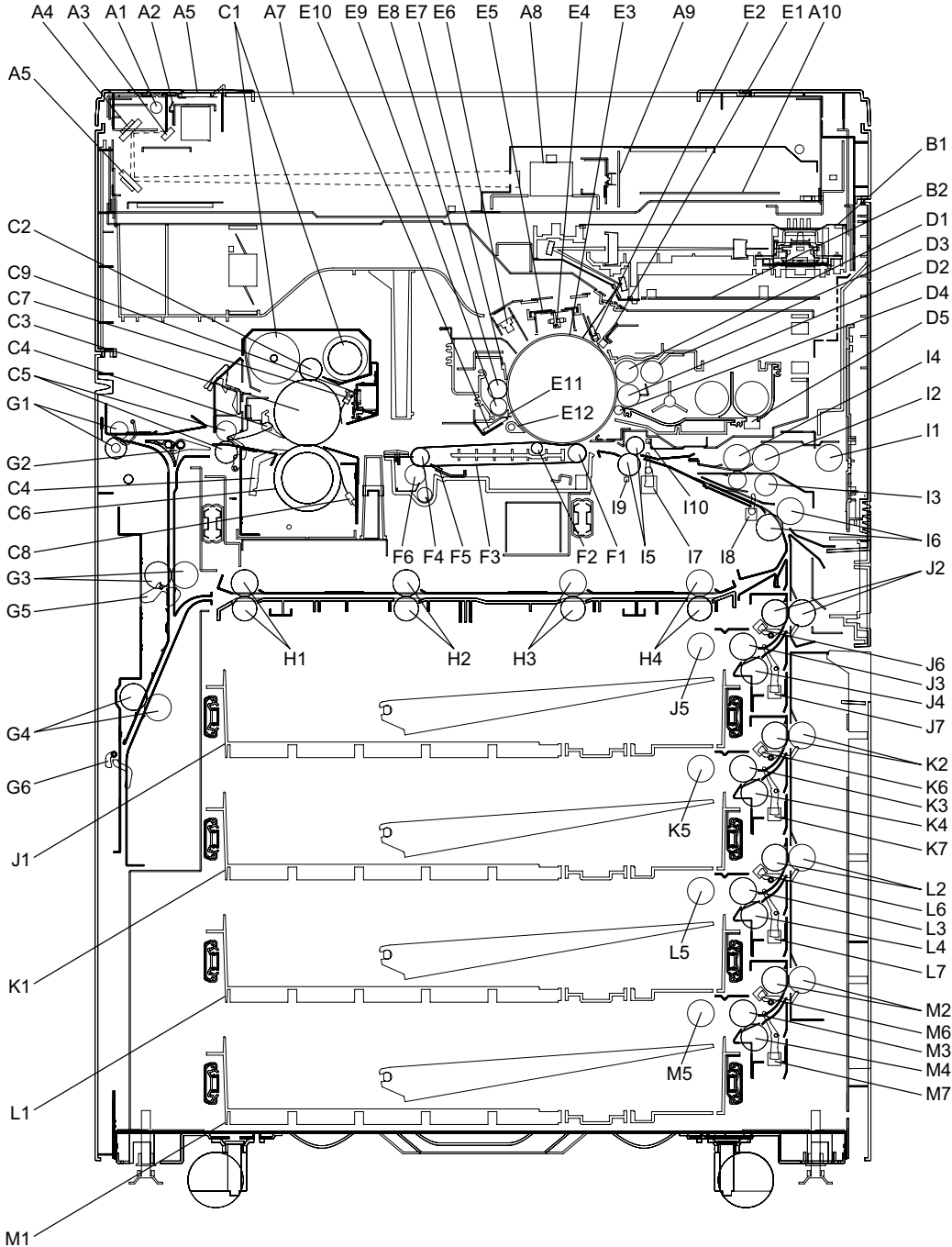

Fig. 2-1

2 drawers and tandem LCF model

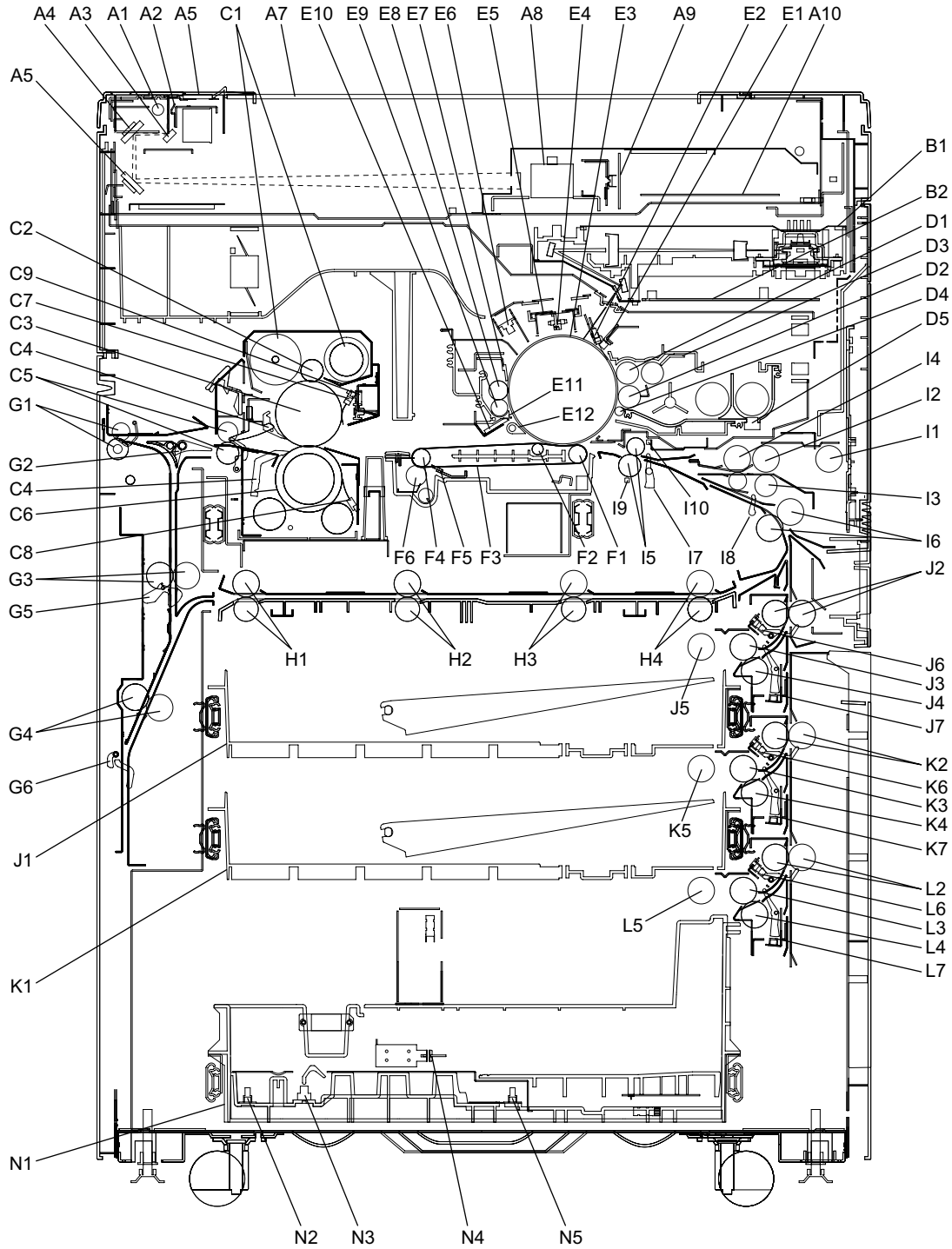

Fig. 2-2

A1	Exposure lamp	G5	Reverse sensor-1
A2	Reflector	G6	Reverse sensor-2
A3	Mirror-1	H1	Horizontal transport roller-1
A4	Mirror-2	H2	Horizontal transport roller-2
A5	Mirror-3	H3	Horizontal transport roller-3
A6	ADF original glass	H4	Horizontal transport roller-4
A7	Original glass	I1	Bypass pickup roller
A8	Lens	I2	Bypass feed roller
A9	CCD driving PC board (CCD board)	I3	Bypass separation roller
A10	Scanning section control PC board (SLG board)	I4	Bypass transport roller
B1	Laser optical unit	I5	Registration roller
B2	Laser control PC board (PLG board)	I6	Intermediate transfer roller
C1	Cleaning web	I7	Registration sensor
C2	Cleaning web pushing roller	I8	Intermediate transport sensor
C3	Fuser roller	I9	Paper dust removal brush-1
C4	Separation finger	I10	Paper dust removal brush-2
C5	Fuser exit roller	J1	1st drawer
C6	Pressure roller	J2	1st drawer transport roller
C7	Fuser roller thermistor	J3	1st drawer feed roller
C8	Pressure roller thermistor	J4	1st drawer separation roller
C9	Fuser roller thermostat	J5	1st drawer pickup roller
D1	Upper developer sleeve (Magnetic roller)	J6	1st drawer transport sensor
D2	Lower developer sleeve (Magnetic roller)	J7	1st drawer feed sensor
D3	Doctor blade	K1	2nd drawer
D4	Scattered toner recovery roller	K2	2nd drawer transport roller
D5	Auto-toner sensor	K3	2nd drawer feed roller
E1	Drum surface potential sensor	K4	2nd drawer separation roller
E2	Drum thermistor	K5	2nd drawer pickup roller
E3	Drum	K6	2nd drawer transport sensor
E4	Charger wire cleaner	K7	2nd drawer feed sensor
E5	Main charger	L1	3rd drawer
E6	Discharge LED	L2	3rd drawer transport roller / Tandem LCF transport roller
E7	Drum cleaning blade	L3	3rd drawer feed roller / Tandem LCF feed roller
E8	Drum cleaning brush	L4	3rd drawer separation roller / Tandem LCF separation roller
E9	Recovered toner transport auger	L5	3rd drawer pickup roller / Tandem LCF pickup roller
E10	Image quality sensor	L6	3rd drawer transport sensor
E11	Drum recovery blade	L7	3rd drawer feed sensor
E15	Drum separation finger	M1	4th drawer
F1	Transfer belt driven roller	M2	4th drawer transport roller
F2	Transfer belt power supply roller	M3	4th drawer feed roller
F3	Transfer belt	M4	4th drawer separation roller
F4	Transfer belt drive roller	M5	4th drawer pickup roller
F5	Transfer belt cleaning blade	M6	4th drawer transport sensor
F6	Transfer belt cleaning brush	M7	4th drawer feed sensor
G1	Exit roller	N1	Tandem LCF
G2	Reverse/exit switching gate	N2	End fence home position sensor
G3	Reverse path roller-1	N3	Standby side empty sensor
G4	Reverse path roller-2	N4	Standby side mis-stacking sensor
		N5	End fence stop position sensor

2.1.2 Rear view

4 drawers model

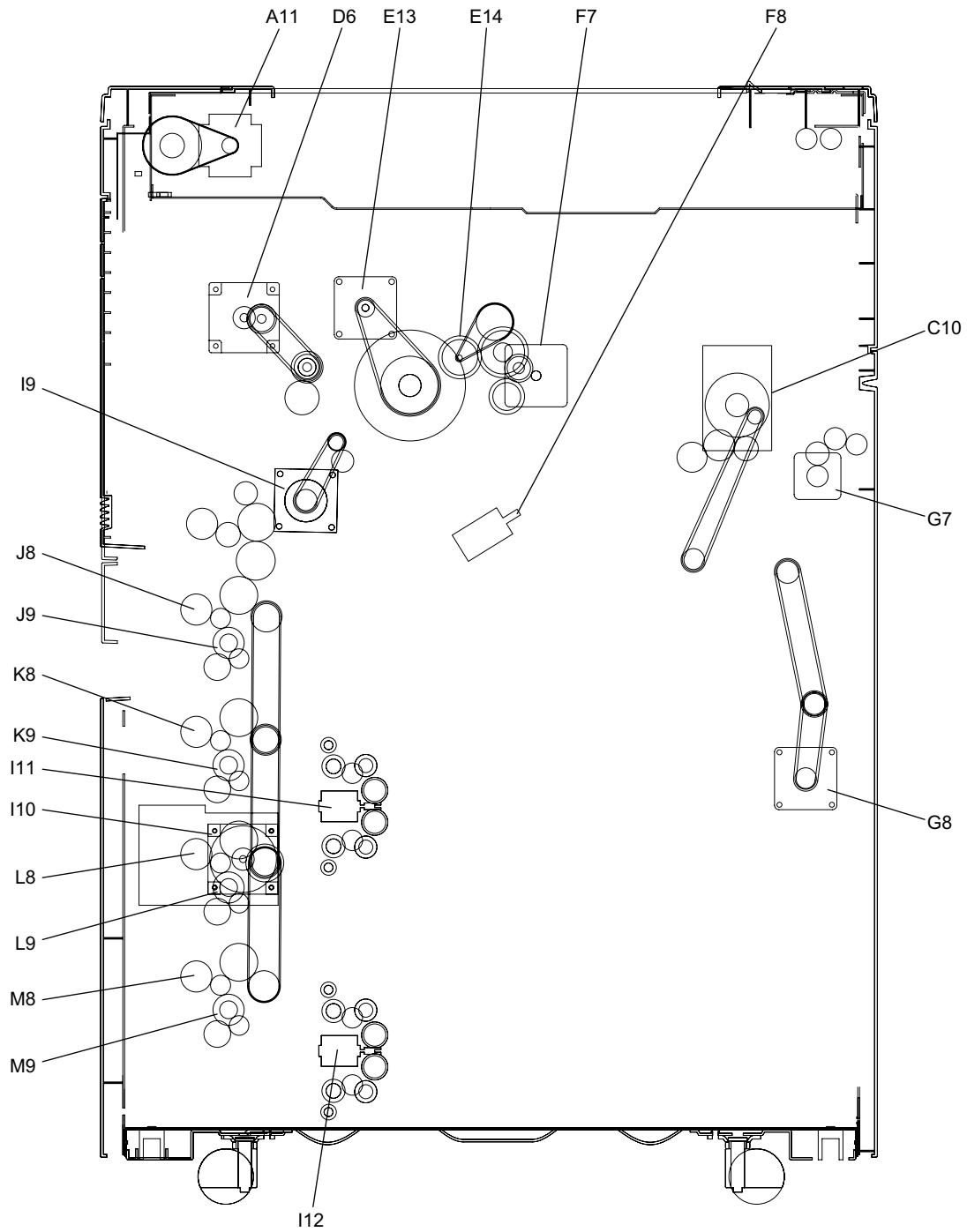

Fig. 2-3

2 drawers and tandem LCF model

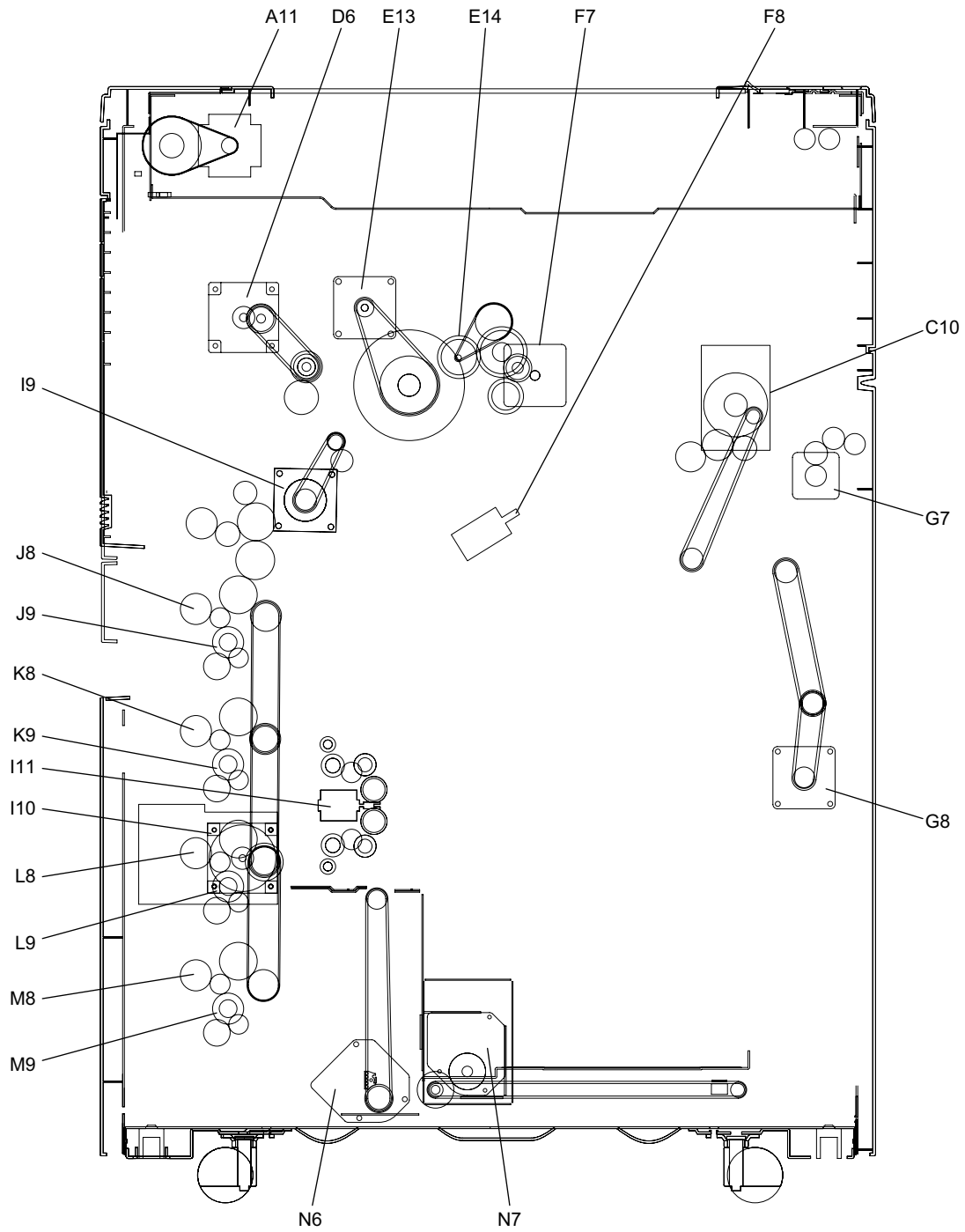

Fig. 2-4

A11	Scan motor
C10	Fuser motor
D6	Developer unit motor
E13	Drum motor
E14	Cleaning brush drive motor
F7	Transfer belt motor
F8	Transfer belt cam motor
G7	Exit motor
G8	Reverse motor
I9	Registration motor
I10	Feed motor
I11	Tray-up motor-1
I12	Tray-up motor-2
J8	1st drawer transport clutch
J9	1st drawer feed clutch
K8	2nd drawer transport clutch
K9	2nd drawer feed clutch
L8	3rd drawer transport clutch
L9	3rd drawer feed clutch
M8	4th drawer transport clutch
M9	4th drawer feed clutch
N6	Tandem LCF tray-up motor
N7	Tandem LCF end fence motor

2.2 Electric Parts Layout

[A] Scanner unit

a. A4 series

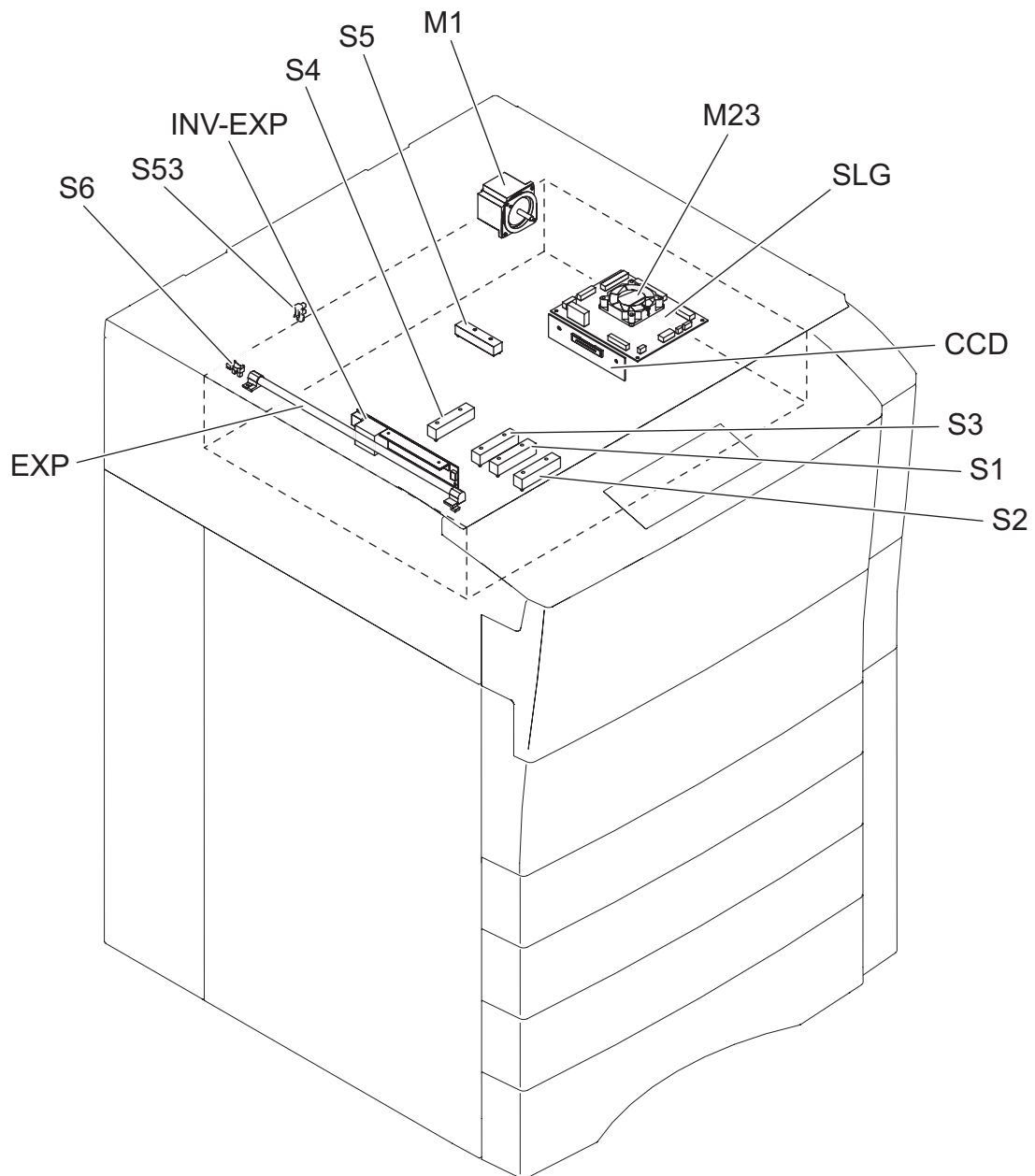

Fig. 2-5

b. LT series

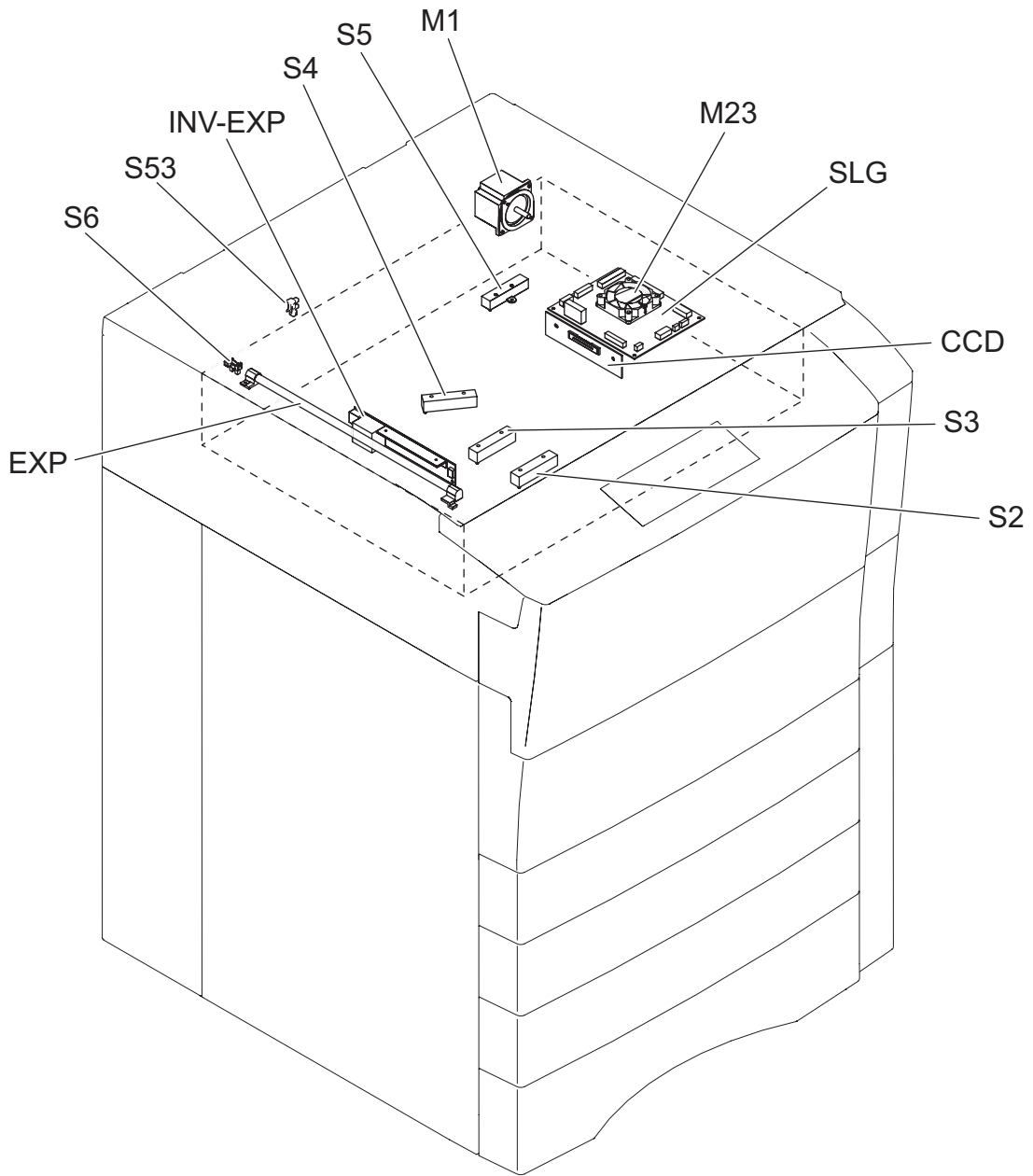

Fig. 2-6

c. Heater, thermostat

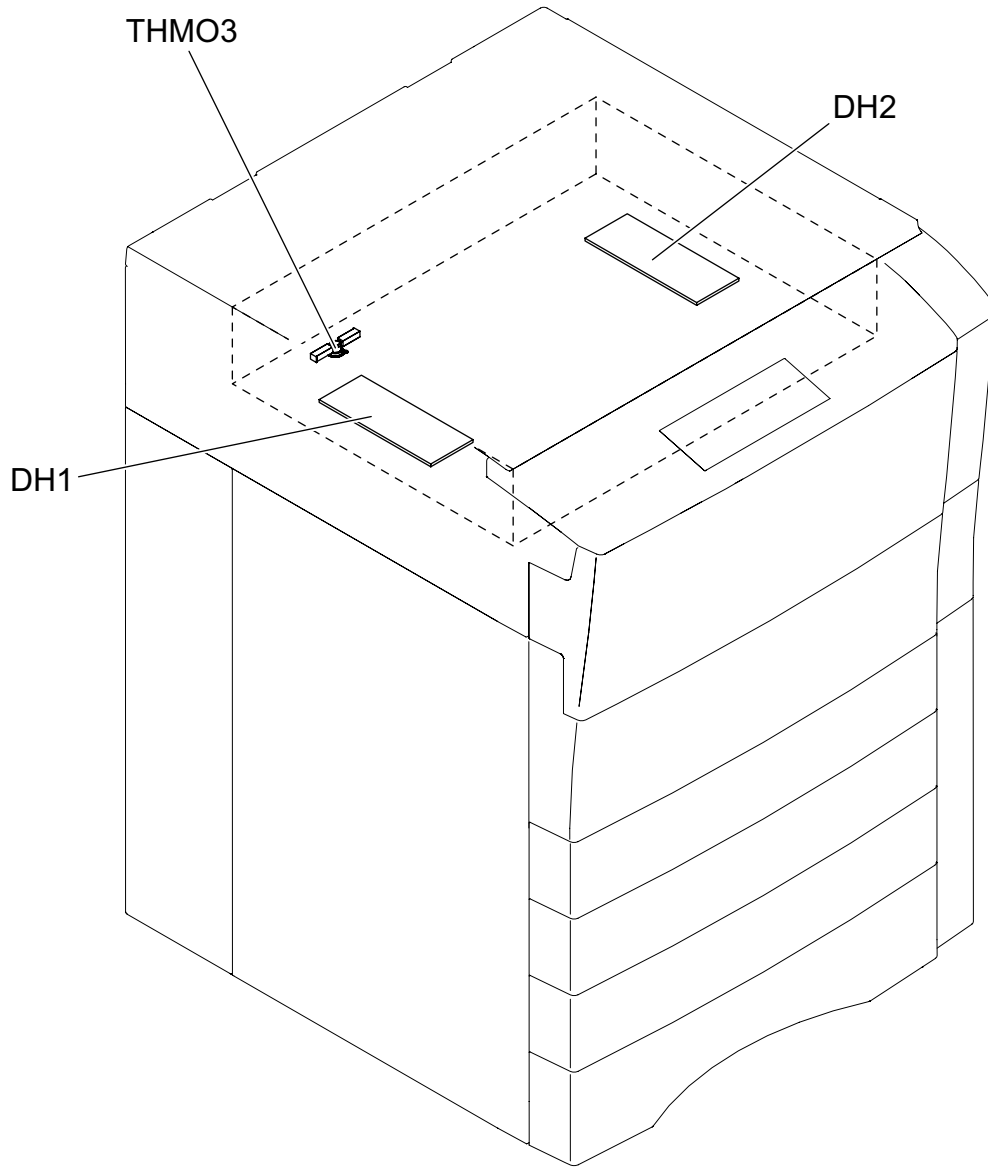

Fig. 2-7

[B] Control panel

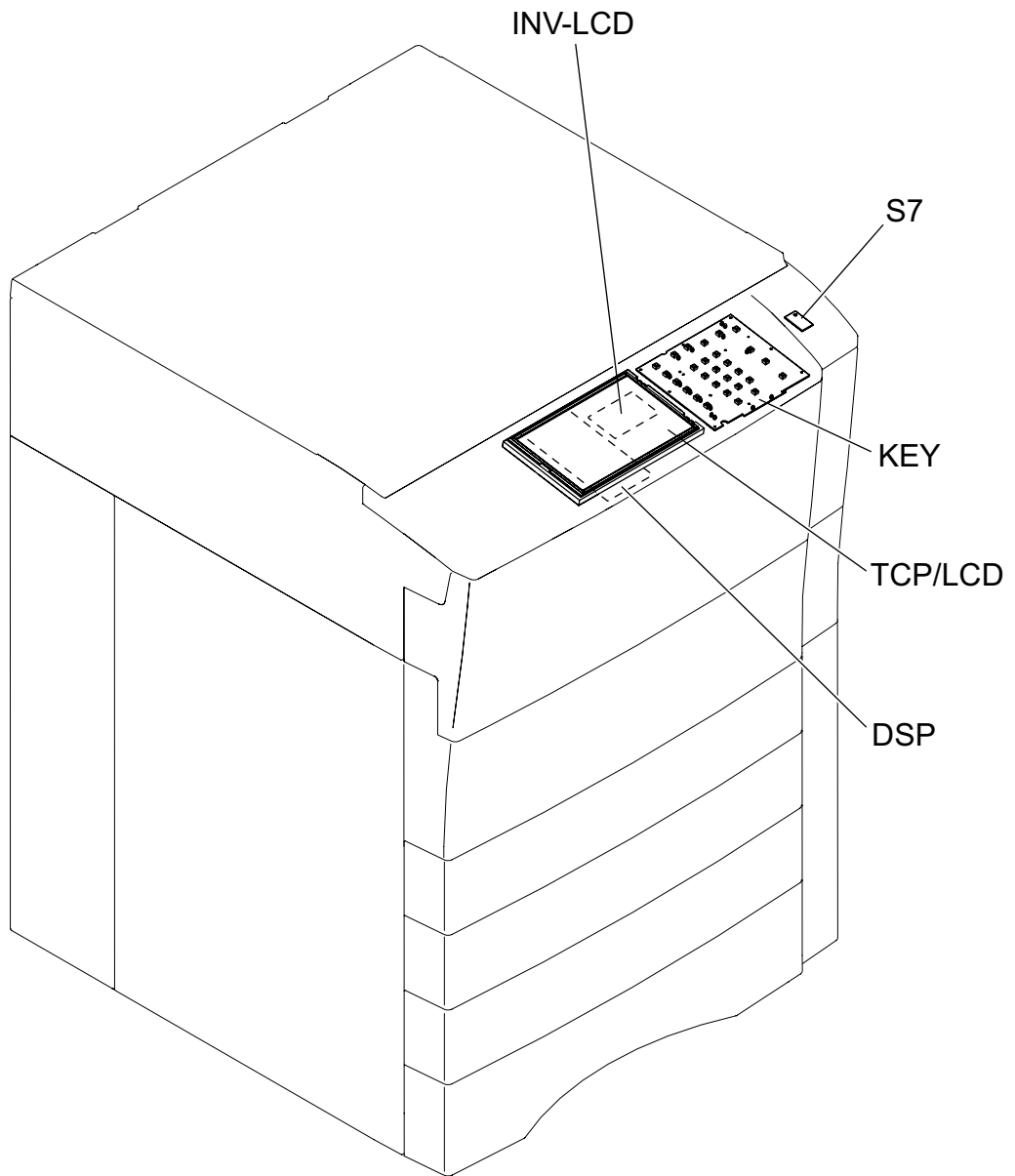

Fig. 2-8

[C] Laser unit
a. e-STUDIO555/655

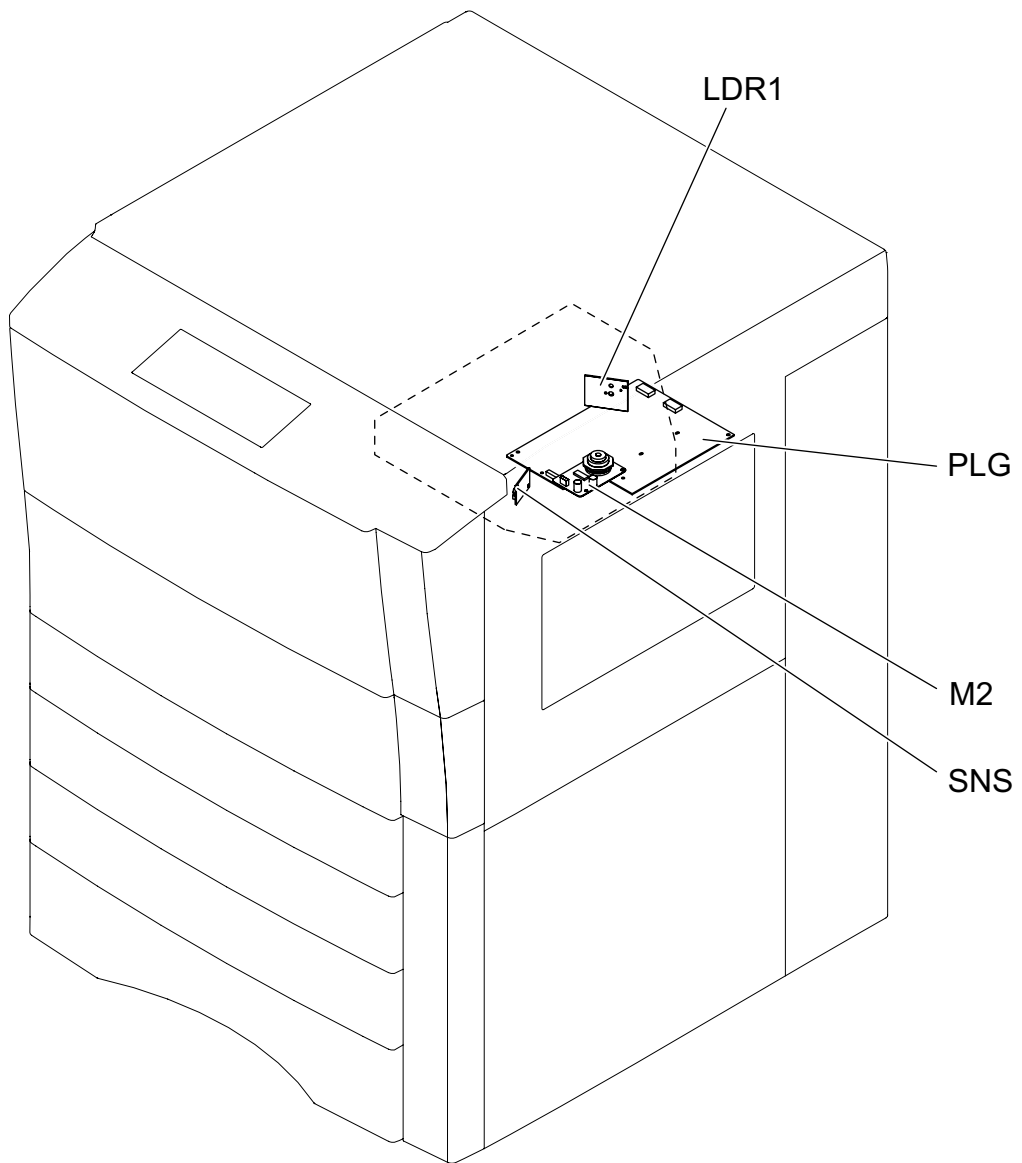

Fig. 2-9

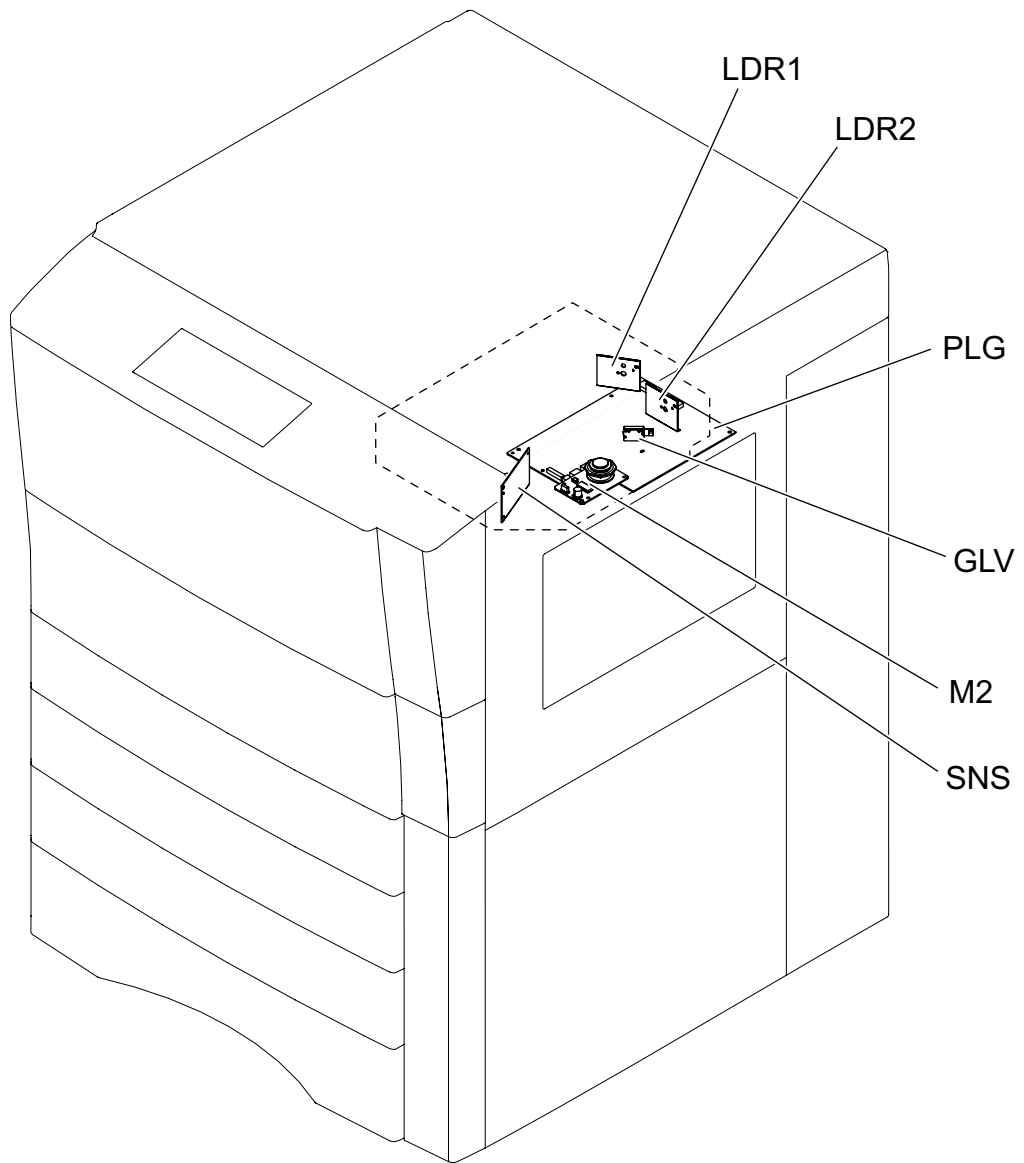

Fig. 2-10

[D] Fuser related section

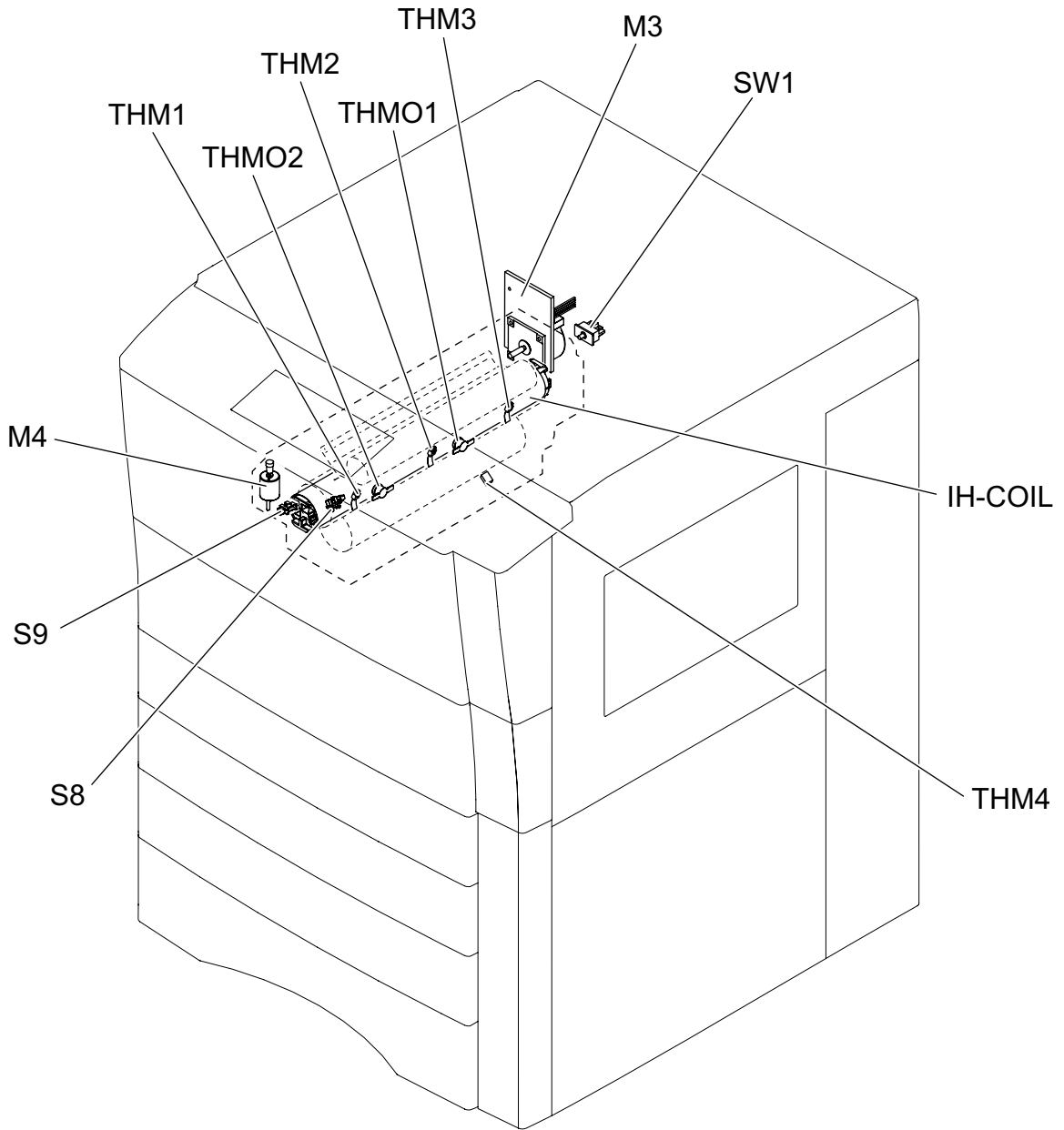

Fig. 2-11

[E] Toner cartridge related section

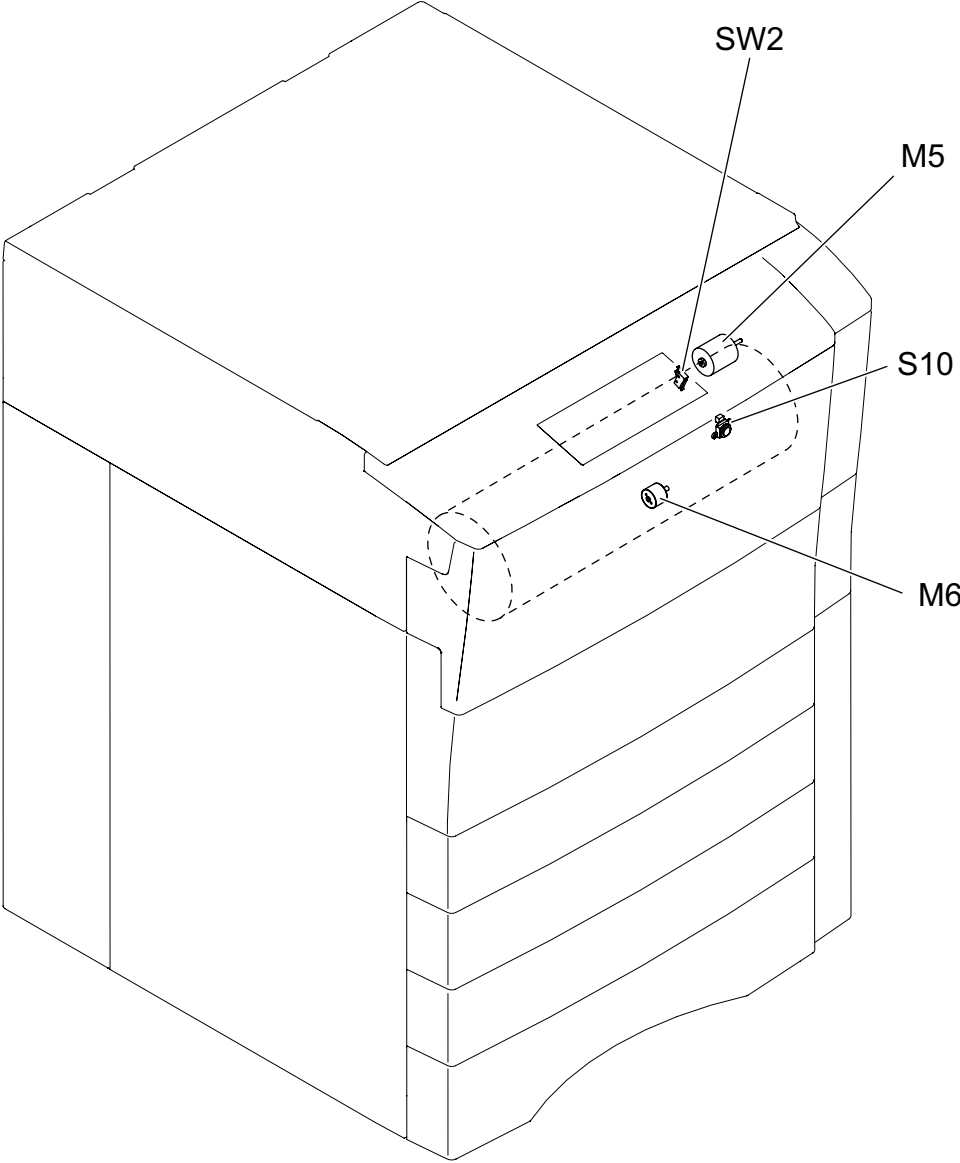

Fig. 2-12

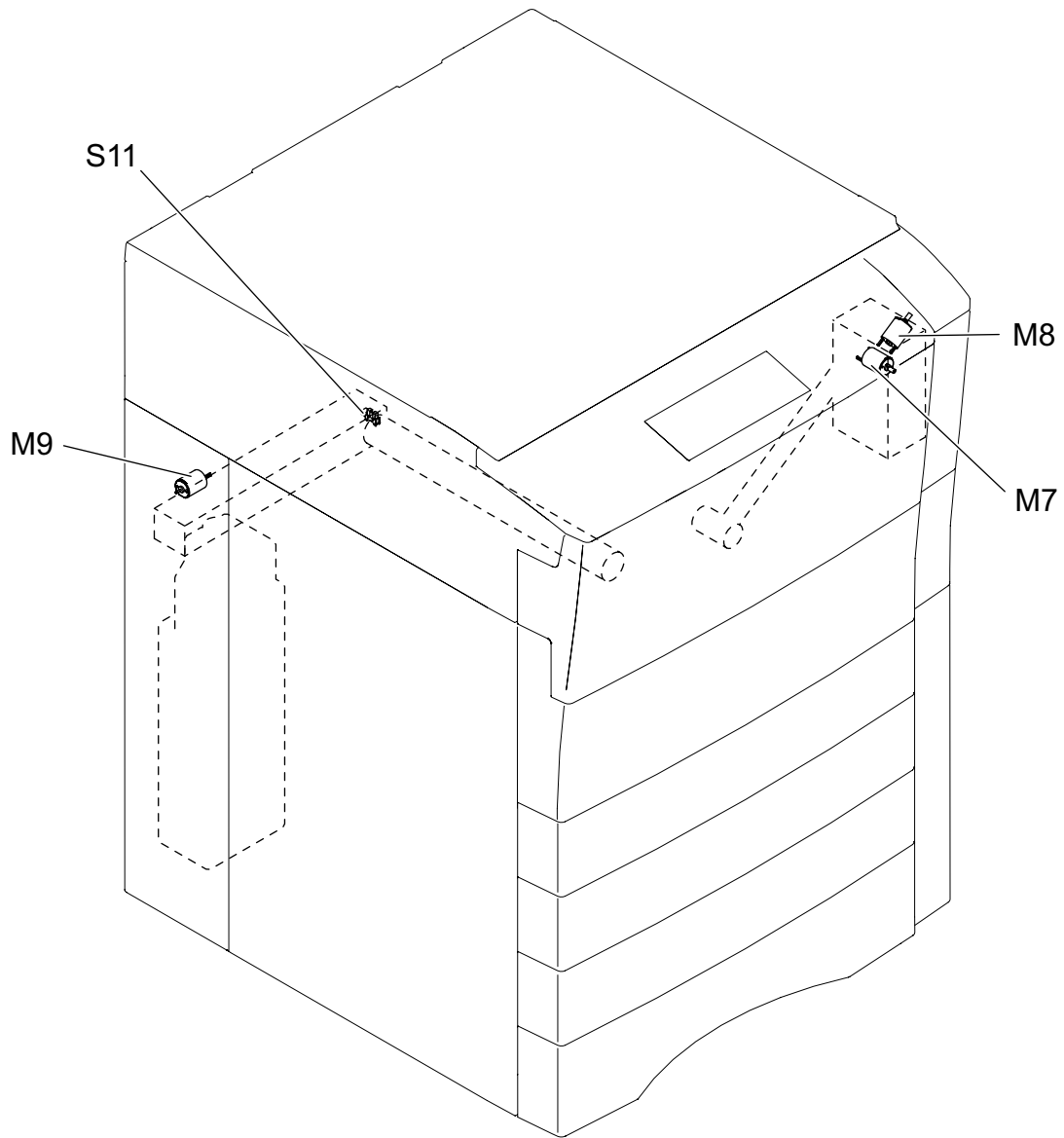

Fig. 2-13

[G] Developer unit / drum / transfer belt unit related section

a. Motor, sensor, switch, solenoid, lamp, thermistor

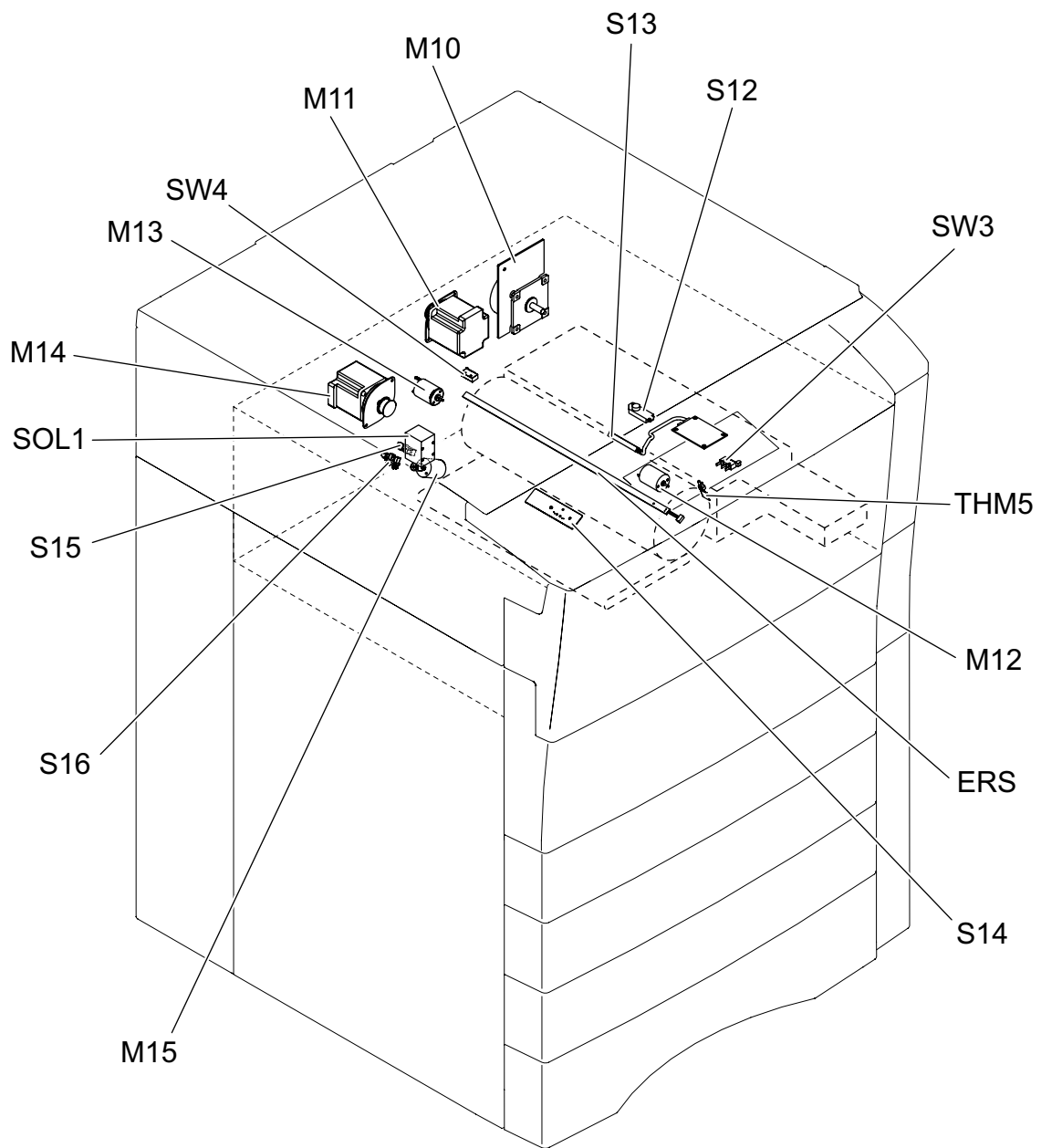

Fig. 2-14

b. Heater, thermostat, PC board

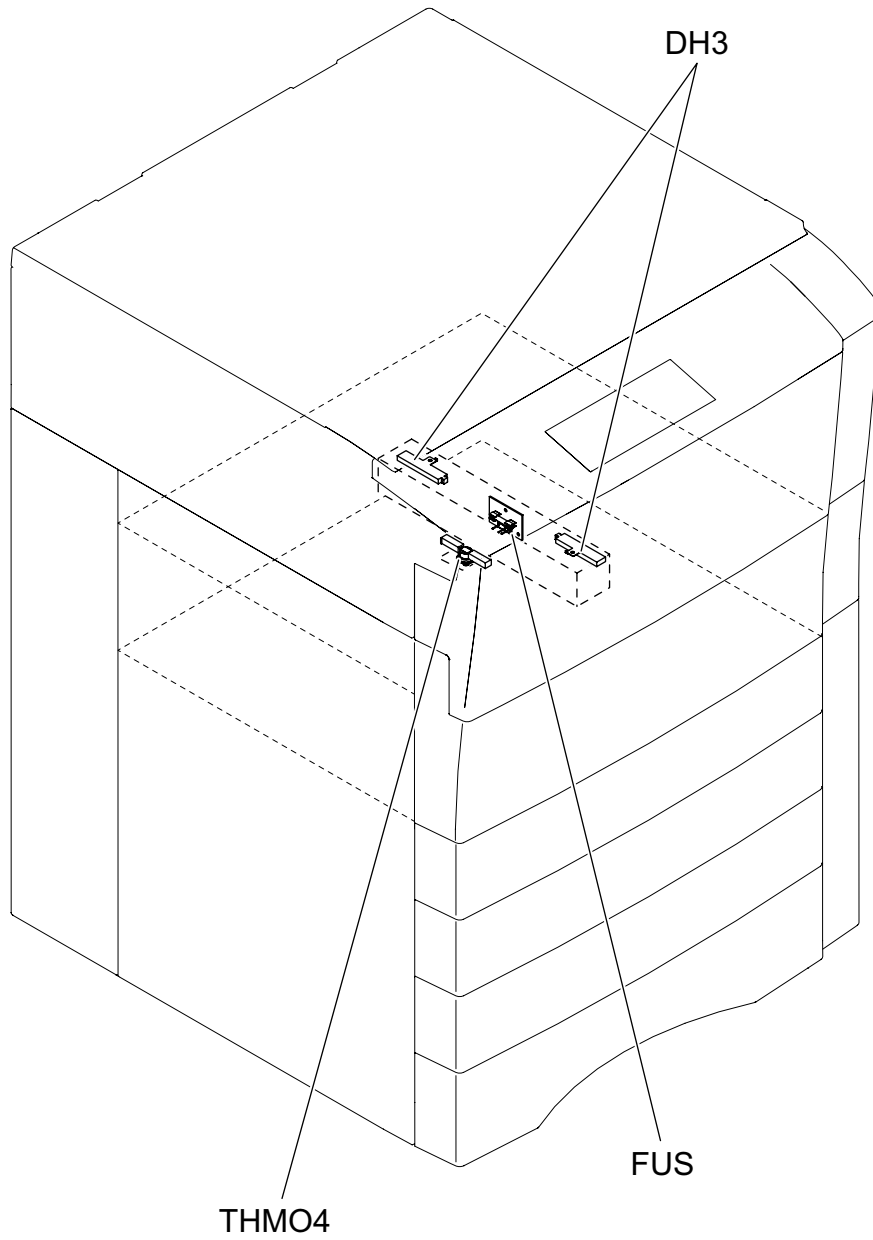

Fig. 2-15

[H] Paper transport unit

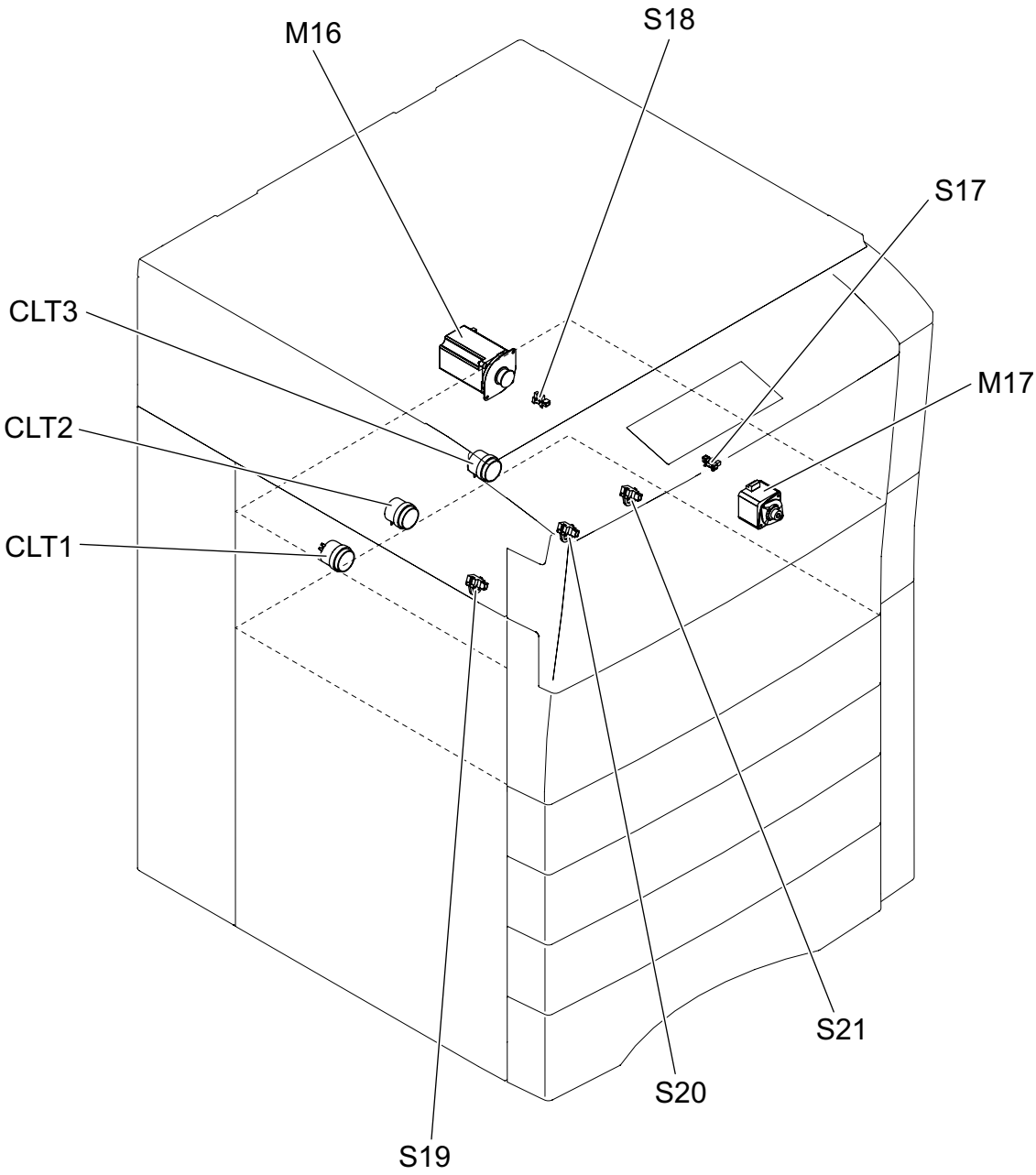

Fig. 2-16

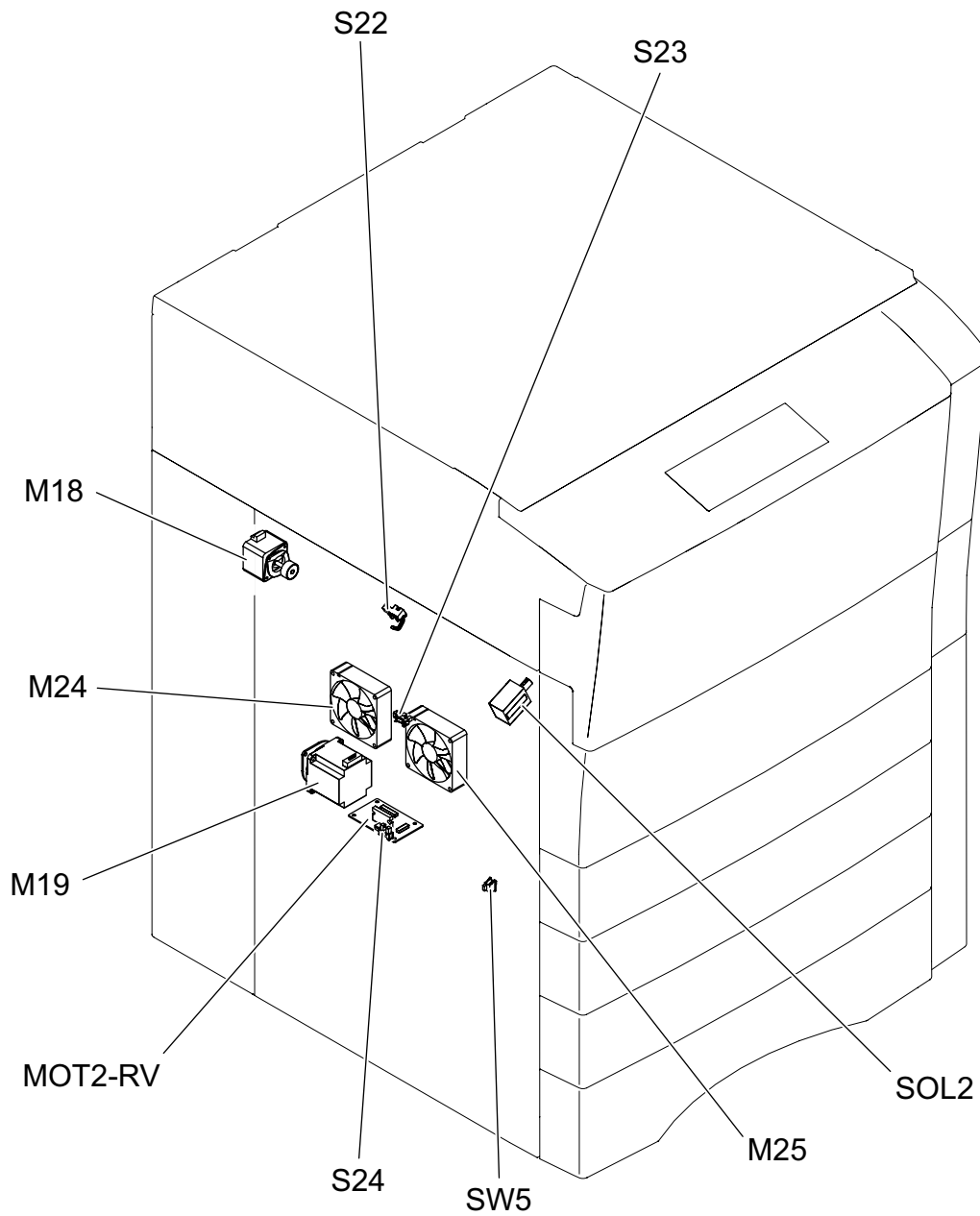

Fig. 2-17

[J] Equipment (left view)

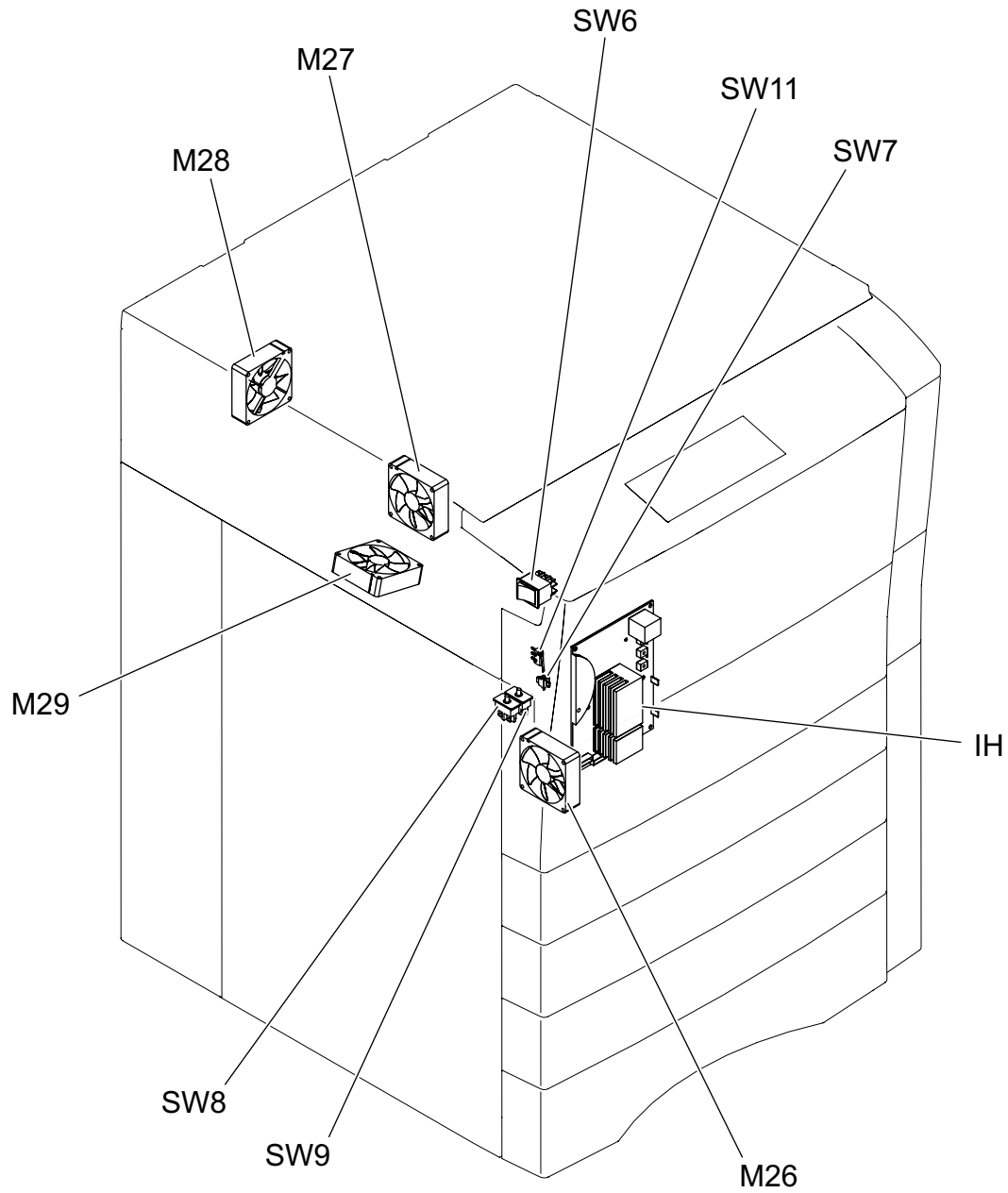

Fig. 2-18

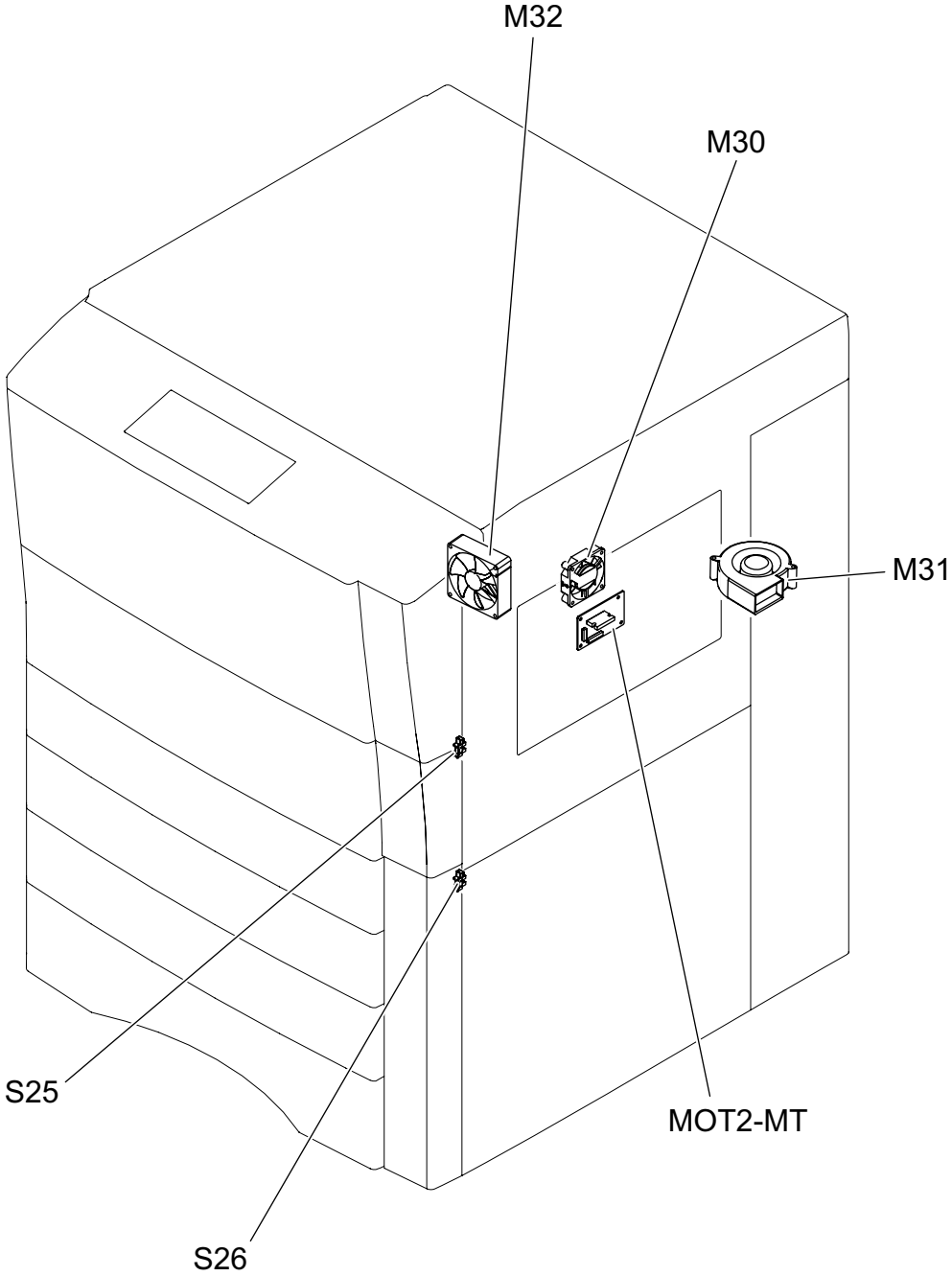

Fig. 2-19

[L] Bypass feed unit

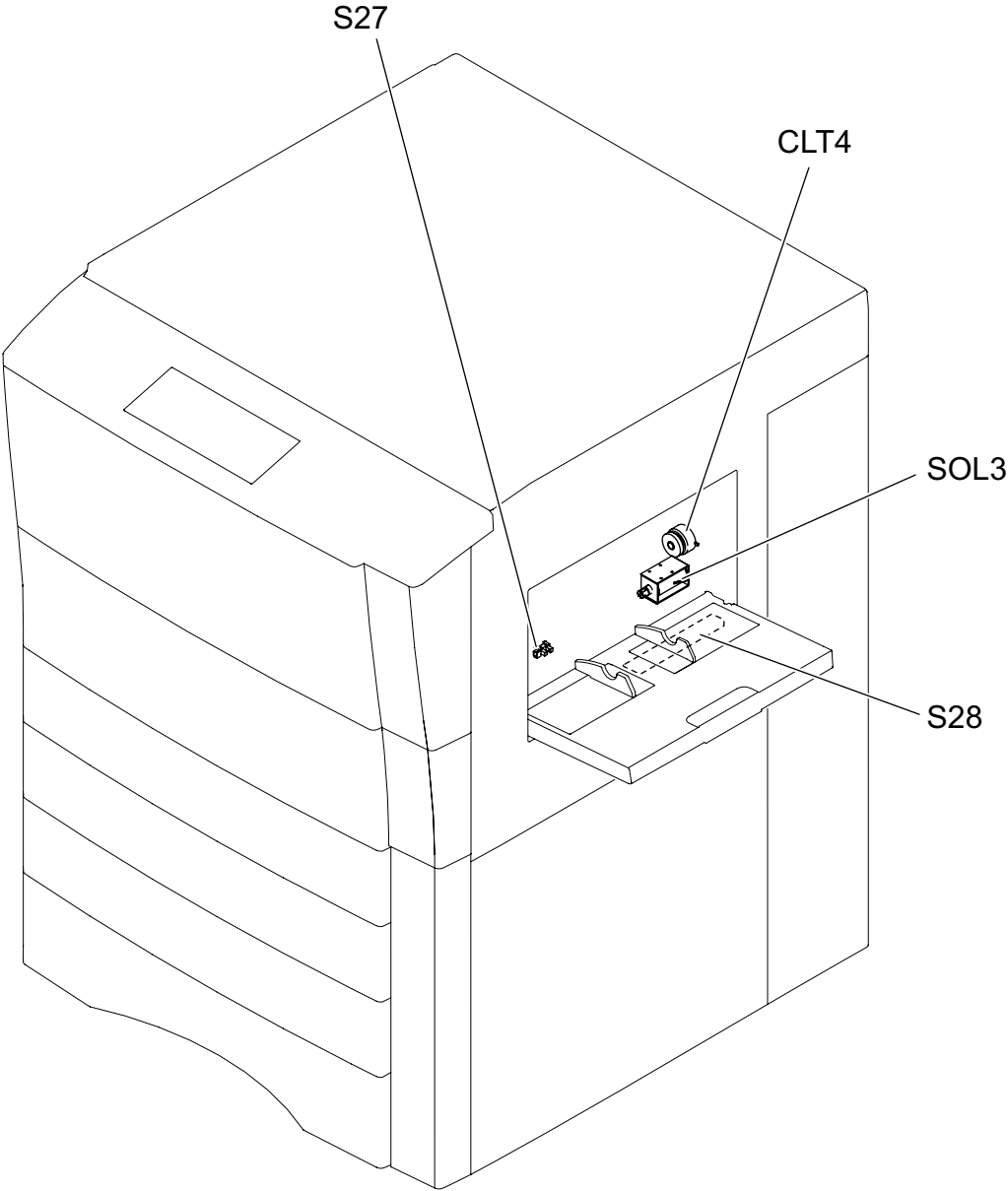

Fig. 2-20

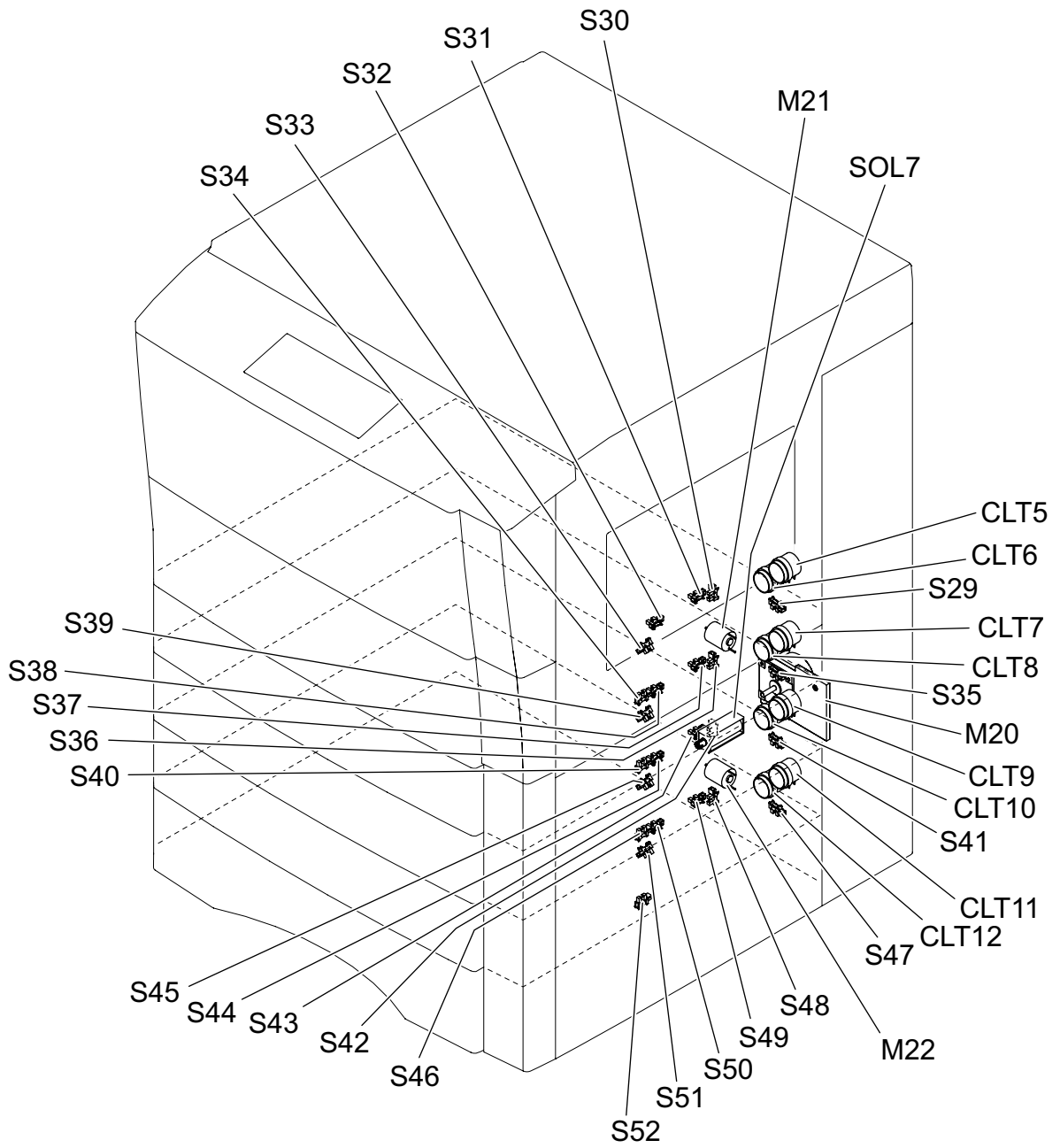

Fig. 2-21

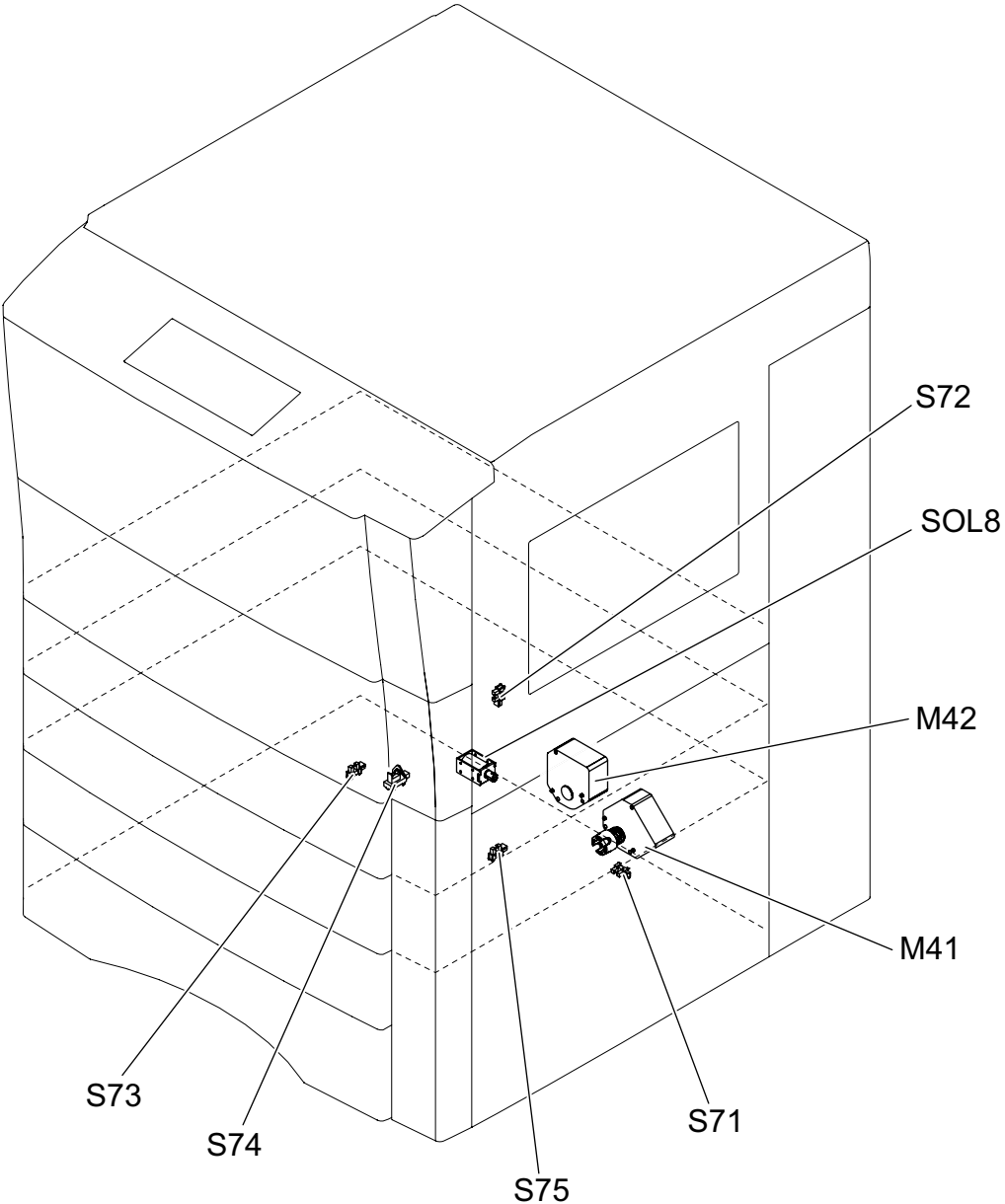

Fig. 2-22

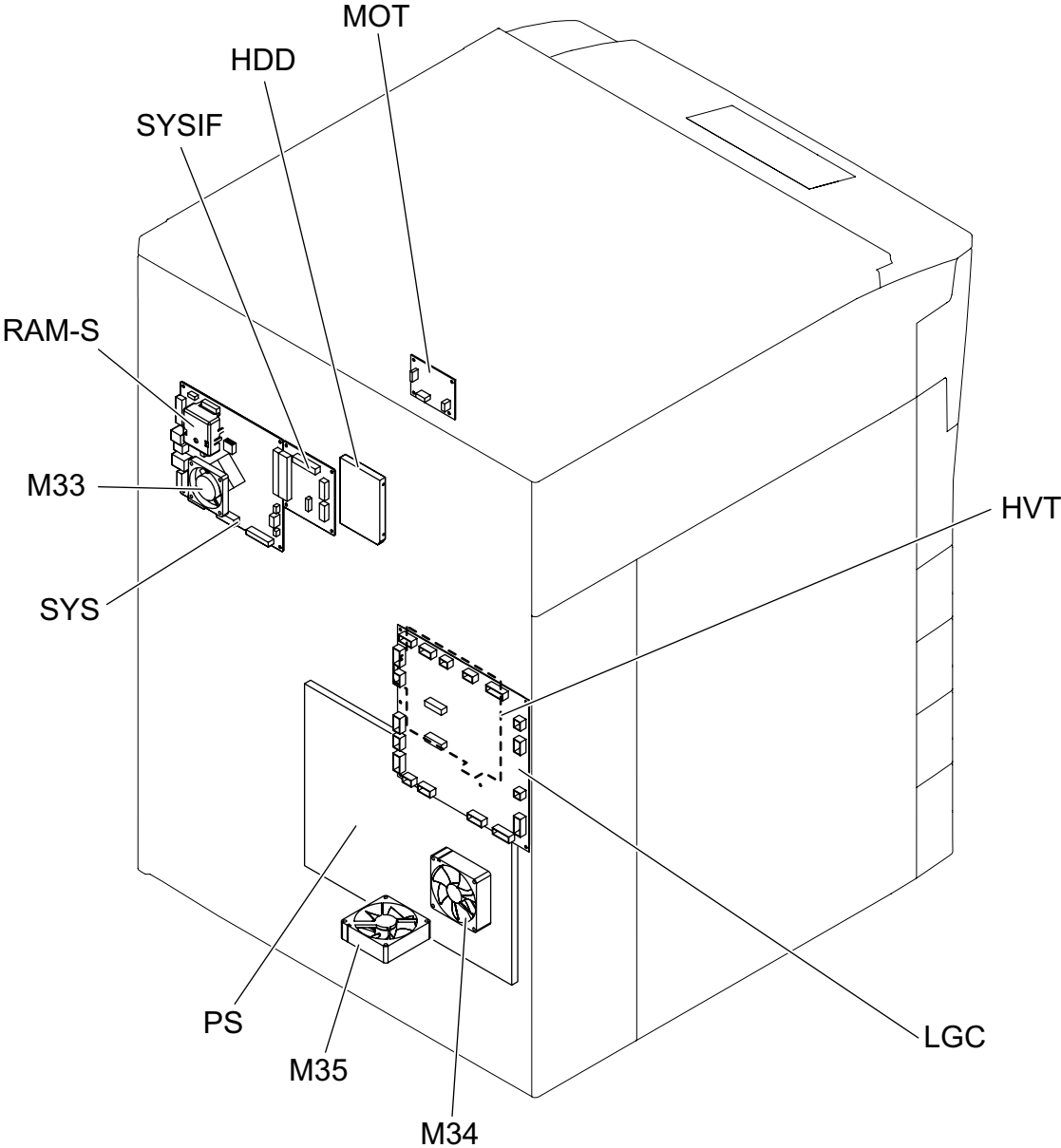

Fig. 2-23

[P] AC input section
a. e-STUDIO655: JPC model

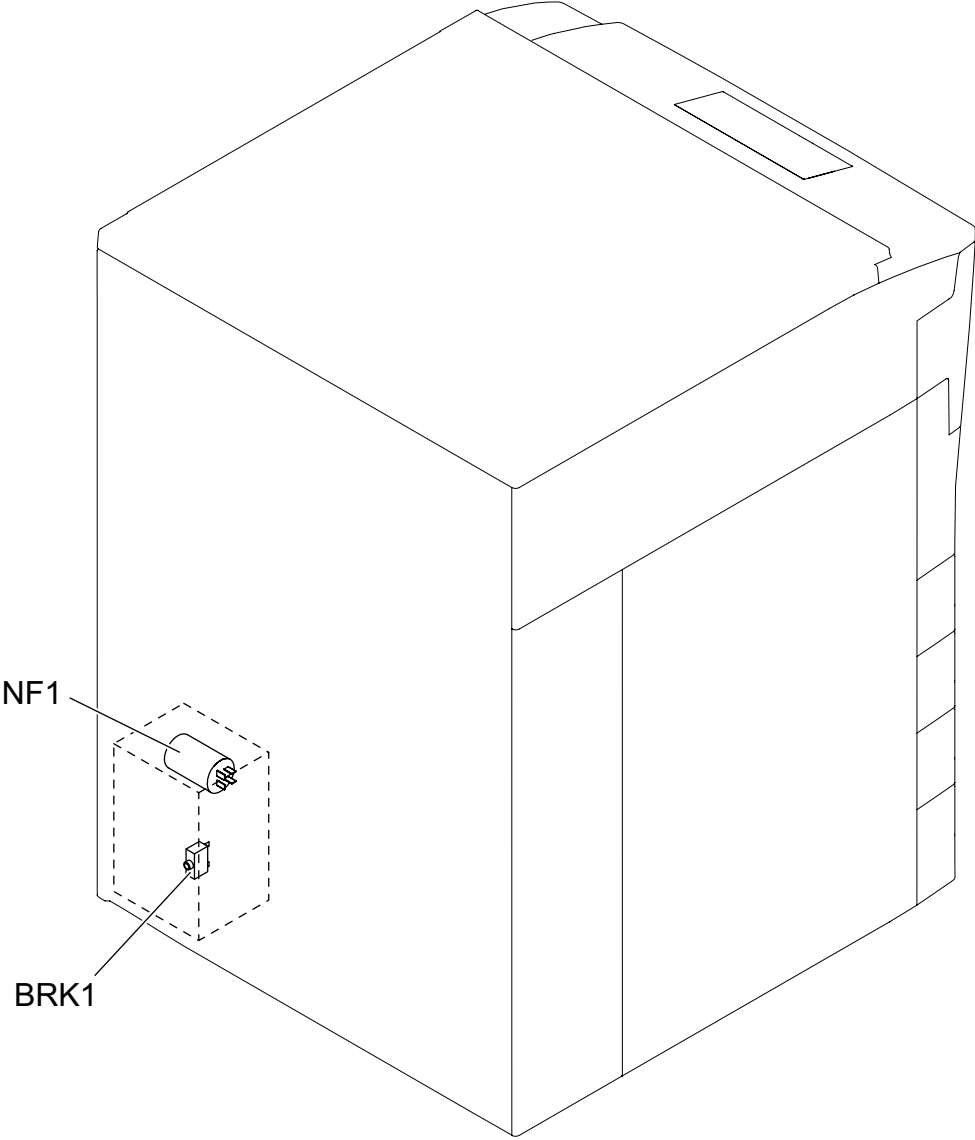

Fig. 2-24

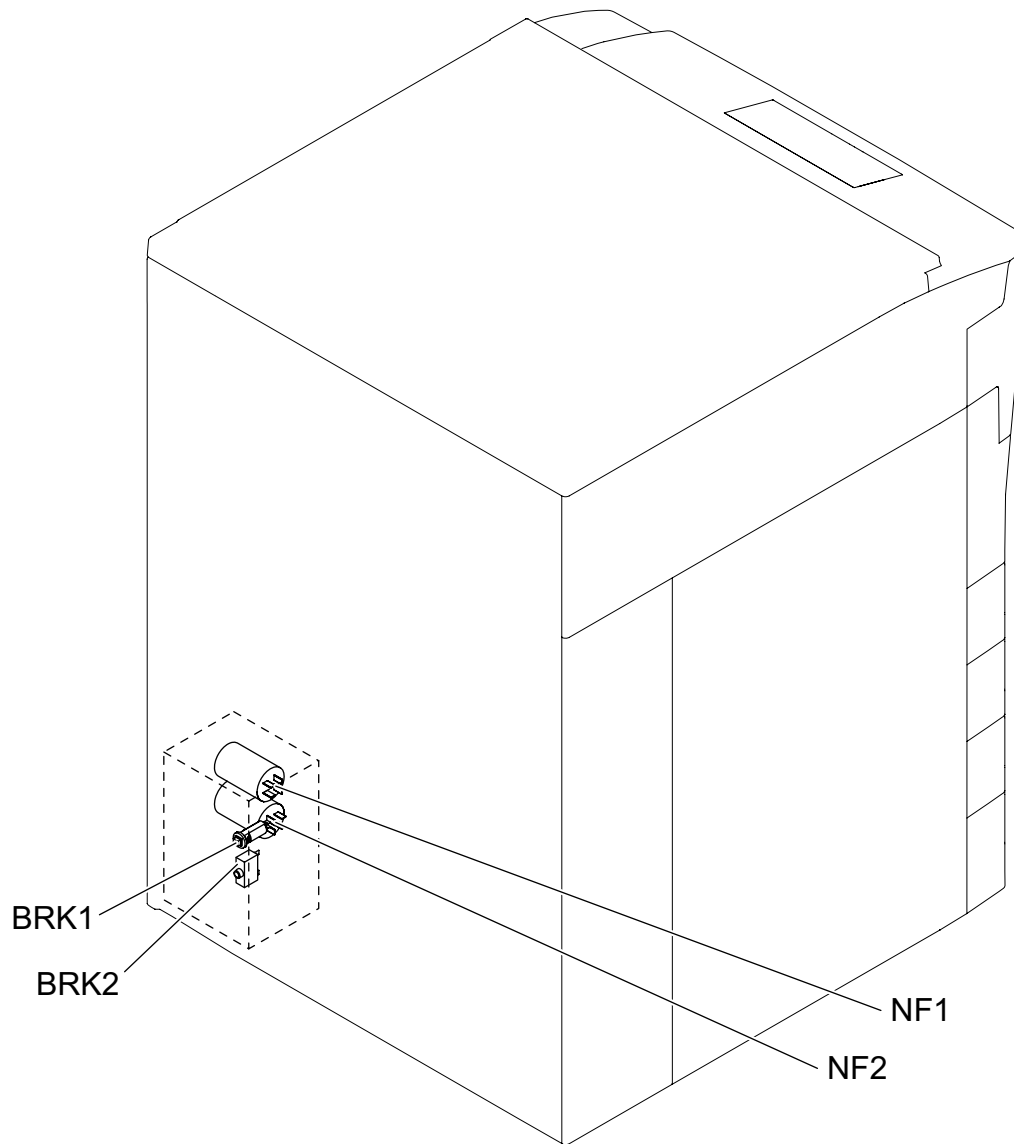

Fig. 2-25

- c. e-STUDIO555: NAD model,
e-STUDIO655: NAD/SAD/TWD model,
e-STUDIO755/855: NAD/SAD model

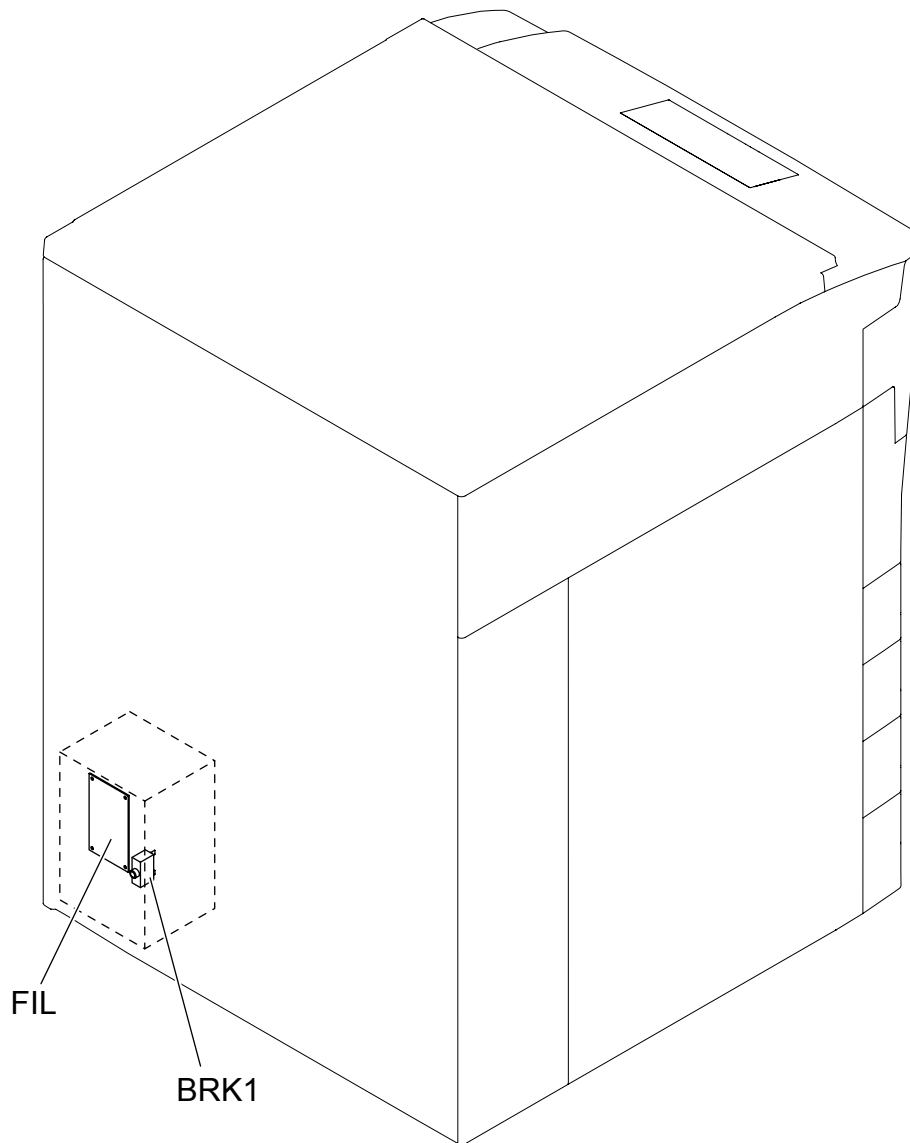

Fig. 2-26

- d. e-STUDIO555: ASD/AUD/MJD/CND model,
e-STUDIO655/755/855: ARD/ASD/AUD/MJD/CND model,
e-STUDIO755/855: TWD model

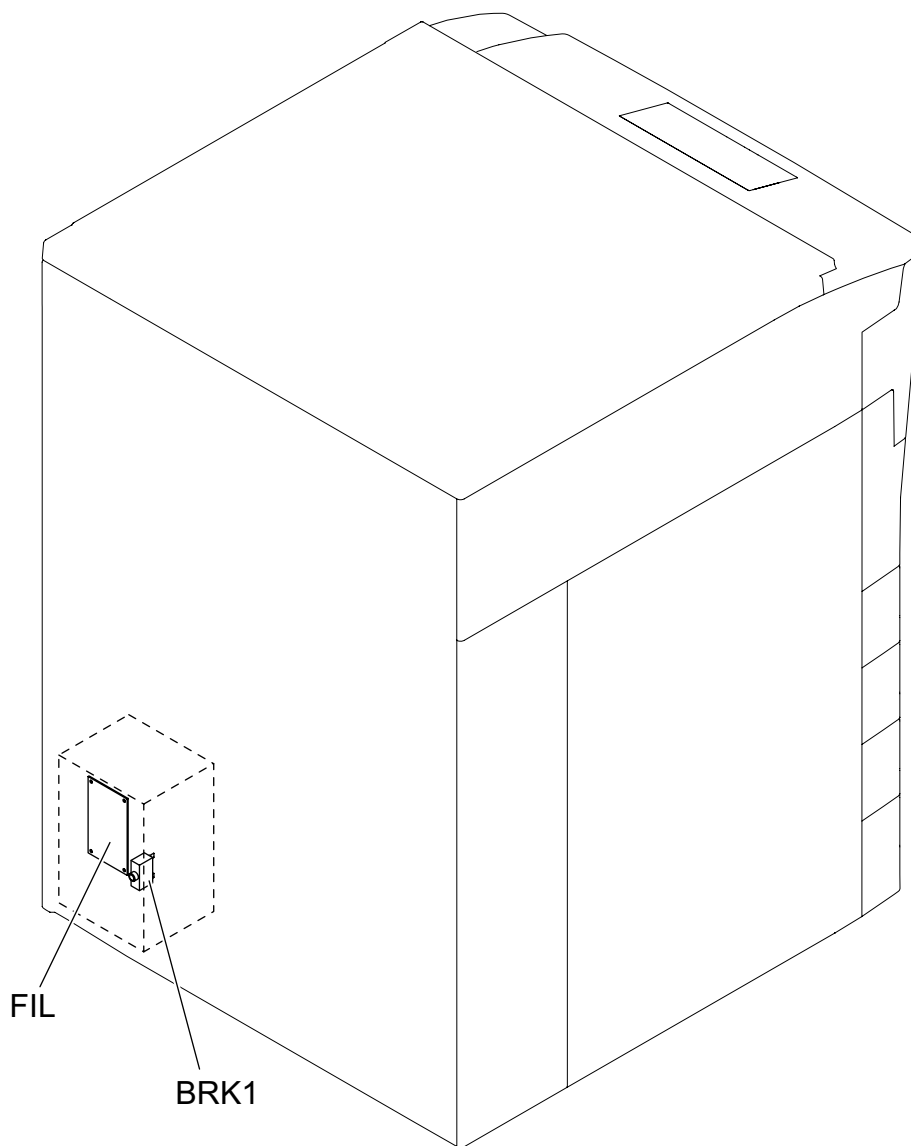

Fig. 2-27

[Q] Reversing automatic document feeder (RADF)

a. Sensor, Switch

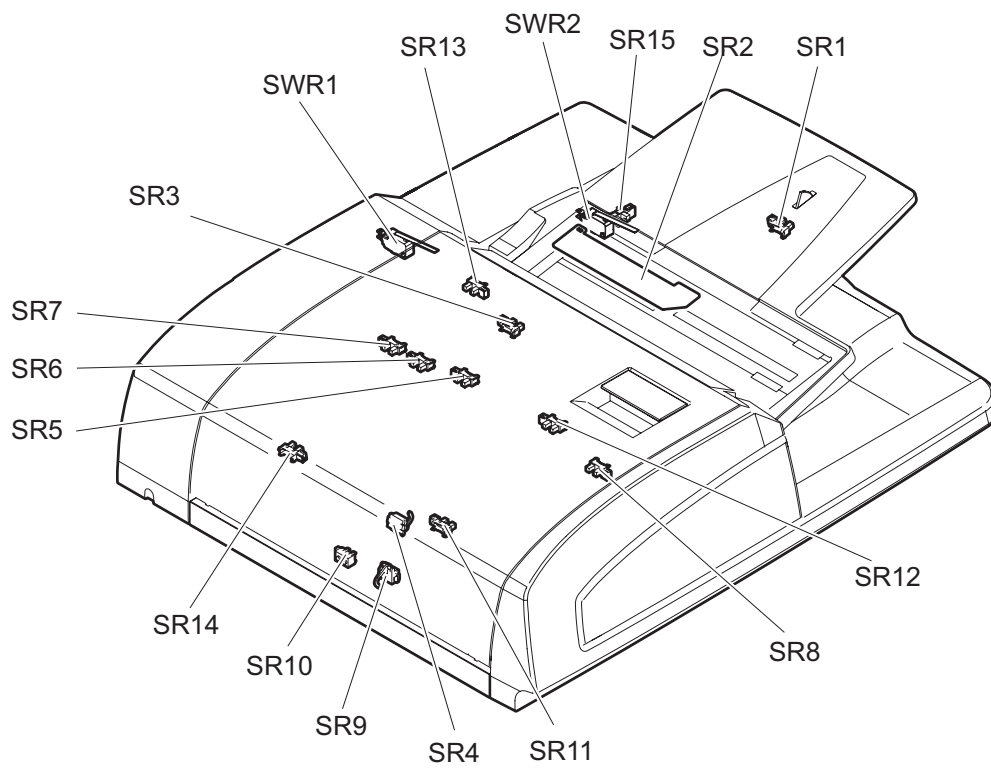

Fig. 2-28

b. Motor, fan, solenoid, PC board

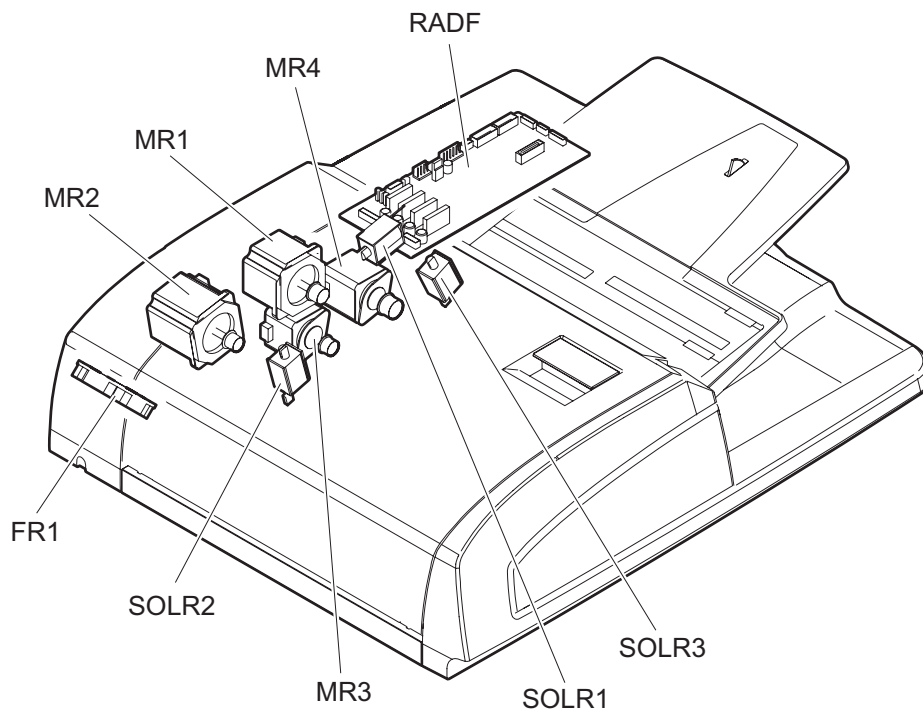

Fig. 2-29

2.3 Symbols and Functions of Various Components

The column "P-I" shows the page and item number in the parts list.

2.3.1 Motors

Symbol	Name	Function	Remarks	P-I
M1	SCAN-MOT Scan motor	Driving the carriages	Fig. 2-5 Fig. 2-6	35-6
M2	POL-MOT Polygonal motor	Driving the polygonal mirror	Fig. 2-9 Fig. 2-10	32-1A 32-1B
M3	FUS-MOT Fuser motor	Driving the fuser	Fig. 2-11	24-5
M4	WEB-MOT Web motor	Reeling in the cleaning web	Fig. 2-11	25-16
M5	TNR-MOT New toner supply motor	Rotating the toner cartridge	Fig. 2-12	45-27
M6	TNR-TR-MOT New toner transport motor	Transporting toner from the toner cartridge to the developer unit	Fig. 2-12	45-26
M7	HOP-MOT Hopper motor	Driving the recycle toner hopper	Fig. 2-13	47-15
M8	RCY-TNR-MOT Recycle toner transport motor	Transporting recycle toner from the drum cleaner unit to the toner hopper	Fig. 2-13	47-15
M9	USD-TNR-MOT Used toner transport motor	Transporting used toner scraped off from the transfer belt with the transfer belt cleaning blade	Fig. 2-13	46-2
M10	DEV-MOT Developer unit motor	Driving the developer	Fig. 2-14	42-22
M11	DRM-MOT Drum motor	Driving the drum	Fig. 2-14	41-18
M12	CH-CLN-MOT Wire cleaner drive motor	Driving the charger wire cleaner	Fig. 2-14	39-8
M13	DRM-CLN-MOT Cleaning brush drive motor	Driving the cleaning brush and transporting recycle toner	Fig. 2-14	31-12
M14	TRB-MOT Transfer belt motor	Driving the transfer belt	Fig. 2-14	18-26
M15	TRB-CAM-MOT Transfer belt cam motor	Driving the contact/release movement of the transfer belt	Fig. 2-14	18-7
M16	RGST-MOT Registration motor	Driving the registration roller	Fig. 2-16	16-26
M17	MT-MOT Transport motor	Driving the intermediate transport roller	Fig. 2-16	17-2
M18	EXIT-MOT Exit motor	Driving the exit roller	Fig. 2-17	13-24
M19	REV-MOT Reverse motor	Driving the reverse section	Fig. 2-17	13-5
M20	FEED-MOT Feed motor	Driving the feed roller and pickup roller of each drawer or the bypass feed unit	Fig. 2-21	6-2
M21	CST-TRY-MOT1 Tray-up motor-1	Lifting up the trays in the 1st and 2nd drawers	Fig. 2-21	6-20
M22	CST-TRY-MOT2 Tray-up motor-2	Lifting up the trays in the 3rd and 4th drawers (Only for JPC model of all equipments)	Fig. 2-21	6-20
M23	SLG-FAN-MOT SLG board cooling fan	Cooling down the SLG board	Fig. 2-5 Fig. 2-6	34-10
M24	REV-FAN-MOT1 Reverse section cooling fan-1	Cooling down the reverse section (rear side)	Fig. 2-17	15-12
M25	REV-FAN-MOT2 Reverse section cooling fan-2	Cooling down the reverse section (front side)	Fig. 2-17	15-12

Symbol	Name	Function	Remarks	P-I
M26	IH-FAN-MOT IH board cooling fan	Cooling down the IH board	Fig. 2-18	24-17
M27	DCT-O-FAN-MOT Duct out fan	Suctioning ozone generated at charging	Fig. 2-18	33-3
M28	FUS-FAN-MOT Fuser cooling fan	Cooling down the fuser	Fig. 2-18	33-3
M29	EXIT-FAN-MOT Exit section cooling fan	Cooling down the exit section	Fig. 2-18	33-3
M30	DCT-I-FAN-MOT Duct in fan	Cooling down the developer unit	Fig. 2-19	42-25
M31	DEV-FAN-MOT Developer unit fan	Suctioning toner	Fig. 2-19	42-13
M32	LSU-FAN-MOT Laser unit cooling fan	Cooling down the laser unit	Fig. 2-19	32-9
M33	SYS-FAN-MOT SYS board cooling fan	Cooling down the SYS board, SYSIF board and hard disk	Fig. 2-23	54-8
M34	PS-FAN-MOT1 Switching regulator cooling fan-1	Cooling down the switching regulator (rear side)	Fig. 2-23	52-14
M35	PS-FAN-MOT2 Switching regulator cooling fan-2	Cooling down the switching regulator (lower side)	Fig. 2-23	52-14
M41	LCF-TRY-MOT Tandem LCF tray-up motor	Lifting up the tray in the tandem LCF (Only for NAD/SAD/ARD/ASD/AUD/MJD/CND/TWD model of all equipments)	Fig. 2-22	31-34
M42	LCF-ENDF-MOT Tandem LCF end fence motor	Driving the end fence in the tandem LCF (Only for NAD/SAD/ARD/ASD/AUD/MJD/CND/TWD model of all equipments)	Fig. 2-22	9-22
MR1	Original feed motor	Driving the original feed roller, pickup roller and registration roller	Fig. 2-29	87-14
MR2	Read motor	Transporting originals by driving the intermediate transport roller, front read roller, rear read roller and reverse registration roller	Fig. 2-29	87-7
MR3	Original reverse motor	Driving the original reverse roller	Fig. 2-29	87-28
MR4	Original exit motor	Driving the original exit roller	Fig. 2-29	87-9
FR1	RADF cooling fan	Cools off the RADF drive section.	Fig. 2-29	89-16

2.3.2 Sensors and switches

Symbol	Name	Function	Remarks	P-I
S1-5	APS1-3, APS-C, APS-R Automatic original detection sensor	Detecting original sizes	Fig. 2-5 Fig. 2-6	38-7 34-14
S6	HOME-SNR Carriage home position sensor	Detecting the carriage home position	Fig. 2-5 Fig. 2-6	34-101
S7	TEMP/HUMI-SNR Temperature/humidity sensor	Detecting the ambient temperature/ humidity of the equipment	Fig. 2-8	3-34
S8	WEB-SNR Web detection sensor	Detecting the reeled amount of the cleaning web	Fig. 2-11	25-112
S9	FUS-TR-SNR Fuser transport sensor	Detecting the transporting status of paper at the fuser unit	Fig. 2-11	25-112
S10	TNR-EMP-SNR Toner cartridge empty sensor	Detecting the remaining amount of new toner	Fig. 2-12	45-56
S11	USD-TNR-FLL-SNR Toner bag full detection sensor	Detecting the full status of used toner in the toner bag	Fig. 2-13	46-17
S12	ATTNR-SNR Auto-toner sensor	Detecting the toner density in the developer unit	Fig. 2-14	44-26
S13	DRUM-SUF-SNR Drum surface potential sensor	Detecting the drum surface potential at charging (This sensor is composed of the detection section and the board section)	Fig. 2-14	5-13
S14	TNR-LVL-SNR Image quality sensor	Detecting the density of toner image (test pattern) developed on the drum surface	Fig. 2-14	50-16
S15	TRB-SNR2 Transfer belt release detection sensor	Detecting the releasing status of the transfer belt	Fig. 2-14	18-2
S16	TRB-SNR1 Transfer belt contact detection sensor	Detecting the contacting status of the transfer belt	Fig. 2-14	18-3
S17	MID-TR-SNR Intermediate transport sensor	Detecting the paper transport between the paper feeding system and the registration roller	Fig. 2-16	17-5
S18	RGST-SNR Registration sensor	Detecting the paper transport at the registration roller section	Fig. 2-16	16-6
S19	HRZ-TR-SNR1 Horizontal transport sensor-1	Detecting the paper transport at the entrance of the horizontal transport path	Fig. 2-16	20-23
S20	HRZ-TR-SNR2 Horizontal transport sensor-2	Detecting the paper transport at the middle of the horizontal transport path	Fig. 2-16	20-23
S21	HRZ-TR-SNR3 Horizontal transport sensor-3	Detecting the paper transport at the exit of the horizontal transport path	Fig. 2-16	20-23
S22	EXIT-SNR Exit sensor	Detecting paper exit	Fig. 2-17	15-25
S23	REV-SNR1 Reverse sensor-1	Detecting the paper transport at the upper section of the reverse transport path	Fig. 2-17	15-14
S24	REV-SNR2 Reverse sensor-2	Detecting the paper transport at the lower section of the reverse transport path	Fig. 2-17	15-14
S25	SFB-COV-SNR Bypass feed unit cover sensor	Detecting the opening/closing status of the bypass feed unit cover	Fig. 2-19	29-7
S26	FEED-COV-SNR Feed cover sensor	Detecting the opening/closing status of the feed cover	Fig. 2-19	29-7
S27	SFB-FEED-SNR Bypass feed sensor	Detecting the presence of the paper on the bypass feed unit	Fig. 2-20	10-23

Symbol	Name	Function	Remarks	P-I
S28	SFB-SIZE-SNR Bypass paper size detection sensor	Detecting the width of the paper on the bypass feed unit	Fig. 2-20	12-9
S29	CST1-SNR 1st drawer detection sensor	Detecting the presence of the 1st drawer	Fig. 2-21	7-18
S30	CST1-BTM-SNR 1st drawer bottom sensor	Detecting the lowering status of the tray in the 1st drawer	Fig. 2-21	30-26
S31	CST1-EMP-SNR 1st drawer empty sensor	Detecting the presence of the paper in the 1st drawer	Fig. 2-21	7-18
S32	CST1-TRY-SNR 1st drawer tray-up sensor	Detecting the lifting status of the tray in the 1st drawer	Fig. 2-21	7-18
S33	CST1-TR-SNR 1st drawer transport sensor	Detecting the paper transport at the paper feeding system of the 1st drawer	Fig. 2-21	7-18
S34	CST1-FEED-SNR 1st drawer feed sensor	Detecting the paper feeding status of the 1st drawer	Fig. 2-21	7-18
S35	CST2-SNR 2nd drawer detection sensor	Detecting the presence of the 2nd drawer	Fig. 2-21	7-18
S36	CST2-BTM-SNR 2nd drawer bottom sensor	Detecting the lowering status of the tray in the 2nd drawer	Fig. 2-21	30-26
S37	CST2-EMP-SNR 2nd drawer empty sensor	Detecting the presence of the paper in the 2nd drawer	Fig. 2-21	7-18
S38	CST2-TRY-SNR 2nd drawer tray-up sensor	Detecting the lifting status of the tray in the 2nd drawer	Fig. 2-21	7-18
S39	CST2-TR-SNR 2nd drawer transport sensor	Detecting the paper transport at the paper feeding system of the 2nd drawer	Fig. 2-21	7-18
S40	CST2-FEED-SNR 2nd drawer feed sensor	Detecting the paper feeding status of the 2nd drawer	Fig. 2-21	7-18
S41	CST3-SNR 3rd drawer detection sensor	Detecting the presence of the 3rd drawer or the tandem LCF	Fig. 2-21	7-18
S42	CST3-BTM-SNR 3rd drawer bottom sensor	Detecting the lowering status of the tray in the 3rd drawer (Only for JPC model of all equipments)	Fig. 2-21	30-26
S43	CST3-EMP-SNR 3rd drawer / tandem LCF empty sensor	Detecting the presence of the paper in the 3rd drawer or the tandem LCF	Fig. 2-21	7-18
S44	CST3-TRY-SNR 3rd drawer / tandem LCF tray-up sensor	Detecting the lifting status of the tray in the 3rd drawer or the tandem LCF	Fig. 2-21	7-18
S45	CST3-TR-SNR 3rd drawer / tandem LCF transport sensor	Detecting the paper transport at the paper feeding system of the 3rd drawer or the tandem LCF	Fig. 2-21	7-18
S46	CST3-FEED-SNR 3rd drawer / tandem LCF feed sensor	Detecting the paper feeding status of the 3rd drawer or the tandem LCF	Fig. 2-21	7-18
S47	CST4-SNR 4th drawer detection sensor	Detecting the presence of the 4th drawer (Only for JPC model of all equipments)	Fig. 2-21	7-18
S48	CST4-BTM-SNR 4th drawer bottom sensor	Detecting the lowering status of the tray in the 4th drawer (Only for JPC model of all equipments)	Fig. 2-21	30-26
S49	CST4-EMP-SNR 4th drawer empty sensor	Detecting the presence of the paper in the 4th drawer (Only for JPC model of all equipments)	Fig. 2-21	7-18
S50	CST4-TRY-SNR 4th drawer tray-up sensor	Detecting the lifting status of the tray in the 4th drawer (Only for JPC model of all equipments)	Fig. 2-21	7-18
S51	CST4-TR-SNR 4th drawer transport sensor	Detecting the paper transport at the paper feeding system of the 4th drawer (Only for JPC model of all equipments)	Fig. 2-21	7-18

Symbol	Name	Function	Remarks	P-I
S52	CST4-FEED-SNR 4th drawer feed sensor	Detecting the paper feeding status of the 4th drawer (Only for JPC model of all equipments)	Fig. 2-21	7-18
S53	PLTN-SNR Platen sensor	Detecting the opening/closing status of the RADF	Fig. 2-5 Fig. 2-6	35-21
S71	LCF-BTM-SNR Tandem LCF bottom sensor	Detecting the lowering status of the tray in the tandem LCF (Only for NAD/SAD/ARD/ASD/AUD/MJD/CND/TWD model of all equipments)	Fig. 2-22	8-14
S72	LCF-MST-SNR Standby side mis-stacking sensor	Detecting the paper mis-stacking at the standby side of the tandem LCF (Only for NAD/SAD/ARD/ASD/AUD/MJD/CND/TWD model of all equipments)	Fig. 2-22	8-14
S73	LCF-ENDF-HP-SNR End fence home position sensor	Detecting the end fence home position in the tandem LCF (Only for NAD/SAD/ARD/ASD/AUD/MJD/CND/TWD model of all equipments)	Fig. 2-22	8-14
S74	LCF-EMP-SNR Standby side empty sensor	Detecting the presence of the paper at the standby side of the tandem LCF (Only for NAD/SAD/ARD/ASD/AUD/MJD/CND/TWD model of all equipments)	Fig. 2-22	9-37
S75	LCF-ENDF-STP-SNR End fence stop position sensor	Detecting the end fence stop position in the tandem LCF (Only for NAD/SAD/ARD/ASD/AUD/MJD/CND/TWD model of all equipments)	Fig. 2-22	8-14
SW1	FSR-SW Fuser detection switch	Supplying or shutting off AC power to the damp heater according to the installation status of the fuser unit (Not installed: Shut off)	Fig. 2-11	24-9
SW2	TNR-SW Toner cartridge detection switch	Detecting the presence of the toner cartridge	Fig. 2-12	45-18
SW3	DEV-SW Developer unit detection switch	Detecting the presence of the developer unit	Fig. 2-14	5-16
SW4	CH-CLN-POS-SW Wire cleaner position detection switch	Detecting the stop position of the charger wire cleaner	Fig. 2-14	39-13
SW5	EXIT-COV-SW Exit cover switch	Detecting the opening/closing status of the left lower cover	Fig. 2-17	15-11
SW6	MAIN-SW Main switch	Turning the power of the equipment ON/OFF	Fig. 2-18	29-11
SW7	U-FRNT-COV-SW Front cover switch	Detecting the opening/closing status of the front cover (upper)	Fig. 2-18	29-108
SW8	COV-INTLCK-SW Cover interlock switch	Supplying or shutting off AC power to the switching regulator (voltage-generating circuit interlocked with these covers) according to the opening/closing status of the front cover (lower) or left lower cover (Cover open: Shut off)	Fig. 2-18	29-24
SW9	IH-INTLCK-SW IH interlock switch	Supplying or shutting off AC power to the heater control PC board (IH board) according to the opening/closing status of the front cover (lower) or left lower cover (Cover open: Shut off)	Fig. 2-18	29-24
SW11	TNR-MOT-INTLCK-SW Toner motor interlock switch	Supplying or shutting off 24 V voltage to the new toner supply motor (M5) according to the opening/closing status of the front cover (upper) (Cover open: Shut off)	Fig. 2-18	29-109
SR1	Original tray sensor	Detects the length of the original set on the original tray.	Fig. 2-28	93-2
SR2	Original tray width sensor	Detects the width of the original set on the original tray.	Fig. 2-28	93-12

Symbol	Name	Function	Remarks	P-I
SR3	Original empty sensor	Detects the original set on the original tray.	Fig. 2-28	81-3
SR4	Original reading end sensor	Detecting the trailing edge of the original at the original scanning section	Fig. 2-28	85-5
SR5	Original registration sensor	Detects transport of the original at the registration roller section.	Fig. 2-28	82-14
SR6	Original width detection sensor-1	Detects the width of the original.	Fig. 2-28	82-14
SR7	Original width detection sensor-2	Detects the width of the original.	Fig. 2-28	82-14
SR8	Original width detection sensor-3	Detects the width of the original.	Fig. 2-28	82-14
SR9	Original intermediate transport sensor	Detects the original transported to the pre-scanning section.	Fig. 2-28	85-25
SR10	Original reading start sensor	Detects the leading edge of the original at the original scanning section.	Fig. 2-28	85-23
SR11	Original exit/reverse sensor	Detects the stop reference position for an original when in reverse.	Fig. 2-28	86-14
SR12	Original exit sensor	Detects the exit (transit) of an original.	Fig. 2-28	83-10
SR13	Original jam access cover opening/closing sensor	Detects opening/closing of the Jam access cover.	Fig. 2-28	81-3
SR14	Original reverse unit opening/closing sensor	Detecting the opening/closing status of the original reverse unit.	Fig. 2-28	85-6
SR15	RADF opening/closing sensor	Detecting the opening/closing status of the RADF.	Fig. 2-28	88-2
SWR1	Jam access cover opening/closing switch	Switches between cutoff and supply state of the 24 V power by opening/closing of the jam access cover.	Fig. 2-28	81-1
SWR2	RADF opening/closing switch	Detecting the opening/closing status of the RADF	Fig. 2-28	88-9

2.3.3 Electromagnetic spring clutches

Symbol	Name	Function	Remarks	P-I
CLT1	HRZ-DR-CLT1 Horizontal transport section driving clutch-1	Driving the horizontal transport section (transmitting the power of the fuser unit motor)	Fig. 2-16	19-21
CLT2	HRZ-DR-CLT2 Horizontal transport section driving clutch-2	Driving the horizontal transport rollers-1 and -2	Fig. 2-16	20-21
CLT3	HRZ-DR-CLT3 Horizontal transport section driving clutch-3	Driving the horizontal transport rollers-3 and -4	Fig. 2-16	20-21
CLT4	SFB-FEED-CLT Bypass feed clutch	Driving the transport roller, separation roller, feed roller and pickup roller of the bypass feed unit	Fig. 2-20	11-13
CLT5	CST1-TR-CLT 1st drawer transport clutch	Driving the transport roller of the 1st drawer	Fig. 2-21	7-26
CLT6	CST1-FEED-CLT 1st drawer feed clutch	Driving the separation roller, feed roller and pickup roller of the 1st drawer	Fig. 2-21	7-26
CLT7	CST2-TR-CLT 2nd drawer transport clutch	Driving the transport roller of the 2nd drawer	Fig. 2-21	7-26
CLT8	CST2-FEED-CLT 2nd drawer feed clutch	Driving the separation roller, feed roller and pickup roller of the 2nd drawer	Fig. 2-21	7-26
CLT9	CST3-TR-CLT 3rd drawer / tandem LCF transport clutch	Driving the transport roller of the 3rd drawer or the tandem LCF	Fig. 2-21	7-26
CLT10	CST3-FEED-CLT 3rd drawer / tandem LCF feed clutch	Driving the separation roller, feed roller and pickup roller of the 3rd drawer or the tandem LCF	Fig. 2-21	7-26
CLT11	CST4-TR-CLT 4th drawer transport clutch	Driving the transport roller of the 4th drawer (Only for JPC model of all equipments)	Fig. 2-21	7-26

Symbol	Name	Function	Remarks	P-I
CLT12	CST4-FEED-CLT 4th drawer feed clutch	Driving the separation roller, feed roller and pickup roller of the 4th drawer (Only for JPC model of all equipments)	Fig. 2-21	7-26

2.3.4 Solenoids

Symbol	Name	Function	Remarks	P-I
SOL1	SPRT-FING-SOL Drum separation finger solenoid	Driving the drum separation fingers	Fig. 2-14	31-17
SOL2	GATE-SOL Gate solenoid	Driving the exit/reverse gate	Fig. 2-17	15-2
SOL3	SFB-SOL Bypass pickup solenoid	Driving the lifting movement of the bypass pickup roller	Fig. 2-20	10-8
SOL7	LCF-PICK-SOL Tandem LCF pickup solenoid	Driving the lifting movement of the tandem LCF pickup roller (Only for NAD/SAD/ARD/ASD/AUD/MJD/CND/TWD model of all equipments)	Fig. 2-21	7-36
SOL8	LCF-ENDF-SOL Tandem LCF end fence solenoid	Driving of the lever to detect the paper mis-stacking at the standby side of the tandem LCF (Only for NAD/SAD/ARD/ASD/AUD/MJD/CND/TWD model of all equipments)	Fig. 2-22	8-9
SOLR1	Original pickup solenoid	Drives up and down the original pickup roller.	Fig. 2-29	89-10
SOLR2	Original reverse solenoid	Drives the reverse flapper. (Switches the flapper to the reverse side when turned to ON.)	Fig. 2-29	89-13
SOLR3	Original exit solenoid	Drives the exit flapper. (Switches the flapper to the original reverse tray side when turned to ON.)	Fig. 2-29	89-13

2.3.5 PC boards

Symbol	Name	Function	Remarks	P-I
CCD	PWA-F-CCD CCD driving PC board (CCD board)	Scanning originals with CCD	Fig. 2-5 Fig. 2-6	34-1
SLG	PWA-F-SLG Scanning section control PC board (SLG board)	Controlling the scanning section	Fig. 2-5 Fig. 2-6	38-1
DSP	PWA-F-DSP Display PC board (DSP board)	Controlling the whole control panel	Fig. 2-8	3-24
KEY	PWA-F-KEY1 Key PC board (KEY board)	Mounting the key switches and LEDs	Fig. 2-8	3-16
PLG	PWA-H-PLG Laser control PC board (PLG board)	Controlling the laser unit	Fig. 2-9 Fig. 2-10	32-7A 32-7B
LDR1	PWA-F-LDR1 Laser driving PC board-1 (LDR1 board)	Driving the laser diode	Fig. 2-9 Fig. 2-10	32-1A 32-1B
LDR2	PWA-F-LDR2 Laser driving PC board-2 (LDR2 board)	Driving the laser diode (Only for e-STUDIO755/855)	Fig. 2-10	32-1B
SNS	PWA-F-SNS H-sync detection PC board (SNS board)	Detecting the laser beam position	Fig. 2-9 Fig. 2-10	32-1A 32-1B

Symbol	Name	Function	Remarks	P-I
FUS	PWA-F-FUS Fuse PC board (FUS board)	Relaying power to the drum damp heater (Optional for NAD/MJD model, standard for other models)	Fig. 2-15	21-30
IH	PWA-F-IH Heater control PC board (IH board)	Controlling the IH coil of the fuser unit	Fig. 2-18	24-16
MOT	PWA-F-MOT Motor driving PC board (MOT board)	Controlling the drive of the drum motor and the transfer belt motor	Fig. 2-23	41-22
MOT2- MT	PWA-F-MOT2-MT Transport motor driving PC board (MOT2-MT board)	Controlling the drive of the transport motor	Fig. 2-19	17-10
MOT2- RV	PWA-F-MOT2-RV Reverse motor driving PC board (MOT2-RV board)	Controlling the drive of the reverse motor	Fig. 2-17	13-19
SYS	PWA-F-SYS System control PC board (SYS board)	Controlling the whole system and image processing	Fig. 2-23	54-21
SYSIF	PWA-F-SYSIF System interface PC board (SYSIF board)	Interface between the SYS board and each of the LCG, PLG and SLG boards.	Fig. 2-23	54-2
RAM-S	PWA-F-SRAM-S SRAM board <for SYS board>	Storing the setting or adjustment value, etc. used for the control by the system control PC board	Fig. 2-23	54-20
LGC	PWA-H-LGC Logic PC board (LGC board)	Controlling the print engine section	Fig. 2-23	53-2
FIL	PWA-F-FIL Filter PC board (FIL board)	Filtering out the AC power noise (Only for NAD/SAD/ARD/ASD/AUD/MJD/ CND/TWD model of all equipments)	Fig. 2-26 Fig. 2-27	52-24
RADF	PWA-F-RADF RADF control PC board (RADF board)	Controls the RADF.	Fig. 2-29	88-23

2.3.6 Lamps and heaters

Symbol	Name	Function	Remarks	P-I
EXP	LP-EXPO Exposure lamp	Exposing originals	Fig. 2-5 Fig. 2-6	36-3
ERS	LP-ERS Discharge LED	Eliminating residual charge on the drum surface	Fig. 2-14	39-11
IH-COIL	IH-COIL IH coil	Heating up the fuser roller	Fig. 2-11	26-5
DH1	SCN-DH-L Scanner damp heater (Left)	Preventing condensation of the mirrors of the carriage	Fig. 2-7	38-9
DH2	SCN-DH-R Scanner damp heater (Right)	Preventing condensation of the lens	Fig. 2-7	38-10
DH3	DRM-DH Drum damp heater	Preventing condensation of the drum	Fig. 2-15	21-28

2.3.7 Thermistors and thermostats

Symbol	Name	Function	Remarks	P-I
THM1	THMS-F-HTR Fuser roller front thermistor	Detecting the surface temperature of the front end of the fuser roller	Fig. 2-11	27-6
THM2	THMS-C-HTR Fuser roller center thermistor	Detecting the surface temperature of the center of the fuser roller	Fig. 2-11	27-6

Symbol	Name	Function	Remarks	P-I
THM3	THMS-R-HTR Fuser roller rear thermistor	Detecting the surface temperature of the rear end of the fuser roller	Fig. 2-11	27-6
THM4	THMS-L-HTR Pressure roller thermistor	Detecting the surface temperature of the pressure roller	Fig. 2-11	27-28
THM5	THMS-DRM Drum thermistor	Detecting the ambient temperature of the drum surface	Fig. 2-14	50-12
THMO1	THERMO-C-HTR Fuser roller center thermostat	Preventing overheating of the inside of the fuser unit	Fig. 2-11	27-4
THMO2	THERMO-S-HTR Fuser roller side thermostat	Preventing overheating of the inside of the fuser unit	Fig. 2-11	27-4
THMO3	THERMO-SCN-DH Scanner damp heater thermostat	Controlling the temperature of the scanner damp heater	Fig. 2-7	38-9
THMO4	THERMO-DRM-DH Drum damp heater thermostat	Controlling the temperature of the drum damp heater	Fig. 2-15	21-31

2.3.8 Transformer

Symbol	Name	Function	Remarks	P-I
HVT	PS-HVT High-voltage transformer	Generating high-voltage and supplying it to the following sections: <ul style="list-style-type: none"> • Main charger wire • Main charger grid • Developer bias • Transfer bias • Drum cleaning brush 	Fig. 2-23	53-7

2.3.9 Others

Symbol	Name	Function	Remarks	P-I
INV-EXP	INV-EXP Lamp inverter board	Controlling the exposure lamp	Fig. 2-5 Fig. 2-6	36-4
LCD	LCD LCD panel	Displaying each information	Fig. 2-8	3-23
TCP	TCP Touch panel	Entering each information	Fig. 2-8	3-22
INV-LCD	INV-LCD LCD inverter board	Controlling the LCD panel (touch panel)	Fig. 2-8	3-26
GLV	MIR-GLV Galvanic mirror	Adjusting the beam angle of the 2nd laser (Only for e-STUDIO755/855)	Fig. 2-10	32-1B
HDD	HDD Hard disk	Saving program data and image data	Fig. 2-23	54-11
PS	PS-ACC Switching regulator	Generating DC voltage and supplying it to each section of the equipment	Fig. 2-23	52-14
NF1	NS-FIL1 Noise filter-1	Filtering out the noise of the input AC power (Only for JPC model)	Fig. 2-24 Fig. 2-25	52-4 52-4B
NF2	NS-FIL2 Noise filter-2	Filtering out the noise of the AC power supplied to the fuser unit (Only for JPC model of e-STUDIO755/855)	Fig. 2-25	52-4
BRK1	BREAKER1 Breaker-1	Preventing overcurrent to the equipment	Fig. 2-24 Fig. 2-25 Fig. 2-26 Fig. 2-27	52-3A 52-3B 52-113
BRK2	BREAKER2 Breaker-2	Preventing overcurrent to the fuser unit (Only for JPC model of e-STUDIO755/855)	Fig. 2-25	52-3B

2.4 System Block Diagram

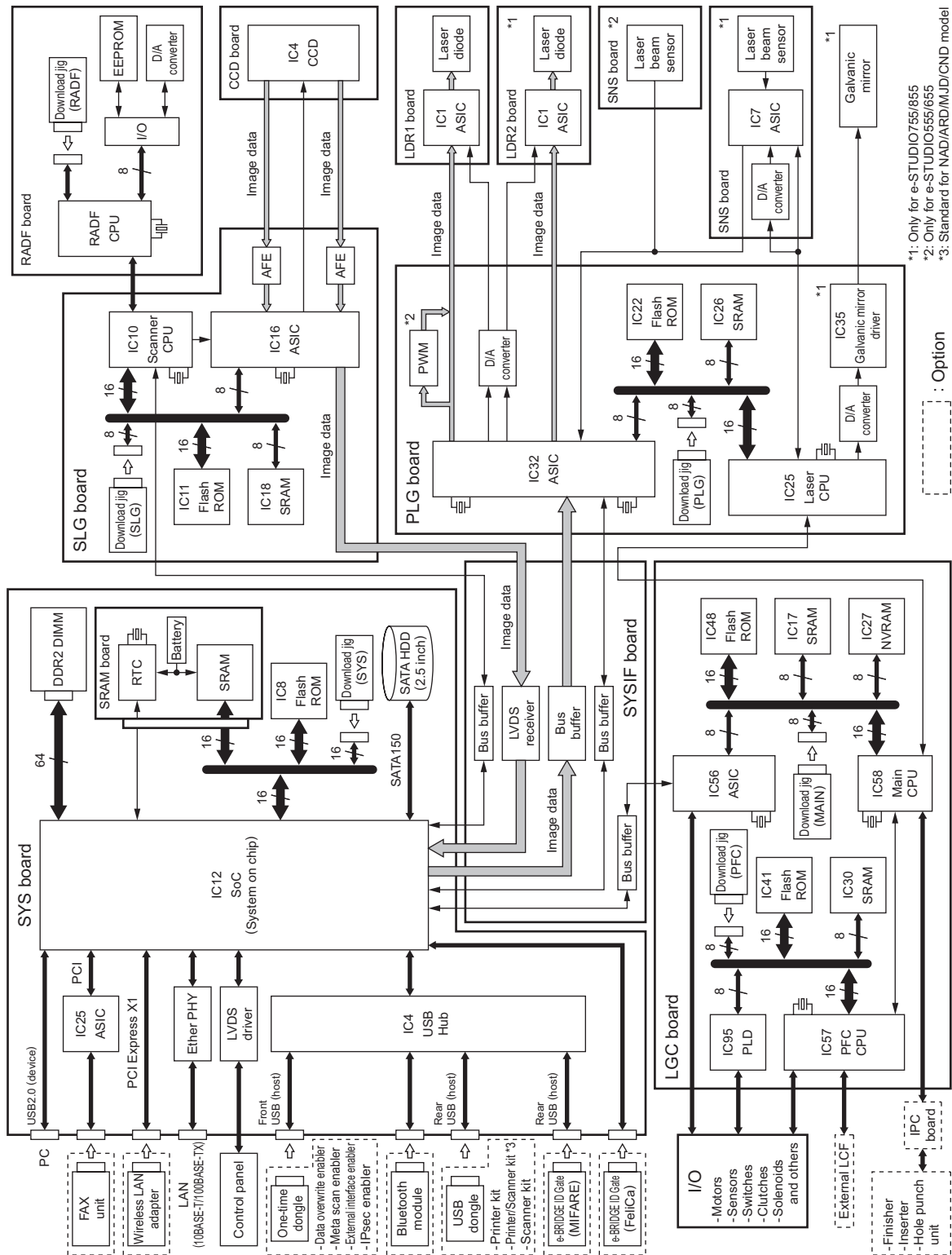

Fig. 2-30

2.5 Installation and Replacement of Covers

[A] Front cover (Upper/Lower)

- (1) Open the front cover (upper). Turn 2 hinge pins to point at the front side and pull them out upward. Then take off the front cover (upper).

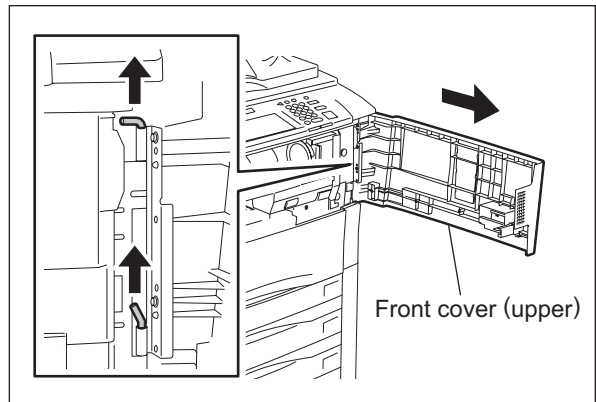

Fig. 2-31

- (2) Open the front cover (lower). Then take off the cover by lifting it up.

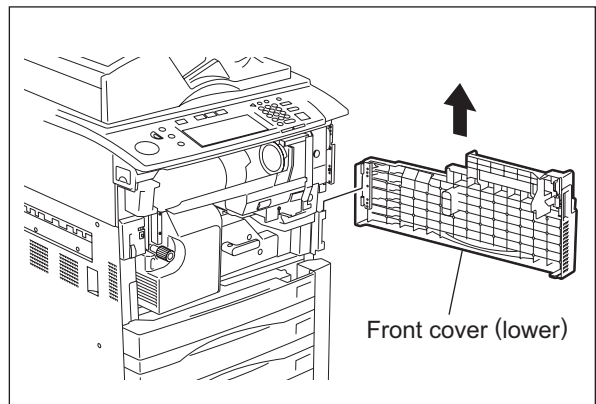

Fig. 2-32

[B] Front right inner cover

- (1) Take off the front cover (P.2-41 "[A] Front cover (Upper/Lower)").
- (2) Remove 2 screws to take off the front right inner cover.

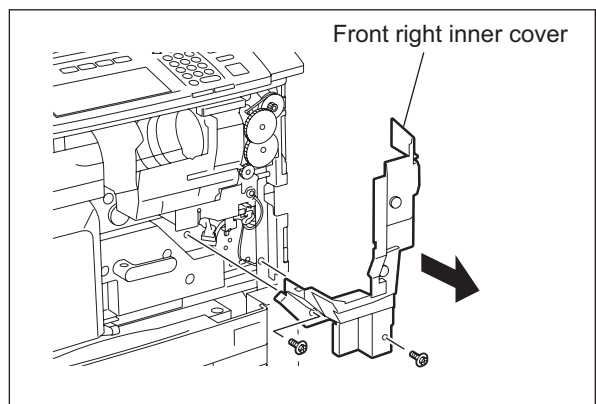

Fig. 2-33

[C] Top right cover

- (1) Remove 1 screw and open the RADF.
- (2) Slide the cover to the rear side to release the hook, and then take off the top right cover.

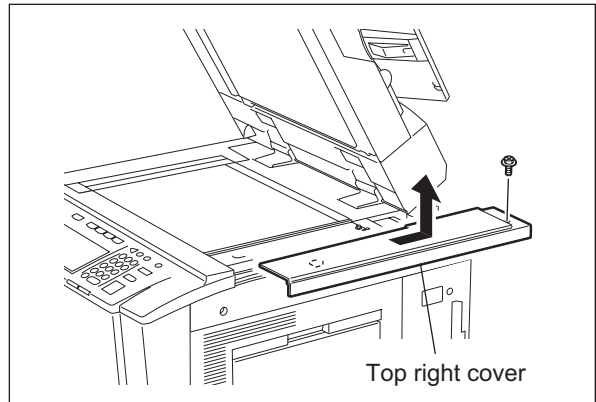

Fig. 2-34

[D] Top left cover

- (1) Remove 1 screw and open the RADF.
- (2) Slide the cover to the rear side to release the hook, and then take off the top left cover.

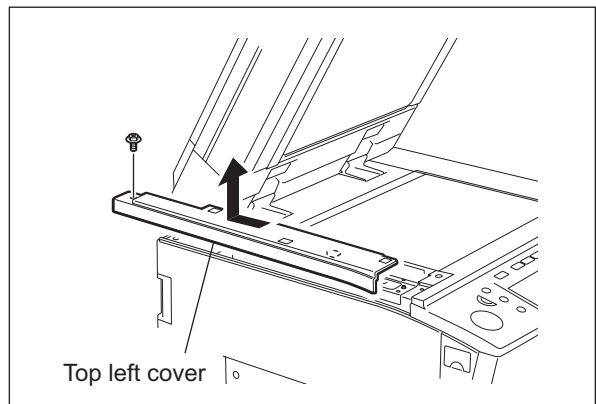

Fig. 2-35

[E] Top rear cover

- (1) Take off the RADF
(P.15-14 "15.5.1 RADF").
- (2) Take off the top right cover
(P.2-42 "[C] Top right cover").
- (3) Take off the top left cover
(P.2-42 "[D] Top left cover").
- (4) Remove 2 screws to take off the top rear cover.

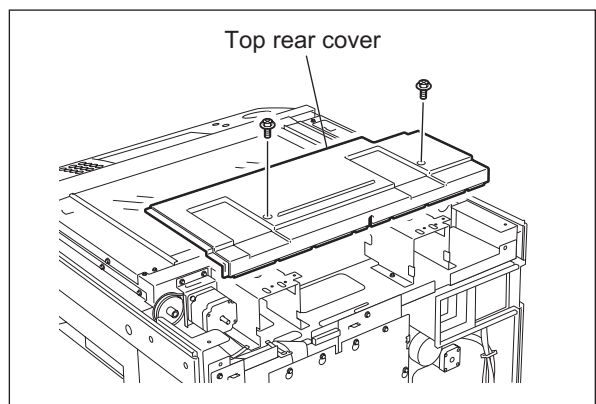

Fig. 2-36

[F] Right upper cover

- (1) Take off the top right cover
(☞ P.2-42 "[C] Top right cover").
- (2) Remove 2 screws to take off the right upper cover.

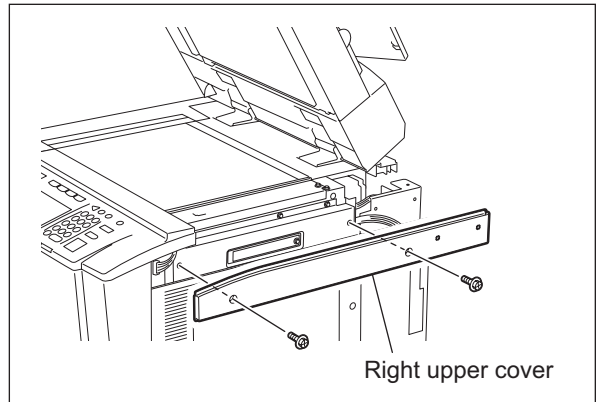

Fig. 2-37

[G] Right center cover

- (1) Open the bypass tray.
- (2) Remove 8 screws to take off the right center cover.

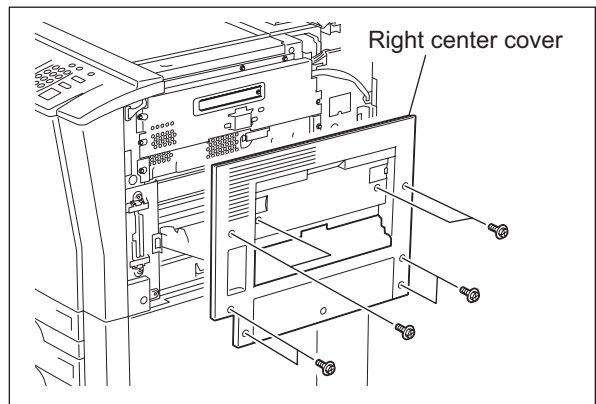

Fig. 2-38

[H] Right rear cover

- (1) Remove 2 screws and take off the right rear cover.

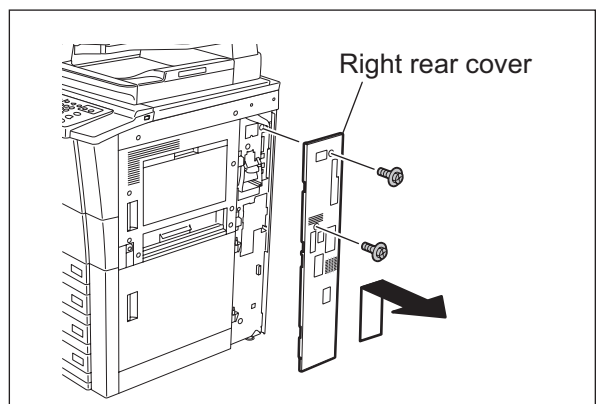



Fig. 2-39

[I] Left upper cover

- (1) Take off the top left cover
( P.2-42 "[D] Top left cover").
- (2) Remove 2 screws to take off the left upper cover.

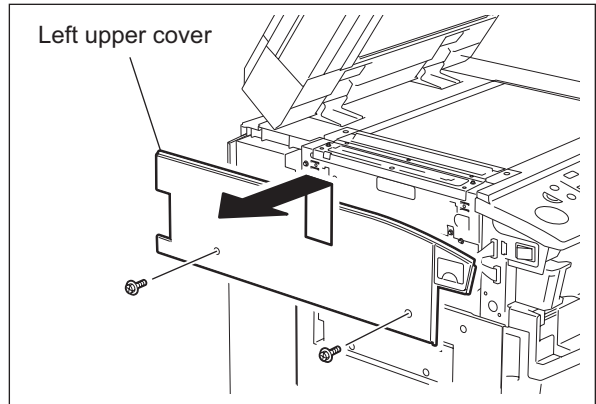

Fig. 2-40

[J] Left lower cover (Exit cover)

- (1) Remove 6 screws to take off the left lower cover.

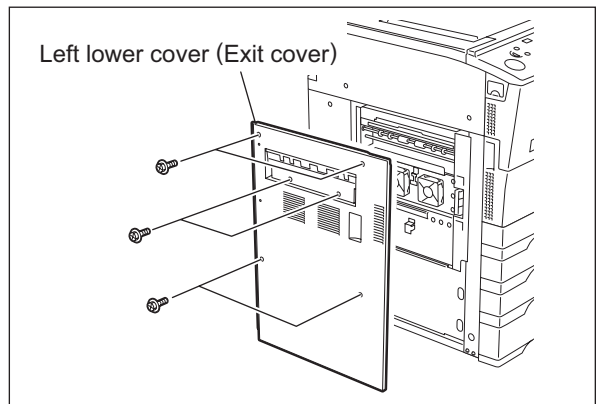

Fig. 2-41

[K] Left rear cover

- (1) Remove 1 screw to take off the left rear cover.

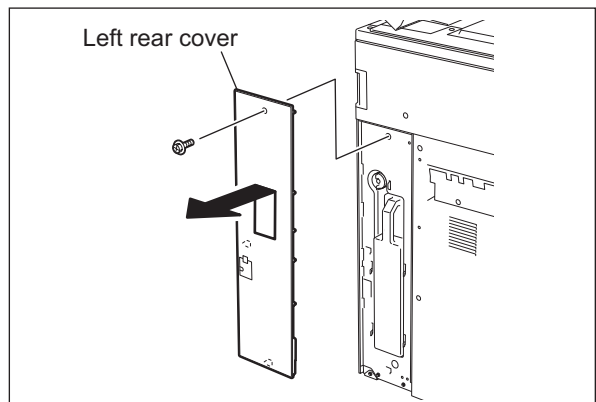

Fig. 2-42

[L] Rear cover

- (1) Loosen 1 screw fixing the ozone filter.
- (2) Remove 8 screws. Then release 2 hooks to take off the rear cover.

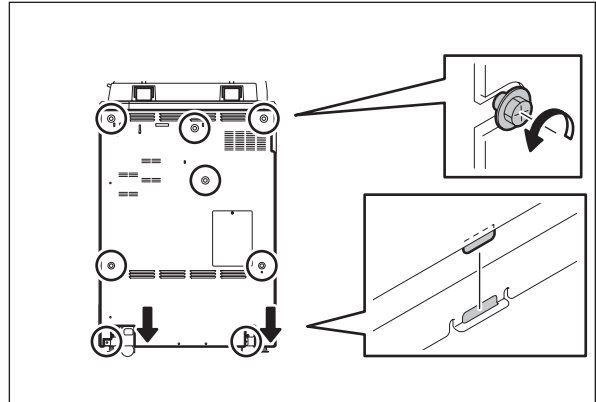

Fig. 2-43

2.6 Removal and Installation of Options

[A] Finisher

- (1) Press the [ON/OFF] button on the control panel to shut down the equipment.
- (2) Turn the power OFF using the main power switch on the right-hand surface of the equipment.
- (3) Unplug the power cable.
- (4) Take off the connector cover and unplug the interface cable.

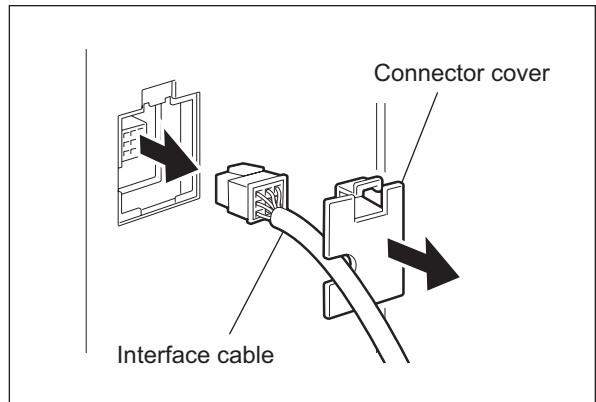

Fig. 2-44

- (5) Remove 1 screw and take off the finisher from the slide rail.

Note:

When moving the finisher unit by itself, be careful that it does not topple over.

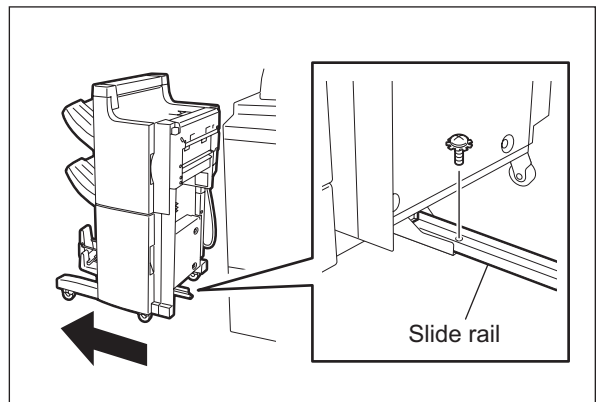

Fig. 2-45

[B] Large Capacity Feeder (LCF)

- (1) Press the [ON/OFF] button on the control panel to shut down the equipment.
- (2) Turn the power OFF using the main power switch on the right-hand surface of the equipment.
- (3) Unplug the power cable.
- (4) Press the button to separate the Large Capacity Feeder (LCF) from the equipment.

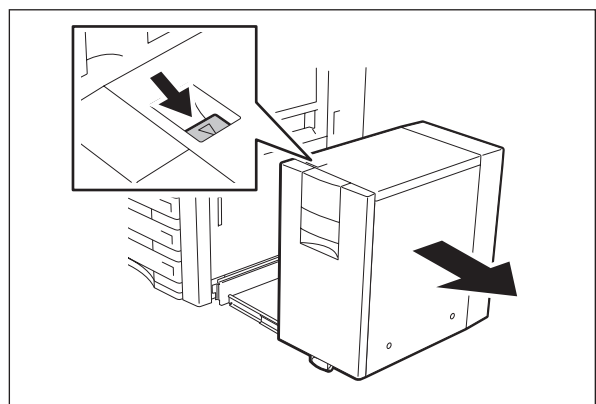

Fig. 2-46

- (5) Remove 1 screw and take off the connector cover.

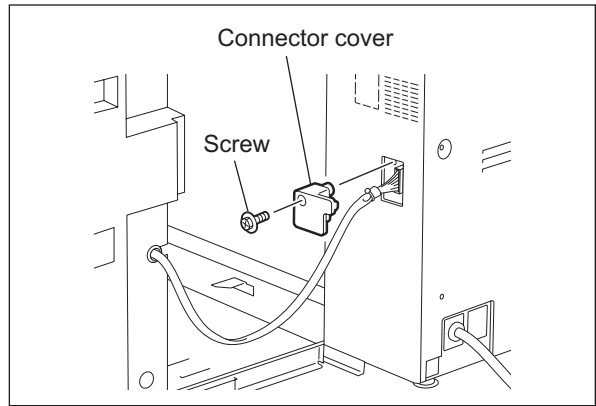

Fig. 2-47

- (6) Disconnect the interface cable of the Large Capacity Feeder (LCF).

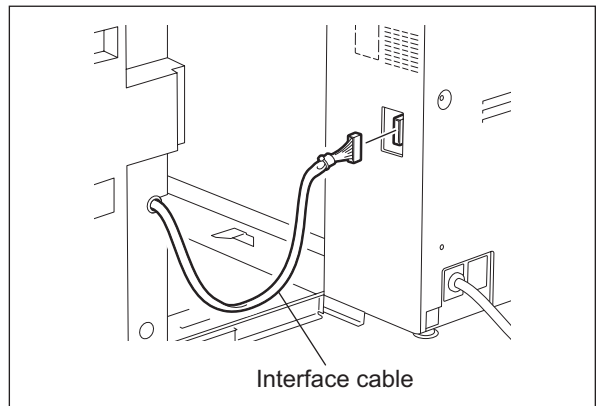

Fig. 2-48

- (7) Remove 2 fixing screws on the rear side.

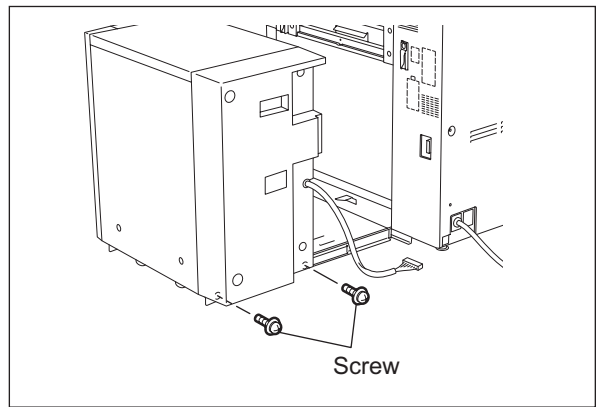

Fig. 2-49

- (8) Remove 2 fixing screws on the front side.

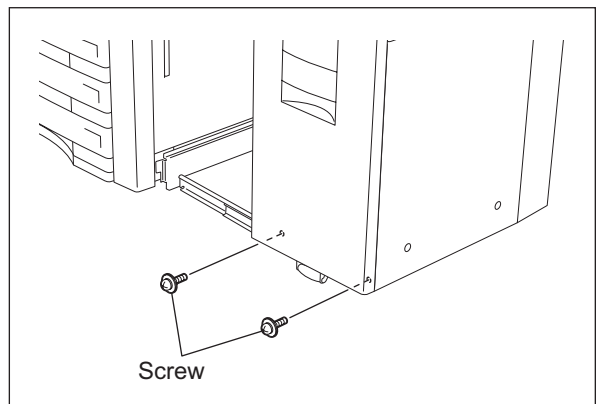

Fig. 2-50

- (9) Lift the Large Capacity Feeder (LCF) and take it off from the slide rail.

Note:

Be careful when lifting the Large Capacity Feeder (LCF) because it is heavy.

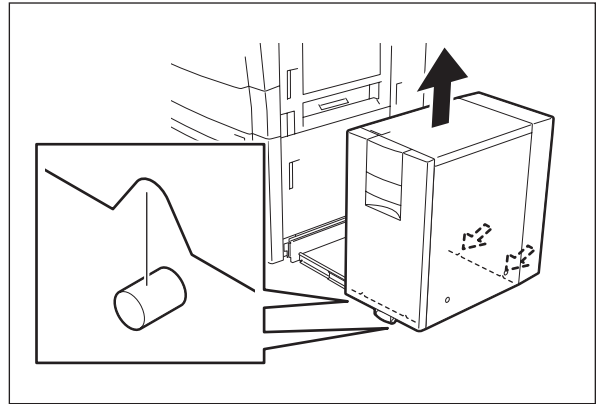

Fig. 2-51

3. COPY PROCESS

3.1 General Description

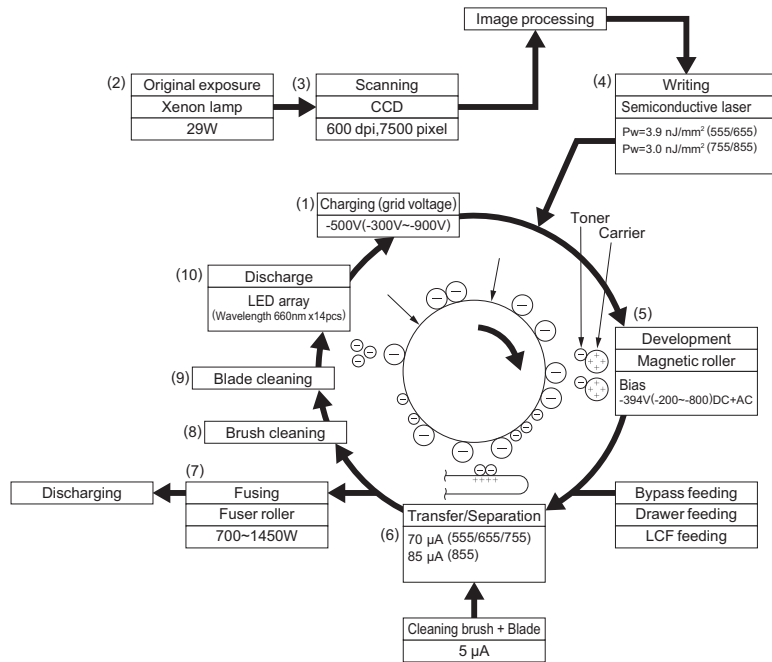

Fig. 3-1

- | | |
|--|--|
| <p>(1) Charging:
Negatively charges the surface of the photoconductive drum.</p> <p style="text-align: center;">↓</p> <p>(2) Original exposure:
Converts images on the original into optical signals.</p> <p style="text-align: center;">↓</p> <p>(3) Scanning:
Converts image optical signals into electrical signals.</p> <p style="text-align: center;">↓</p> <p>(4) Writing:
Converts image electrical signals into optical signals (laser emission) and exposes them to the surface of the photoconductive drum.</p> <p style="text-align: center;">↓</p> <p>(5) Development:
Makes the negatively-charged toner adhere to the photoconductive drum and forms a visible image.</p> <p style="text-align: center;">↓</p> | <p>(6) Transfer:
Transfers the visible image on the photoconductive drum onto paper.
Separation:
Separates the paper from the drum together with the toner.</p> <p style="text-align: center;">↓</p> <p>(7) Fusing:
Fuses the toner onto the paper by applying heat and pressure.</p> <p style="text-align: center;">↓</p> <p>(8) Brush cleaning:
Cleans dirt and paper dust on the drum.</p> <p style="text-align: center;">↓</p> <p>(9) Blade cleaning:
Forcibly removes the residual toner on the drum.</p> <p style="text-align: center;">↓</p> <p>(10) Discharging:
Discharges any remaining negative charge on the drum.</p> |
|--|--|

3.2 Details of Copy Process

(1) Photoconductive drum

The photoconductive drum consists of two layers, an outer and an inner layer. The outer layer is a photoconductive layer made of an organic photoconductive carrier (OPC). The inner layer is an aluminum conductive base in a cylindrical form. The photoconductive carrier has the characteristic that its electrical resistance changes depending on the strength of the light exposed.

Example:

- Strong light
Resistance is decreased (works as a conductor.)
- Weak light
Resistance is increased (works as an insulator.)

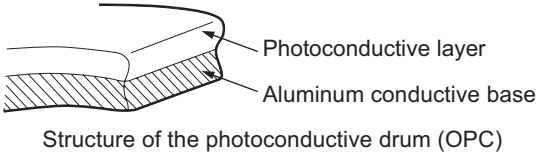
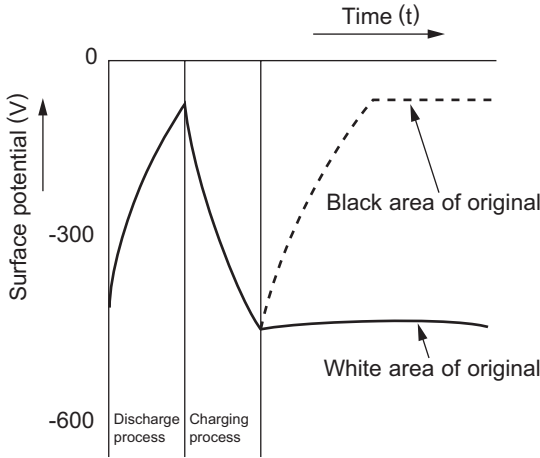

Fig. 3-2

[Formation of electrostatic latent image]

In the processes of charging, scanning, printing and discharging described later, negative potential on the areas of the drum corresponding to black areas of the original is eliminated, while the areas of the drum corresponding to white areas remains the negative charge. As this image on the drum formed by the negative potential is invisible, it is called an “electrostatic latent image”.



Electric potential on the photoconductive drum

Fig. 3-3

(2) Charging

Charging is a process of applying a charge uniformly to the photoconductive drum surface. The charger wire produces a negative corona discharge, which is controlled by the grid so that the drum surface is uniformly charged with negative potential. The surface potential on the drum is determined by the grid potential and controlled to a certain value by the grid control circuit.

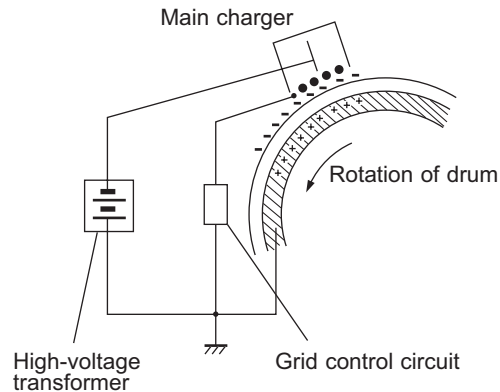

Fig. 3-4

(3) Scanning

Scanning is a process of exposing the original to the light and converting the reflection into electrical signals. The light reflected from the original is imported to the charge coupled device (CCD) and this optical image information is converted into electrical signals (image signals), which are then sent to the image processing section.

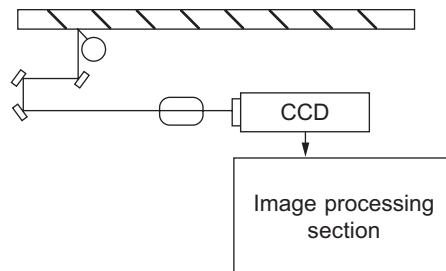

Fig. 3-5

(Example)

CCD light receiving amount	Value of image signals to be output
Light	255
Dark	0

} Difference between "light" and "dark" is divided into 256 steps.

Fig. 3-6

(4) Writing

Writing is a process of converting the image signals sent from the image processing section into optical signals and exposing the drum surface to the light.
Semiconductor laser element converts image signals sent from the image processing section into optical signals (laser emission) and exposes the drum surface to the light to form an electrostatic latent image on it.

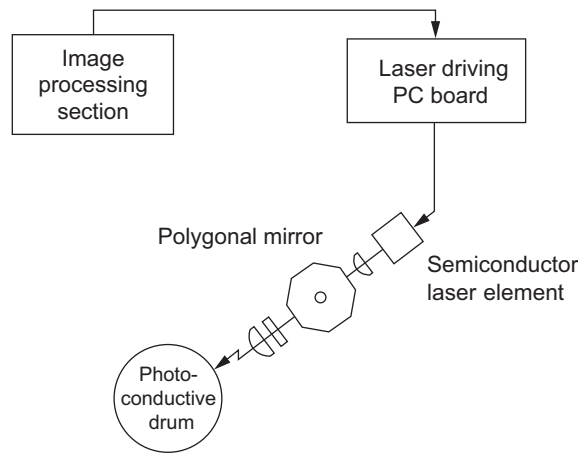

Fig. 3-7

(5) Development

Development is a process of making the electrostatic latent images visible to the eye (visible images).
Developer material is supplied to the photoconductive drum surface by magnetic roller. The toner in the developer material adheres to the areas on the drum surface where the potential is lower than the developer bias which is applied to the magnetic roller (reverse development method).

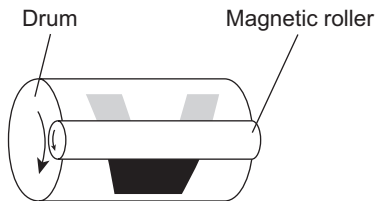

Fig. 3-8

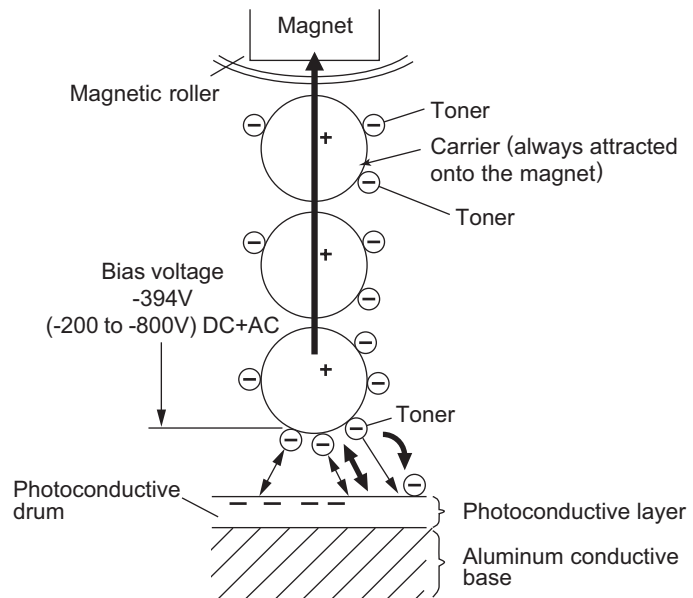

Fig. 3-9

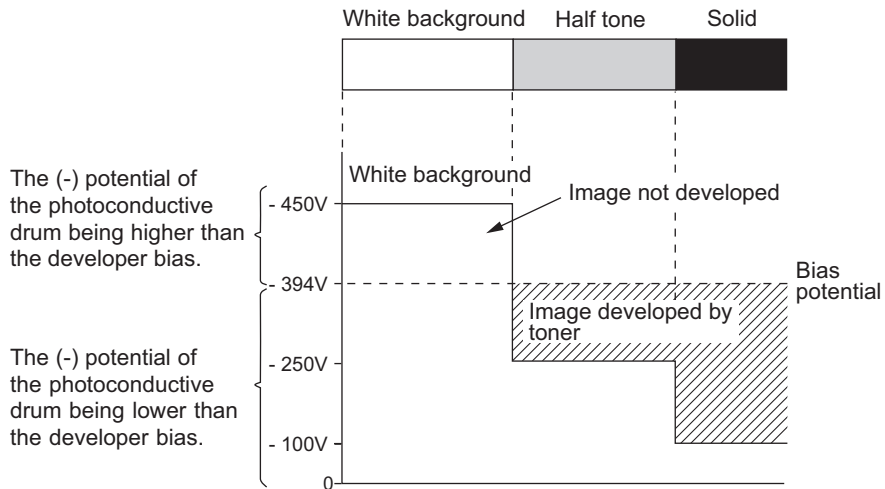

Fig. 3-10

- Developer material
 The developer material is a mixture of toner and carrier. The toner is charged to negative polarity and the carrier to positive polarity, due to the friction with each other caused by mixing.
 Toner: Mainly consists of resin and carbon.
 Carrier: Consists of ferrite and resin coating on its surface to provide consistent frictional electrification.

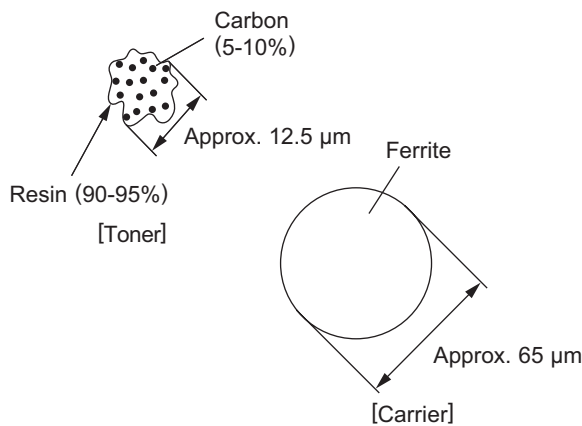

Fig. 3-11

Note:

If the developer material is used for a long time (beyond its normal life span), the toner is caked onto the carrier.

↓
 The carrier's (charging) performance is lowered.

Symptom:

1. Image density is decreased.
2. Toner scattering occurs.
3. Background fogging occurs.

Solution:

Replace new developer material.

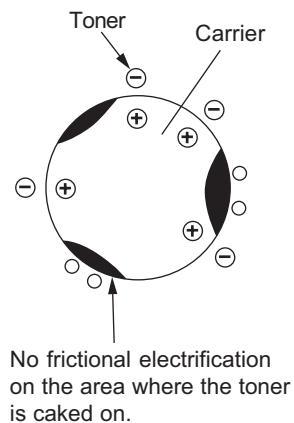

Fig. 3-12

- Magnetic roller
 - Magnetic brush development -
The south and north poles are arranged inside the magnetic rollers, as shown in the following figure.
The developer material forms a brush-like fluff which contacts the photoconductive drum surface
↓
This is caused by the lines of magnetic force between the south and north poles.

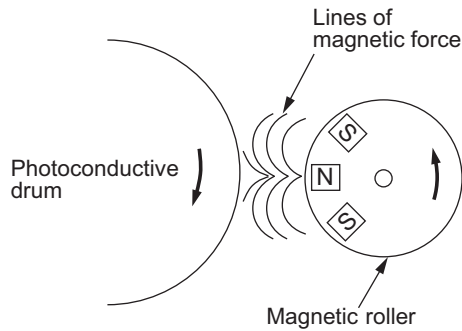

Fig. 3-13

- Additional Explanation
The life of the toner cartridge (number of copies) varies depending on the following conditions.
 1. Coverage of originals (printing image ratio of the original size) and density of original background
 2. Size and density of originals
 3. The existence of solid black when making copies (when a book is copied and the original cover is partially open)
 4. Temperature and humidity in the room when making copies
 5. Copy density and image quality mode
 As indicated in the figure below, the life of the toner cartridge varies depending on the copy mode and coverage of originals

A full block in the figure below denotes approx. 10,000 copies.

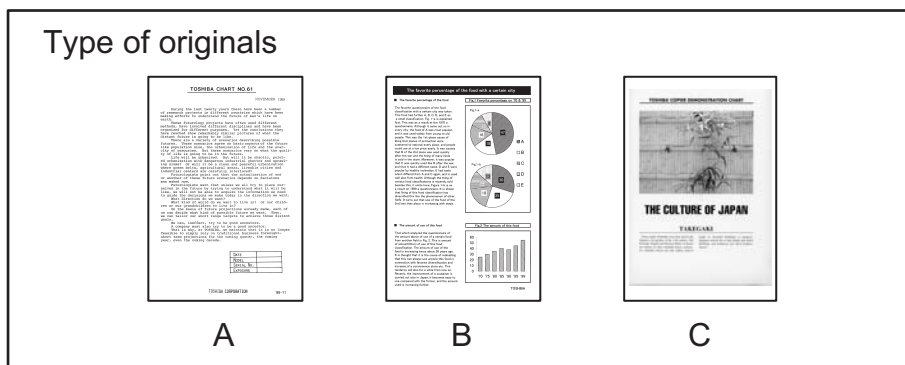
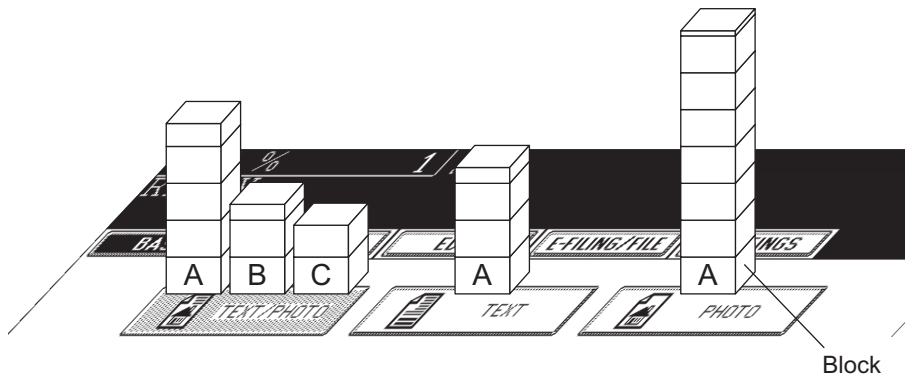

Fig. 3-14

(6) Transfer/Separation

Transfer:

Transfer is a process of transferring the toner image (visible image) formed on the drum surface onto the paper.

An electric charge applied by the high voltage power supply flows to the transfer belt from the power supply roller. Then it flows to the paper and photo conductor. The toner, which has been developed on the photo conductor, is transferred to this paper with an electric charge.

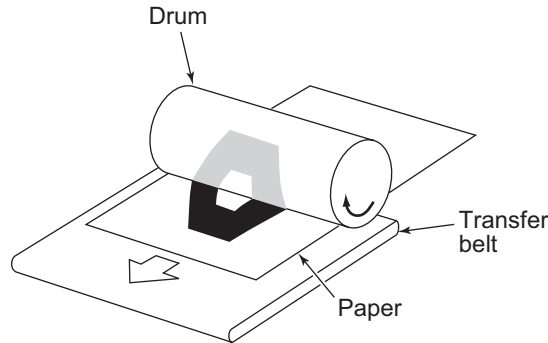

Fig. 3-15

Separation:

The paper is absorbed to the belt and separated from the drum by the electrostatic attraction acting between the belt (plus charge) and the polarization charge (minus charge) on the bottom surface of the paper.

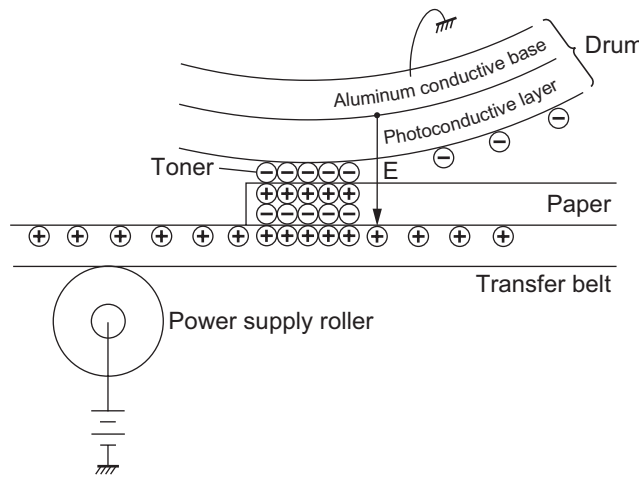

Fig. 3-16

Reference

- Combined use of transfer belt and separation finger
To prevent the copy paper from failing to be separated during the operation, due to incomplete transfer belt charging or absorption of moisture, and thus jamming up the cleaner, a separation finger mechanically separates any copy paper which fails to be separated.

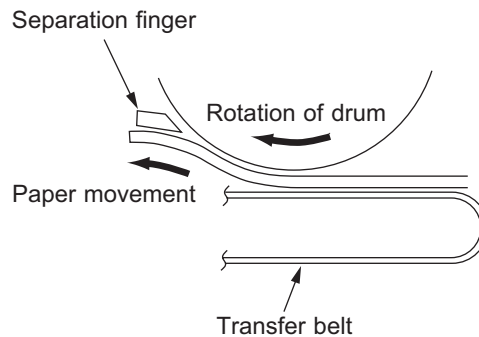

Fig. 3-17

(7) Fusing

Fusing is a process of melting and fixing the toner on the paper.

Method:

The softening point of the toner (main ingredient: resin) is 90 to 100°C.



(Heat)

The toner is melted by the heat of the surface of the fuser roller.



(Pressure)

The pressure roller is pressed against the fuser roller by the springs to increase adherence of the melted toner to the paper.



Heat and pressure are applied to the paper when it passes between the fuser roller and pressure roller.



(Fusing)

The toner is fixed on the paper.

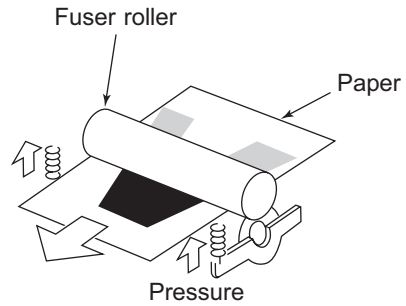

Fig. 3-18

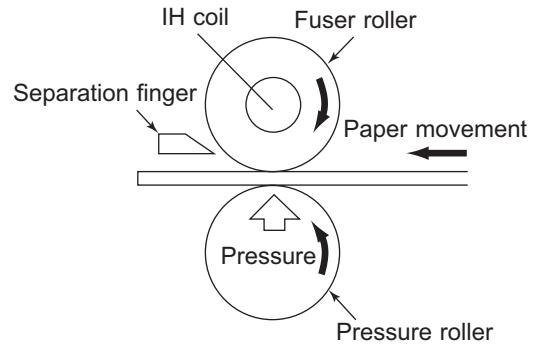

Fig. 3-19

(8) Cleaning

Cleaning is a process of recovering the residual toner on the photoconductive drum.

1. The cleaning brush scrapes off the excessive toner and paper wastes. The flicker scrapes off the toner on the brush.
Also, too prevent the cleaning blade from scratching the surface of the drum to make a circumferential streak, the varistor is attached between the brush and earth.
2. Cleaning blade scrapes off the residual toner on the drum.
3. The recovery blade picks up the scraped toner.

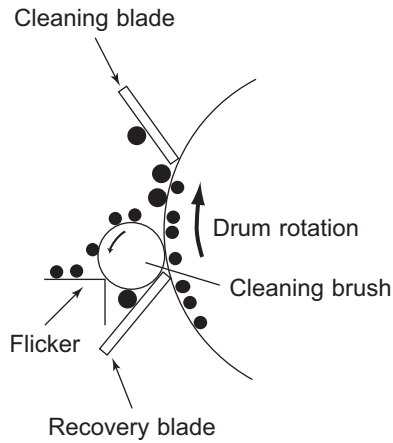

Fig. 3-20

(9) Discharging

Discharging is a process of eliminating the (-) charge remaining on the photoconductive drum before the next charging process begins.

If discharging does not occur, the following phenomenon will occur:

The (-) charge remains on the photoconductive drum.



Uneven charge is applied to the drum during the next copy.



The next copy has a double image.

(Preceding image appears.)

Solution:

Expose the entire surface of the photoconductive drum to the light by the discharge LED array.



The photoconductive drum becomes electrically conductive.



All the (-) charges remaining on the photoconductive drum are conducted to the ground.



The preparation for the next copy is completed.

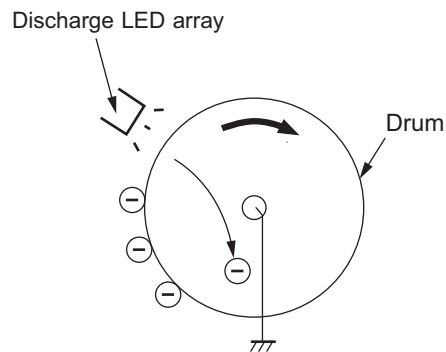

Fig. 3-21

3.3 Comparison of Copy Process to e-STUDIO550/650/810

Process	e-STUDIO550/650/810	e-STUDIO555/655/755/855
1. Photoconductive drum • Sensitivity • Surface potential	OD-6510 (OPC drum) Highly sensitized drum -700 V (grid voltage -733 V)	← ← -490 V (-290 to -890 V) Grid voltage -500 V (-300 to -900 V)
2. Charging	Scolotron method (constant current) Grid output variable	← ←
3. Surface potential controlling	Surface potential sensor	←
4. Writing • Light source • Light amount	Semiconductor laser (adjustment not required) 3.8 nJ/mm ²	← 3.9 nJ/mm ² (e-STUDIO555/655) 3.0 nJ/mm ² (e-STUDIO755/855)
5. Image density control	Image quality sensor	←
6. Development • Magnetic roller • Auto-toner • Toner supply • Toner-empty detection • Toner • Developer material • Developer bias	Two magnetic rollers Magnetic bridge-circuit method Toner cartridge system (There is a toner recycle system.) Density detection system T-6510/6510E/6510D D-6510 DC-500V + AC	← ← ← ← (There is a toner cartridge empty detecting system by piezoelectric type sensor.) PS-ZT8550/PS-ZT8550E/ PS-ZT6000D/PS-ZT6000C PS-ZD6000 -394 V (-200 to -800 V) DC + AC
7. Transfer • Transfer • Power supply roller Separation auxiliary roller	Transfer belt Power supply roller none	← ← ←
8. Separation	Transfer belt charging Separation finger applied	← ←
9. Discharging • Discharging position • Discharge lamp • Pre-cleaning discharge	Discharge by exposure after cleaning Discharge by red LED None	← ← ←
10. Cleaning • System • Recovered toner	Blade + Brush Reuse (by the toner recycle system)	← ←
11. Cleaning brush bias	Varistor 430V	←
12. Fusing • System • Cleaning • Heater	Long-life heat roller system Fuser roller: Fluoroplastic-coated roller (ø60) Pressure roller: PFA tube roller (550/610:ø50, 810:ø60) Cleaning web (for fuser roller cleaning) Pressure roller cleaning felt roller Pressure roller cleaning metal roller IH coil (Induction heating system) ON/OFF control by thermistor	← ← Pressure roller: PFA tube roller (ø60) ← none none ← ←

4. GENERAL OPERATION

4.1 Overview of Operation

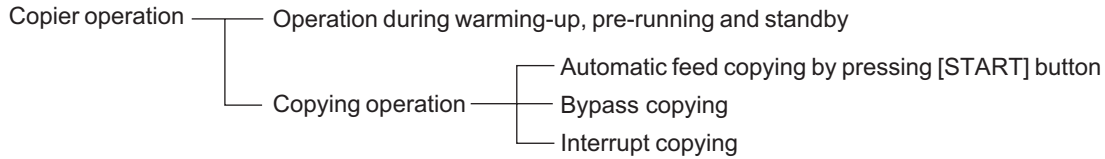

4.2 Description of Operation

4.2.1 Warming-up

1. Initialization

Turning the power ON

- The IH coil is turned ON.
- The set number "1" reproduction ratio "100%" and "WAIT WARMING UP" appears.
- The fan motors are turned ON.
- Initialization of the scanning system
 - The carriage moves to the home position and stops.
 - The carriage moves to the peak detection position.
 - The exposure lamp (EXP) is turned ON.
 - Peak detection (a white color is detected by the shading correction plate)
 - The exposure lamp (EXP) is turned OFF.
 - The carriage moves to the home position.
- Initialization of the feeding system
 - Each drawer tray goes up
- Initialization of the writing system
 - The polygonal motor (M2) rotates at a high speed. (e-STUDIO755/855)
 - The polygonal motor (M2) rotates at a low speed. (e-STUDIO555/655)
 - The beam position is controlled. (e-STUDIO755/855)
- Other
 - The main charger cleaner operates.

2. Pre-running operation

The pre-running operation starts when the temperature of the fuser roller surface reaches a certain degree. (Pre-running is not performed when the fuser roller is already hot enough.)

- The fuser motor (M3) is turned ON.
 - The fuser roller rotates.
- The drum motor (M11) is turned ON.
 - The drum rotates.
- The used toner transport motor (M9) is turned ON
 - The used toner transport auger rotates.
- Image quality control
 - It charges the drum and detects the drum surface potential to set the optimal condition for outputting the image.
 - It forms a patch on the drum and reads out its reflective ratio to set the optimal condition.

3. When the surface temperature of the fuser roller becomes sufficient for fusing;

- The IH coil (IH-COIL) is turned OFF.
- The set number "1" and "READY" are displayed.

4.2.2 Ready state (ready for copying)

The buttons on the control panel are enabled.

→ When no button is pressed for a certain period of time;

- The set number "1" and reproduction ratio "100%" are displayed. The equipment returns to the normal ready state.

4.2.3 Drawer feed copying with the [START] button

1. Pressing the [START] button

→ "READY" changes to "COPYING".

→ The exposure lamp (EXP) is turned ON.

→ The scan motor (M1) is turned ON. → Carriage-1 and -2 move forward.

→ The polygonal motor (M2) rotates at a high speed (the e-STUDIO755/855 is always at a high speed).

→ Each motor is turned ON. → The drum, transfer belt, fuser unit and developer unit rotate.

→ The main charger, developer bias and discharge LED (ERS) are turned ON. The fans rotate at a high speed.

2. Drawer paper feeding

→ Each motor is turned ON. The drum, transfer belt, fuser unit and developer unit rotate.

→ The main charger, developer bias and discharge LED (ERS) are turned ON. The fans rotate at a high speed.

→ The feed motor (M20), drawer feed clutch (CLT6, 8, 10, 12) and drawer transport clutch (CLT5, 7, 9, 11) are turned ON.

→ The pickup roller, feed roller and transport roller start to rotate.

- The paper reaches the transport roller.

- The drawer transport sensor (S33, 39, 45, 51) is turned ON.

→ The drawer feed clutch (CLT6, 8, 10, 12) and drawer transport clutch (CLT5, 7, 9, 11) are turned OFF after a certain period of time.

- The paper reaches the intermediate transfer roller.

- The paper reaches the registration roller.

- The registration sensor (S18) is turned ON and aligning is performed.

3. Carriage operation:

Scan motor (M1) ON

→ The exposure lamp (EXP) is turned ON. → White shading compensation is performed.

→ The scan motor (M1) is turned ON. → Carriage-1 and -2 move forward.

4. Within a certain time after carriage operation:

→ The registration motor (M16) is turned ON. → The paper is transported to the transfer area.

→ The copy counter operates.

5. Within a certain time after the registration motor (M16) is turned ON, the transfer belt bias is turned ON.

6. Completion of scanning

→ The scan motor (M1) is turned OFF.

→ The exposure lamp (EXP) is turned OFF.

→ The registration motor (M16) is turned OFF (after the trailing edge of the paper passes the registration roller).

7. Paper exit

- The exit sensor (S22) detects the trailing edge of the paper.
- The equipment enters the toner supply operation when developer material toner density is lower than the preset value.
- The main charger, developer bias and discharge LED (ERS) are turned OFF.
- The drum, transfer belt, fuser unit and developer unit stop. Each fan returns to the ready rotation.
- The feed motor (M20) is turned OFF.
- The rotation speed of the polygonal motor (M2) switches from a high speed to a low speed.
(e-STUDIO555/655)
- "READY" appears and the equipment enters the ready state.

Timing chart for copying one A4 sized sheet fed from the 1st drawer
[e-STUDIO555/655]

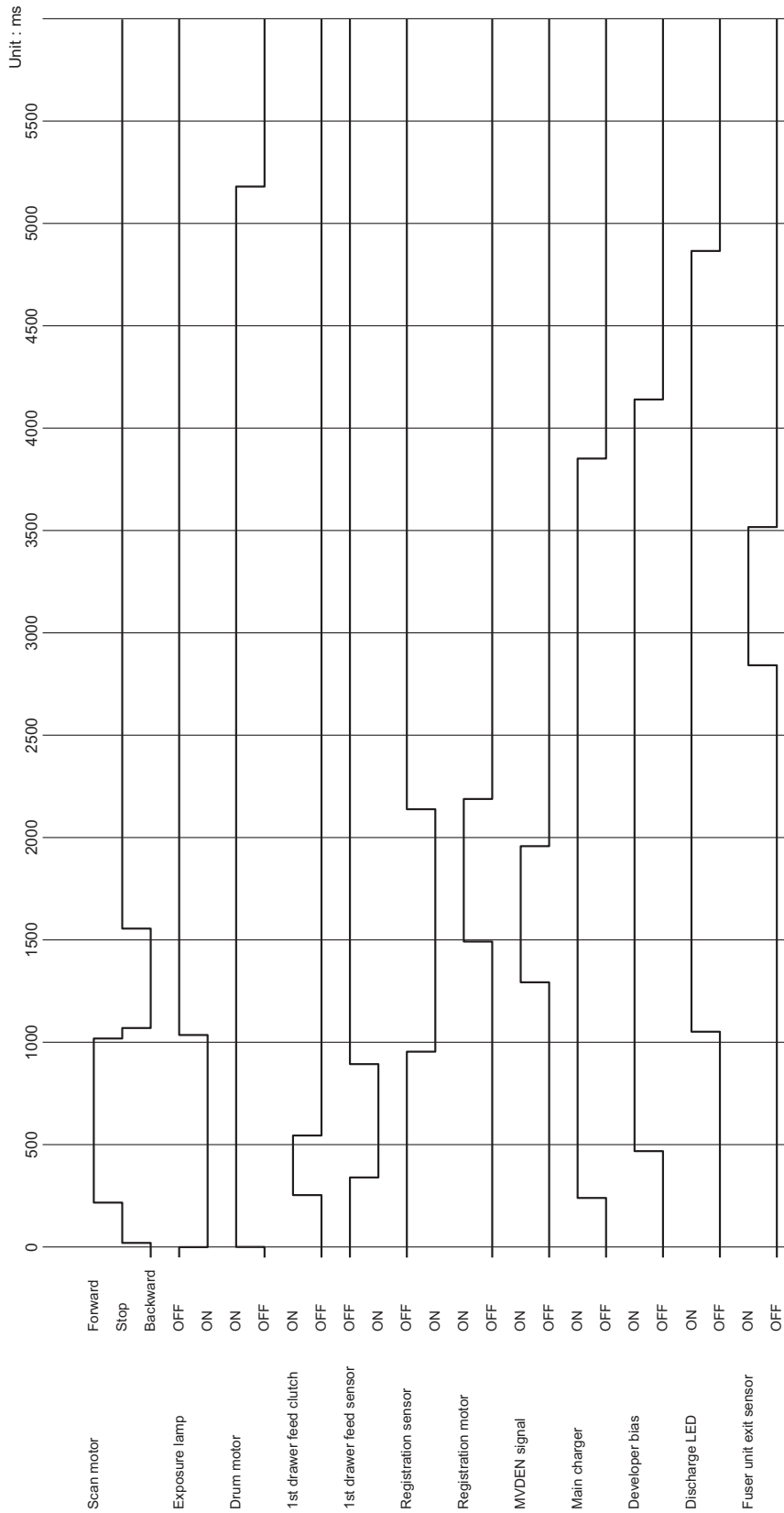

Fig. 4-1

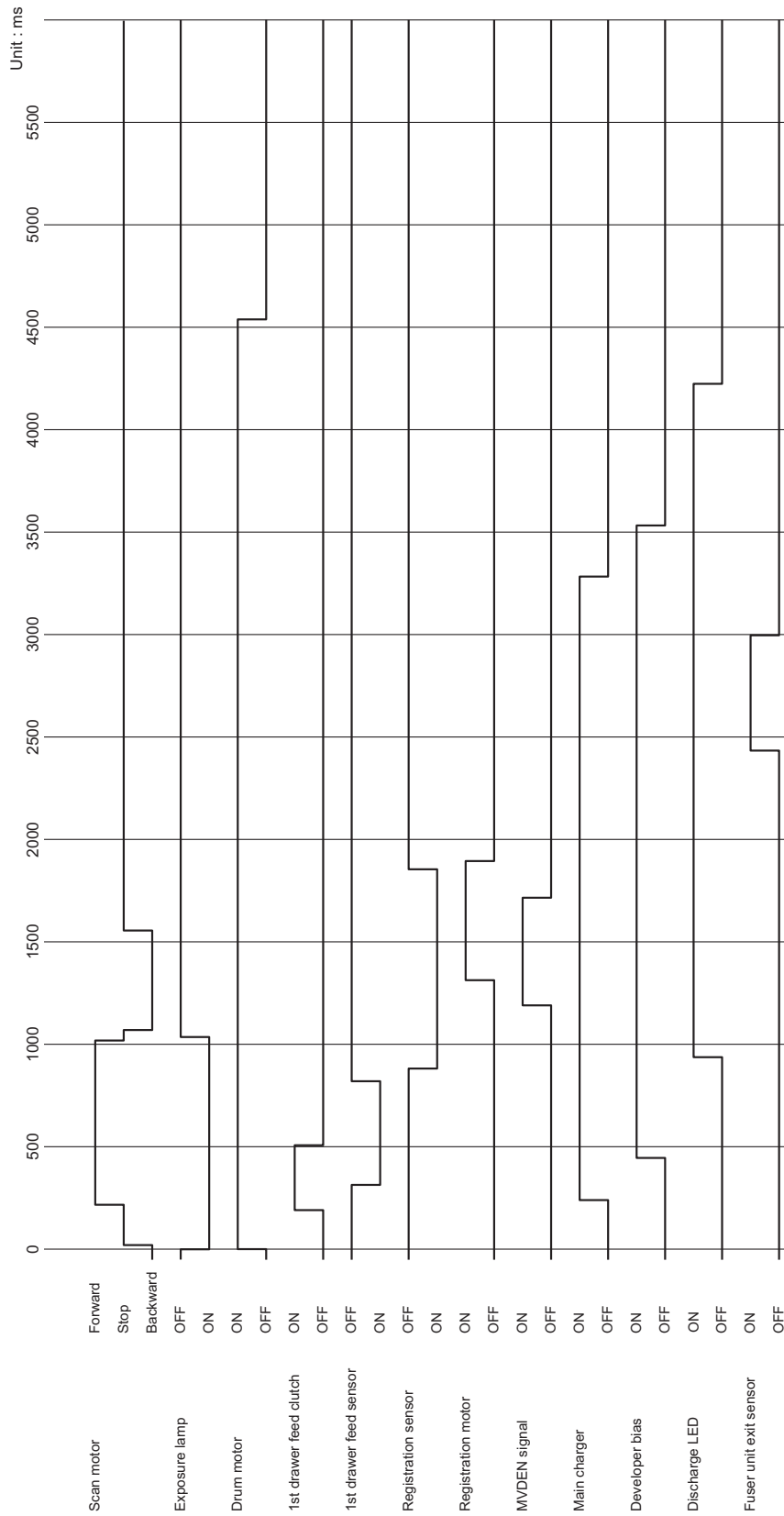

Fig. 4-2

4.2.4 Bypass feed copying

1. A sheet of paper is inserted into the bypass tray.
 - The bypass feed sensor (S27) is turned ON. → "Set media type" appears.
 - Select the media type and paper size. → "Ready for bypass feeding" appears.

2. Pressing the [START] button
 - "Ready for bypass feeding" changes to "COPYING".
 - The drum, developer unit, transfer belt and fuser roller rotate.
 - The main charger, developer bias and discharge LED (ERS) are turned ON. Each fan rotates at a high speed.

3. Bypass feeding
 - The bypass pickup solenoid (SOL3) is turned ON. The feed motor (M20) is turned ON.
 - The bypass pickup roller is lowered.
 - The bypass feed clutch (CLT4) is turned ON.
 - The bypass pickup roller and bypass feed roller start to rotate.
 - Aligning operation
 - The paper reaches the registration roller.
 - After a certain period of time, the bypass pickup solenoid (SOL3) and bypass feed clutch (CLT4) are turned OFF.

4. Hereafter, the operation 3) to 6) of "4.2.3 Drawer feed copying with [START] button" is repeated.

4.2.5 Interruption copying

1. Pressing the [INTERRUPT] button
 - The LED "INTERRUPT" is turned ON.
 - The copying operation in progress stops temporarily. Carriage-1 and -2 return to their appropriate positions.
 - "Job interrupted job 1 saved" appears.
 - The automatic density and reproduction ratio 100% are set. (The set number remains the same.)

2. Selecting the desired copy conditions

3. After interruption copying is finished:
 - When the LED "INTERRUPT" is turned OFF by pressing the [INTERRUPT] button, the equipment returns to the status before the interruption.
 - "Ready to resume job 1" appears.

4. Pressing the [START] button
 - The copying operation before the interruption resumes.

4.3 Detection of Abnormality

When something abnormal has occurred in the equipment, the symbols corresponding to the type of abnormality are displayed.

4.3.1 Types of abnormality

1. Abnormality which can be cleared without turning OFF the door switch
 - (A) Adding paper
 - (B) Pick-up failure in the bypass
2. Abnormality which cannot be cleared without turning OFF the door switch
 - (C) Misfeeding in the equipment
 - (D) The developer unit is not installed properly.
 - (E) Replacing the toner cartridge
3. Abnormality not cleared without turning OFF the main switch
 - (F) Replacing the toner bag
 - (G) Call for service

4.3.2 Description of abnormality

(A) Adding paper

- The drawer empty sensor (S31, 37, 43, 49) detects the presence or absence of paper.

[When the drawer is not installed]

No drawer is detected.



The tray does not go up (the drawer empty sensor (S31, 37, 43, 49) is turned OFF).



"Add paper" appears.



The [START] button is disabled.

[When the drawer is installed]

The drawer is detected.



Tray goes up (the drawer empty sensor (S31, 37, 43, 49) is turned OFF).



"Add paper" appears.



The [START] button is disabled.

- When the power is turned ON or the feed unit performs initialization.



Detecting the presence of paper

- The tray-up motor (M21, 22) is turned ON. → The tray goes up.

→ When the drawer tray-up sensor (S32, 38, 44, 50) is not turned ON within a fixed period of time, it means that the tray is in an abnormal condition. → "Add paper" appears regardless of whether paper is on the tray or not.

- It is cleared by turning the power ON/OFF.

→ The drawer tray-up sensor (S32, 38, 44, 50) is turned ON within a fixed period of time.

→ The tray-up motor (M21, 22) stops.

- At this time, if the drawer empty sensor (S31, 37, 43, 49) is ON: It is judged that there is paper
OFF: It is judged that there is no

paper.



The drawer area of the LCD panel blinks (when the drawer is selected).

- Paper in the drawer runs out during copying.



The drawer tray-up sensor (S32, 38, 44, 50) is turned OFF



The tray-up motor (M21, 22) is turned ON → The tray goes up.



The drawer tray-up sensor (S32, 38, 44, 50) is turned ON → The tray-up motor (M21, 22) stops.

- The drawer empty sensor (S31, 37, 43, 49) is turned OFF during the copying although the drawer tray-up sensor (S32, 38, 44, 50) is ON.



It is judged that there is no paper.



The drawer area of the LCD panel blinks (when the drawer is selected).



The copying operation stops.

(B) Pick-up failure in bypass

- During bypass feeding

The bypass pickup solenoid (SOL3) is turned ON.



The registration sensor (S18) is turned ON.

→ The registration sensor (S18) is not turned ON within a fixed period of time.



Pick-up failure in bypass



The clear paper symbol is displayed: E120



Copying operation is disabled.



Solution: Remove the paper from the bypass tray. → The bypass paper sensor (S27) is turned OFF.

(C) Misfeeding in equipment

- The fuser transport sensor (S9) detects jamming of the leading edge of the paper.
The registration motor (M16) is turned ON.
↓
The fuser transport sensor (S9) is not turned ON within a fixed period of time.
↓
Paper jam (E010) → The copying operation stops.
- The fuser transport sensor (S9) detects jamming of the trailing edge of paper.
The registration motor (M16) is turned OFF.
↓
The fuser transport sensor (S9) is not turned OFF after a fixed period of time.
↓
Paper jam (E020) → The copying operation stops.
- Immediately after the power is turned ON;
↓
Any of the sensors on the paper transport path detects the paper (ON).
↓
Paper jam (E030)
- The front cover (lower) opens during copying.
↓
Paper jam (E410)
- The registration sensor (S18) detects jamming of the leading edge of the paper:
The registration sensor (S18) is not turned ON within a fixed period of time after the leading edge of paper passes the transport roller.
↓
Paper jam (E200, E210, E300, E330, E260, E110 and E3C0)
- The intermediate transport sensor (S17) detects jamming of the leading edge of the paper:
The intermediate transport sensor is not turned ON within a fixed period of time after the leading edge of paper passes the 1st drawer transport sensor (S33).
↓
Paper jam (E201, E211, E301, E331, E3C1, E261 and E2A1)
- Each drawer transport sensor (S33, 39, 45, 51) detects jamming of the leading edge of the paper:
The transport sensors (S33, 39, 45, 51) are not turned ON within a fixed period of time after the leading edge of the paper passes each drawer feed sensors (S34, 40, 46, 52).
↓
Paper jam (E230, E240, E250, E370, E380, E3F0)
- When a sheet of reversed paper is transported, horizontal transport sensor-1, -2 (S19, 20) or reverse sensor-1 (S23) does not detect paper within a fixed period of time.
↓
Paper jam (E511, E512, E540)

- When a sheet of paper is fed, the feed sensor (S34, 40, 46, 52) is not turned ON after the feed clutch (CLT6, 8, 10, 12) is turned ON.



Paper jam (E130, E140, E150, E160, E180, E190: The error codes change depending on the drawer used.)

(D) The developer unit is not installed properly.

Disconnecting the connectors of the developer unit



"Developer unit not installed" appears.

Solution: Connect the connectors of the developer unit and close the front cover (lower).

(E) Replacing the toner cartridge

The toner cartridge empty sensor (S10) detects that there is no more toner left in the cartridge.



Open the front cover (upper) and replace the toner cartridge.



↓ (The toner cartridge is not replaced.)



The toner density becomes low.



The auto-toner sensor (S12) detects that there is no more toner left in the cartridge.



Control circuit → The copying operation is disabled.

Solution: Replace the toner cartridge with a new one.

(F) Replacing the toner bag

- The toner bag becomes full of used toner.



The used toner transport auger moves to the feed side: The toner bag full detection sensor (S11) is turned ON.



"Replace toner bag" appears.

Solution: Have your service engineer replace the toner bag with a new one and clear the value of 08-476 to 0.

- The toner bag full detection sensor (S11) is turned ON during copying.



The copying stops after the last sheet copied is discharged.

Solution: Have your service engineer replace the toner bag with a new one and clear the value of 08-476 to 0.

(G) Call for service

Check the error code displayed on the control panel when "Call for service" appears, and handle the abnormality in reference to the error code table in the Service Handbook.

5. CONTROL PANEL

5.1 General Description

The control panel consists of button switches and touch-panel switches to operate the equipment and select various modes, and LEDs and an LCD to display the state of the equipment or the messages. When the operator's attention is required, graphic symbols light or blink with messages explaining the condition of the equipment in the LCD panel. When paper jams and "Call for service" occur, error codes are also displayed to notify users of the problem.

A color LCD is used in this equipment so that visibility and operability are improved.

The [ON/OFF] button is placed on the control panel of this equipment. Use this button instead of the main power switch to turn ON/OFF the power.

Press the [ON/OFF] button for 1 second or more to turn ON/OFF the power of the equipment.

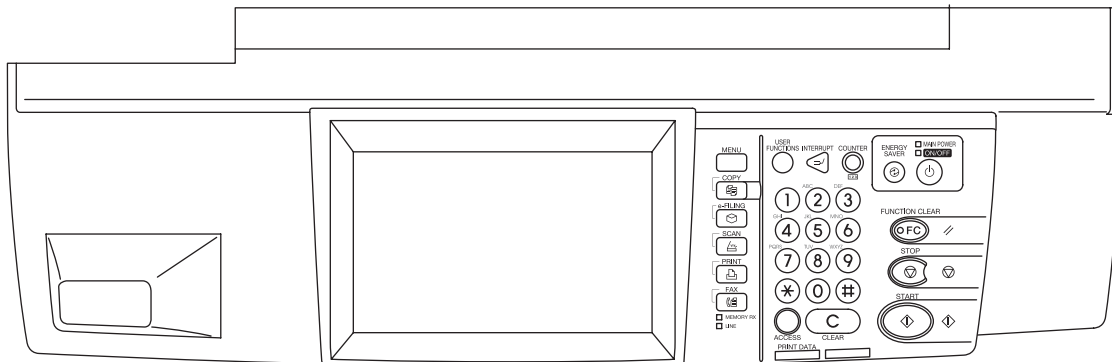

Fig. 5-1

5.2 Items Shown on the Display Panel

5.2.1 Display

1. Basic display
Displays buttons and messages.

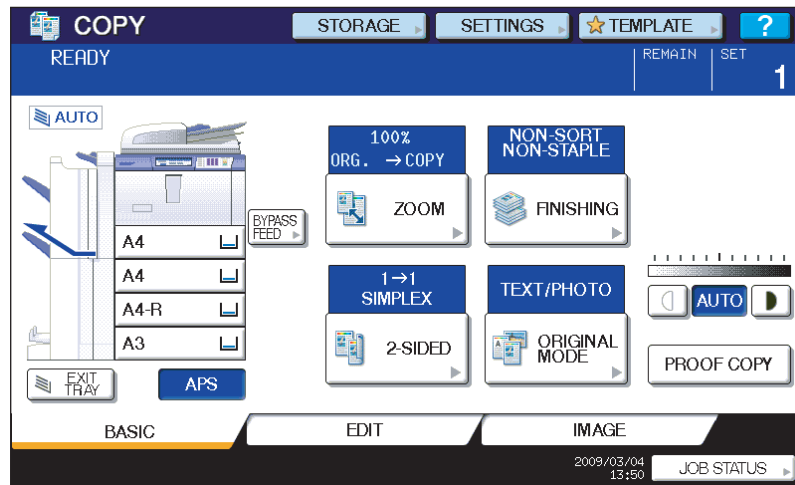

Fig. 5-2

2. Paper jam / service call display
Displays error code, paper jam position and paper jam release guidance, etc.

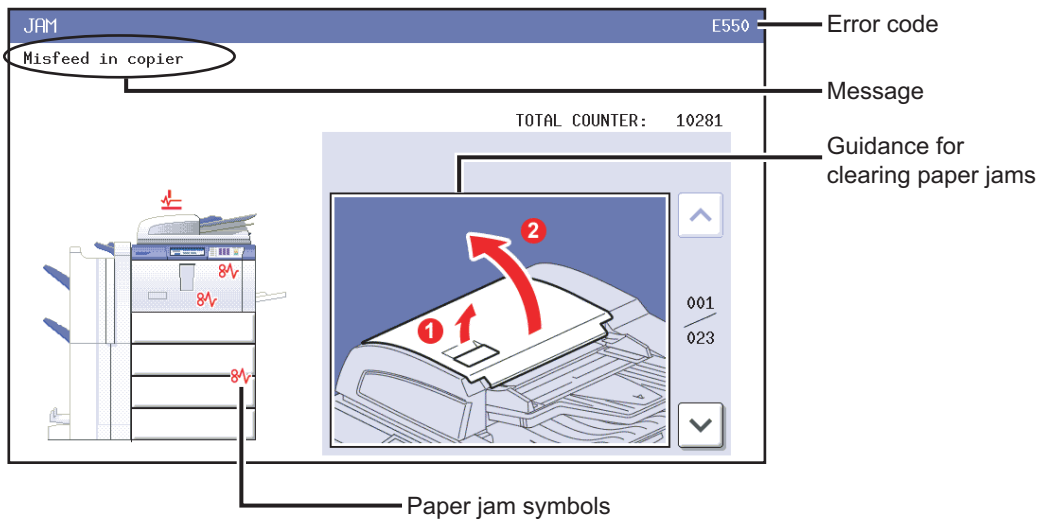

Fig. 5-3

5.2.2 Message

No.	Message	State of equipment	Note
1	-	Power is OFF (at Sleep Mode)	Press the [START] button or function button to clear
2	Saving energy - press START button	At Energy Saving Mode	Press the [START] button to clear
3	Wait Warming Up	Scanner warming up • Displayed until the equipment becomes ready to start scanning	Auto Start can be set
4	Wait Warming Up Auto Start	Scanner warming up • Displayed when Auto Start is set	Press the [STOP] button to clear the Auto Start.
5	WAIT	Displayed when performing the controlling function to keep the equipment at the best condition	
6	Wait adding toner	Supplying toner • Equipment becomes the toner supply state	Recovers when the toner supply has finished
7	Performing Auto Calibration	Displayed at image quality control	Recovers when the image quality control has finished
8	READY	Ready for copying • Waiting for the operation	
9	READY Press START button to copy	Copying job interrupted	Press the [START] button to resume copying or press [MEMORY CLEAR] button to delete the job
10	READY (WARMING UP)	Scanner warming up • Ready to scan the original	
11	READY (PRINTING)	Printing out the data • Scanning is enabled	
12	READY (ADDING TONER)	Supplying toner • Scanning is enabled	
13	READY (CHECK STAPLER)	No staples in finisher • Scanning is enabled	Cleared by supplying staples
14	READY (CHECK STAPLER)	Stapling jam occurred in finisher	
15	READY (CHECK SADDLE STITCH STAPLER)	No staples in saddle stitcher • Scanning is enabled	Cleared by supplying staples
16	READY (ADD PAPER) Press JOB STATUS button	No paper in drawer • Scanning is enabled	Cleared by supplying papers
17	READY (FINISHER FULL)	Finisher is full of paper • Scanning is enabled	Resumes printing by removing paper from the finisher
18	READY (HOLE PUNCH DUST BIN IS FULL)	Punching dust box is full • Scanning is enabled	Resumes printing by removing punching dust from the dust box
19	READY (SADDLE STITCH TRAY FULL)	Saddle stitcher tray is full of paper • Scanning is enabled	
20	READY (CHANGE DRAWER TO CORRECT PAPER SIZE)	Incorrect paper size setting	
21	READY (Performing Auto Calibration)	Displayed during image quality control adjustment • Scanning is enable.	
22	READY (ADD INSERTER PAPER)	No inserter paper • The equipment is ready for scanning and waiting for the operator to select the copying conditions.	Printing is resumed when the [START] button is pressed under the condition the printing UI is displayed ([JOB STATUS] button pressed) after adding inserter paper.

No.	Message	State of equipment	Note
23	READY (FINISHER IN USE)	Finisher manual operating • The equipment is ready for scanning and waiting for the operator to select the copying conditions.	Printing is started when pressing the [START] button.
24	READY (ADD TAB SHEET)	No tab paper • The equipment is ready for scanning and waiting for the operator to select the copying conditions.	Printing is resumed when the [START] button is pressed under the condition the printing UI is displayed ([JOB STATUS] button pressed) after adding tab paper.
25	Ready for bypass feeding	Paper is set on the bypass tray	
26	COPYING	At the copying state	
27	Auto Start	Auto Start is set during printing	Cleared by pressing [FUNCTION CLEAR] button
28	Place Doc. Feeder in the down position	RADF is open when original is placed on RADF	Cleared by closing RADF
29	Place originals in the document feeder	Displayed when the conditions are set and [START] button is pressed with no original placed	Cleared by setting the original
30	Change direction of original	Displayed when the direction of original placed is different from the setting	
31	PRESS [BASIC] and select normal paper size	Displays the warning that the copy is not enabled when any drawer but bypass feed is selected at Cover Sheet Copying Mode or Sheet Insertion Mode	
32	Place last %d originals in doc. feeder entrance tray	Paper jam occurred during copying (RADF scanning)	
33	Add paper	Displayed when the paper in selected drawer is running out	
34	Cannot duplex this size	Displayed when the paper size which is not specified for duplex copying is set	
35	Cannot use this media type	Displayed when the paper size which is not specified for the functions such as stapling or hole punching is set	
36	Set standard size	Displayed when the paper size which is not acceptable is set (depends on the setting)	Re-set the paper size
37	Cannot staple this paper type	Displayed when the paper type which can not be stapled is set at Cover Sheet Copying Mode/Sheet Insertion Mode	Re-set the paper type
38	Cannot duplex this size	Displayed when the paper size which is not specified for duplex copying is set	
39	Cannot use transparency film	Displayed when the paper type which can not be punched is set at Cover Sheet Copying Mode/Sheet Insertion Mode	Re-set the paper type
40	Copy size: A4/LT only	Displayed when the paper size which is not specified for "Book-type duplex copying" or "Dual-page" is set	
41	Copy size: A4/LT and A4-R/LT-R	Displayed when the paper size which is not specified for "Rotate Sort"	
42	CHANGE DRAWER TO CORRECT PAPER SIZE	Displayed when the selected paper size is not in the drawer	
43	Change drawer to correct media type	Displayed when the selected media type is not in the drawer	

No.	Message	State of equipment	Note
44	Select a paper size for bypass feeding	Displayed when paper size needs to be specified for bypass feeding such as duplex copying	
45	Place the blank sheets in bypass tray and select the paper size	Displayed when no paper is in the selected feeder at Cover Copying Mode	
46	Place the blank sheets in the same direction as the originals	Displayed when the direction of cover page is different from that of other pages at Cover Copying Mode	
47	Place the same size blank sheets as the originals	Displayed when the paper size of cover page is different from that of other pages at Cover Copying Mode	
48	Place insertion sheets in the bypass tray and select the paper size	Displayed when no insertion sheet is in the selected drawer at Sheet Insertion Mode	
49	Select the same size insert1 sheets as the originals	Displayed when the size of insertion sheet (sheet 1) is different from that of other pages at Sheet Insertion Mode	
50	Select the same size insert2 sheets as the originals	Displayed when the size of insertion sheet (sheet 2) is different from that of other pages at Sheet Insertion Mode	
51	Set insert1 sheets in the same direction as the originals	Displayed when the direction of insertion sheet (sheet 1) is different from that of other pages at Sheet Insertion Mode	
52	Set insert2 sheets in the same direction as the originals	Displayed when the direction of insertion sheet (sheet 2) is different from that of other pages at Sheet Insertion Mode	
53	Set transparency film in A4/LT direction	Displayed when the selected paper size is other than A4/LT at OHP mode	
54	CANNOT PUNCH THIS SIZE PAPER	Displayed when the selected paper size is not specified for hole punching	
55	Remove paper from the finisher	Displayed when the paper sizes are mixed at Staple Sorting Mode	
56	Cannot staple this size	Displayed when the paper size is not specified for stapling at Staple Sorting Mode	
57	Remove paper from the saddle stitch unit	Finisher is full of papers	
58	Examine stapler	Trouble in the stapler unit in finisher	
59	Check staple cartridge	No stapler in finisher section	
60	Check staple cartridge in the saddle stitch unit	No stapler in saddle stitch unit	
61	Job interrupted job 1 saved	Interrupt copying is accepted	
62	Ready to resume job 1	Interrupt copying is cancelled (finished)	
63	Cannot use AMS mode	Displayed when reproduction ratio is set to be over 200% at AMS Mode on RADF	Set the reproduction ratio 200% or below manually
64	More than 200% is not available	Displayed when reproduction ratio is set manually to be over 200% on RADF	Set the reproduction ratio 200% or below
65	Updated the template setting	Displayed when the template stored is recalled by pressing [TEMPLATE] button	
66	Enter Department Code	Displayed when a button is pressed while the department management setting is available	

No.	Message	State of equipment	Note
67	Cannot copy Check DEPARTMENT COUNTER	Displayed when the number of printouts exceeds the limit number of department counter	
68	Select the same sized Tab sheets as the originals	Displayed when the paper sizes for the tab sheets and originals are different	Select the same size for tab sheets and originals.
69	Select the same sized Inserter sheets as the originals	Displayed when the paper sizes for inserter paper and original are different	Select the same size for the inserter sheets and originals.
70	Set Tab sheets in the same direction as the originals	Displayed when the paper directions for tab paper and original are different	Set the tab sheets in the same direction as the originals.
71	Set Inserter sheets in the same direction as the originals	Displayed when the paper directions for inserter paper and original are different	Set the inserter sheets in the same direction as the originals.
72	Only one paper source can be used with Cover Sheet feature	Displayed when both the cover sheet mode and inserter cover sheet mode are selected	Release either the cover sheet mode or inserter cover sheet mode.
73	Only two paper sources can be used with Sheet Insertion feature	Displayed when all the sheet insertion mode, tab insertion mode and inserter sheet insertion mode are selected	Release any of three modes
74	ADD PAPER TO INSERTER FEEDER	Displayed when the inserter mode is valid and the [START] button is pressed without papers on the tray	<ul style="list-style-type: none"> • Release the inserter mode • Set papers on the inserter tray
75	Set the paper source for Tab sheet	Displayed when the tab paper mode is valid and the tab drawer is not selected	Select the 2nd drawer property to the tab to release this state.
76	Fuser cleaning web decreased	Displayed when the fuser unit cleaning web gets decreased * This message is set not to be displayed at shipment, but the setting can be changed at the setting mode (08-941).	Replace the cleaning web.
77	Time for periodic maintenance (Fuser cleaning web)	Displayed when the fuser unit cleaning web gets run out	Replace the cleaning web.
78	Tab size: A4/LT only	Displayed when the tab paper mode is valid and other than A4/LT is selected for the tab paper size	Select A4 or LT for tab paper.
79	Not enough memory to store original(s) Will you print out stored originals?	Displayed when confirming the user to print out the data as much as stored at memory - full state	
80	Not enough memory to store original(s) Will you send stored originals in?	Displayed when confirming the user to send the FAX data as much as stored at memory - full state	Displayed only in FAX Function
81	Not enough memory to store original(s) Will you save stored originals in?	Displayed when confirming the user to save the scanning data as much as stored at memory-full state	Displayed only in FAX Function
82	The number of originals exceeds the limits Will you copy stored originals?	Displayed when confirming the user to print out the data as much as stored at memory-full state	
83	The number of originals exceeds the limits. Will you send stored originals?	Displayed when confirming the user to send the FAX data as much as stored at memory-full state	Displayed only in FAX Function
84	The number of originals exceeds the limits. Will you save stored originals?	Displayed when confirming the user to save the scanning data as much as stored at memory-full state	Displayed only in Scanning Function

No.	Message	State of equipment	Note
85	Time for periodic maintenance	PM cycle <ul style="list-style-type: none"> Displayed at the time for maintenance Copying is available 	Maintenance and inspection are performed by qualified service technician.
86	READY (CHANGE DRAWER TO CORRECT MEDIA TYPE)	Displays when the printing is stopped because of media type mismatch	
87	PRESS [BASIC] and select normal paper size	Displays the warning that the copy is not enabled when any drawer but bypass feed is selected at Cover Sheet Mode or Sheet Insertion Mode.	
88	Misfeed in copier Press [HELP]	Paper jam in the equipment <ul style="list-style-type: none"> Displayed when paper jam occurred in the equipment 	Remove the paper in the equipment according to the messages displayed on the panel.
89	Call for service	Displayed when motor, sensor, switch, etc. do not work properly	Turn OFF the main power switch and solve the problem, then turn ON the power.
90	Please try again after a while	Displayed when the Department Code can no be keyed in immediately after power-ON.	Leave it for a while and key in the code again
91	Set standard size	Displayed when the paper size which is not acceptable is set (depends on the setting)	Reset the paper size
92	Press START button to copy after changing setting	Displayed when the build job is set	
93	The number of builds exceeds the limits will you copy stored originals?	Displayed when the number of builds exceeds the limits	Select either printing or canceling
94	The number of builds exceeds the limits will you save stored originals?	Displayed when the number of builds exceeds the limits	Select either printing or saving
95	This setting cannot be changed now	Displayed when the setting is changed during the build job is discontinued	
96	Service recommended for SPC	Displayed when the surface potential control error occurs	Refer to chapter 5.1.16. /Service Handbook.
97	Service recommended for IQC	Displayed when the image quality control error occurs	Refer to chapter 5.1.15. /Service Handbook.
98	(Messages XX(SPC) and XX(IQC) above appear alternately.)	Displayed when the surface potential control error and the image quality control error occur	Refer to chapter 5.1.15 and 5.1.16. /Service Handbook.
99	Cannot copy this size original	Displayed if copying is not enabled when any drawer (except bypass feeding) is selected in the following cases <ul style="list-style-type: none"> [BLANK TAB INSERT] or [COPIED TAB INSERT] is set as is the tab paper mode for the selected drawer. [COPY ON TAB] is set but the tab paper mode is not for the selected drawer. 	
100	READY(K-TONER NOT RECOGNIZED)	Displayed when a toner cartridge is not correctly installed or an unrecommended one is	
101	Toner low	The amount remaining in the toner cartridge has become low.	If you want to replace the toner cartridge at this time, do so following the procedure of the Troubleshooting Guide.

5.3 Relation between the Equipment State and Operator's Operation

Operation	During READY status	During warming-up	Auto job start reserved	Scanning original/ Scanning original and printing out the copy
Press [ENERGY SAVER] button	Switches to energy saving mode	Display not changed	Display not changed	Display not changed
Press [ACCESS] button	When the setting of the department management or user management information is valid, displays ACCESS screen.	When the setting of the department management or user management information is valid, displays ACCESS screen.	Display not changed	Display not changed
Press [INTERRUPT] button	Switches to interrupt mode	Display not changed	Display not changed	Display not changed (LED blinking)
Press [FUNCTION CLEAR] button after setting the copy mode	Copy mode is cleared after the copy mode is set	Copy mode is cleared after the copy mode is set	Auto job start cancelled	Display not changed
Press [STOP] button	Display not changed	Display not changed	Auto job start cancelled	Scanning or printing out stops, and "READY Press START to copy" and "MEMORY CLEAR" are displayed
Press [CLEAR] button after setting the copy mode	Number of printouts changes to 1 while the setting remains unchanged after the copy mode is set	Number of printouts changes to 1 while the setting remains unchanged after the copy mode is set	Display not changed	Display not changed
Press [CLEAR] button after keying in numbers (digital keys)	Number keyed in changes to 1 after being entered	Number keyed in changes to 1 after being entered	Display not changed	Display not changed
Press [FAX] button	Displays FAX screen	Display not changed	Display not changed	Display not changed
Press [COPY] button	Display not changed	Display not changed	Display not changed	Display not changed
Press [SCAN] button	Displays SCAN screen	Display not changed	Display not changed	Display not changed
Press [e-FILING]	Displays E-FILING screen	Display not changed	Display not changed	Display not changed
Press [USER FUNCTIONS] button	Displays USER FUNCTIONS screen	Display not changed	Display not changed	Display not changed
Press [START] button with the original set on RADF	Displays "COPYING"	"Wait Warming Up Auto Start" is displayed	Display not changed	Display not changed
Press [MENU] button	Displays MENU screen	Display not changed	Display not changed	Display not changed
Press [COUNTER] button	Displays COUNTER screen	Display not changed	Display not changed	Display not changed

Operation	Printing out the copy	During paper jam	When interrupting	When displaying HELP screen	During energy saving mode
Press [ENERGY SAVER] button	Display not changed	Display not changed	Display not changed	Switches to energy saving mode	Energy saving mode is cleared and displays BASIC screen
Press [ACCESS] button	When the setting of the department management or user management information is valid, displays ACCESS screen.	Display not changed	When the setting of the department management or user management information is valid, displays ACCESS screen.	When the setting of the department management or user management information is valid, displays ACCESS screen.	Display not changed
Press [INTERRUPT] button	Display not changed (LED blinking)	Display not changed	Returns to the status before interrupting	Switches to interrupting mode	Display not changed
Press [FUNCTION CLEAR] button after setting the copy mode	Copy mode is cleared after the copy mode is set	Display not changed	Copy mode is cleared after the copy mode is set	Displays BASIC screen after the copy mode is set and then cancelled	Display not changed
Press [STOP] button	Printing out stops, and "READY Press START to copy" and "MEMORY CLEAR" are displayed	Display not changed	Display not changed	Display not changed	Display not changed
Press [CLEAR] button after setting the copy mode	Number of printouts changes to 1 while the setting remains unchanged after the copy mode is set	Display not changed	Number of printouts changes to 1 while the setting remains unchanged after the copy mode is set	Number of printouts changes to 1 while the setting remains unchanged after the copy mode is set	Display not changed
Press [CLEAR] button after keying in numbers (digital keys)	Number keyed in changes to 1 after being entered	Display not changed	Number keyed in changes to 1 after being entered	Number keyed in changes to 1 after being entered	Display not changed
Press [FAX] button	Displays FAX screen	Display not changed	Display not changed	Displays FAX screen	Displays FAX screen
Press [COPY] button	Display not changed	Display not changed	Display not changed	Display not changed	Displays COPY screen
Press [SCAN] button	Displays SCAN screen	Display not changed	Display not changed	Displays SCAN screen	Displays SCAN screen
Press [e-FILING] button	Displays e-FILING screen	Display not changed	Display not changed	Displays e-FILING screen	Displays e-FILING screen
Press [USER FUNCTIONS] button	Displays USER FUNCTIONS screen	Display not changed	Display not changed	Displays USER FUNCTIONS screen	Display not changed
Press [START] button with the original set on RADF	Displays "COPYING" and RADF starts feeding	Display not changed	Displays "COPYING" and RADF starts feeding	Displays "COPYING" and RADF starts feeding	Energy saving mode is cleared and displays BASIC screen
Press [MENU] button	Display not changed	Display not changed	Display not changed	Displays MENU screen	Displays MENU screen
Press [COUNTER] button	Display not changed	Display not changed	Display not changed	Displays COUNTER screen	Displays COUNTER screen

5.4 Description of Operation

5.4.1 Dot matrix LCD circuit

1. Structure

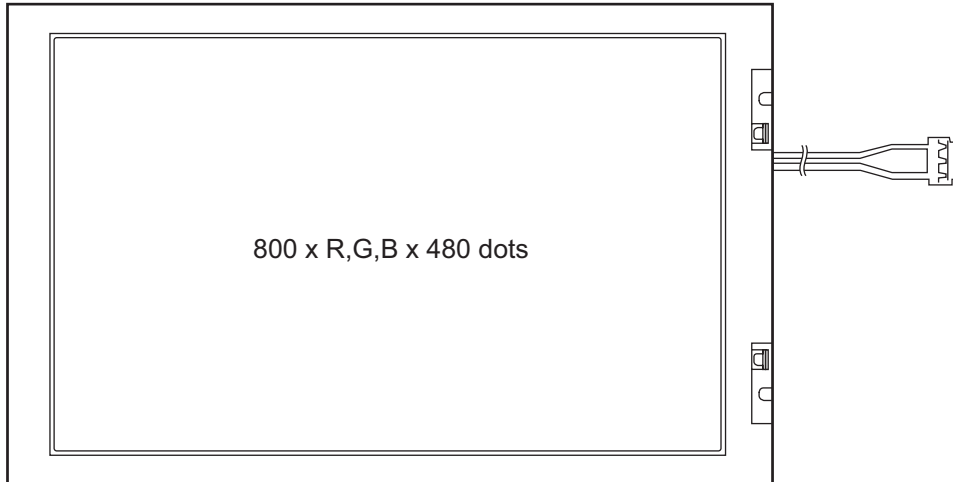

Fig. 5-4

The DSP-LCD-470 is an TFT type LCD with (800 x R, G, B) x 480-dot display capacity. It consists of a driver LSI, frame, printed circuit board, and straight type CCFL backlight.

- * TFT: Thin Film Transistor
- * CCFL: Cold Cathode Fluorescent Lamp

2. Block diagram

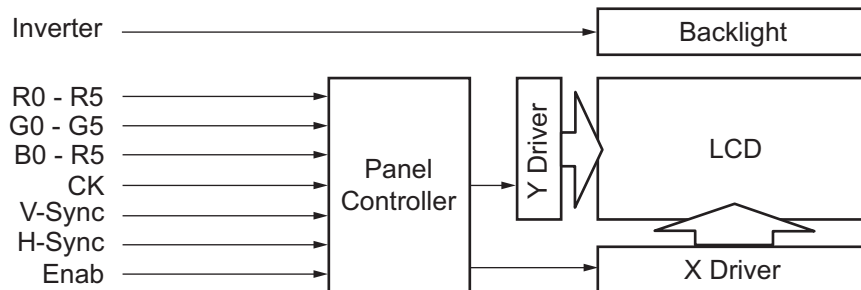

Fig. 5-5

5.4.2 LED display circuit

Method of LED display

Example: Displaying "COPY"

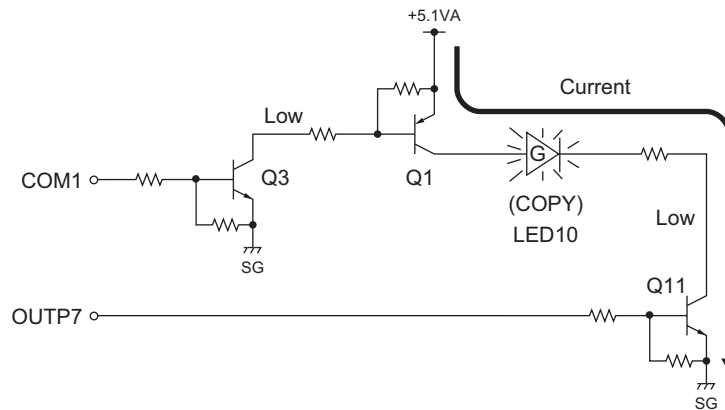

Fig. 5-6

The transistors (Q3 and Q1) are turned ON when the COM1 signal becomes Low level.

Also, when OUTP7 signal changes to Low level, the current flows from +5.1VA via the transistor (Q1) to the LED10 (COPY) to turned ON the LED10.





Conditions to turn ON the LED

1. The transistor (Q1) connected to the LED anode is ON.
2. The transistor (Q11) connected to the LED cathode side is ON.

The LED is turned ON when 1) and 2) are satisfied.

5.5 Disassembly and Replacement

[A] Control panel unit

- (1) Take off the front cover, front right inner cover, toner cartridge driving unit, and toner recycling unit.
( P.2-41 "[A] Front cover (Upper/Lower)",
 P.2-41 "[B] Front right inner cover",
 P.11-12 "[A] Toner cartridge drive unit",
 P.11-15 "[B] Toner recycle unit").
- (2) Remove 2 screws and take off the toner cartridge catcher.

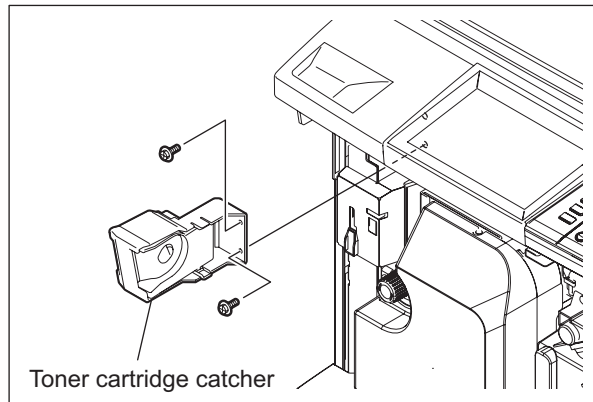

Fig. 5-7

- (3) Remove 2 screws and take off the control panel lower cover.

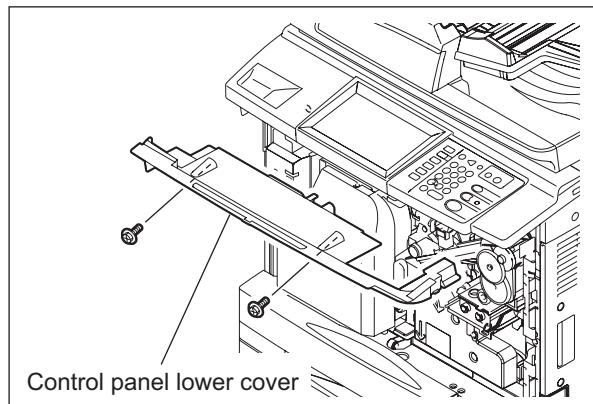

Fig. 5-8

- (4) Disconnect 1 connectors.

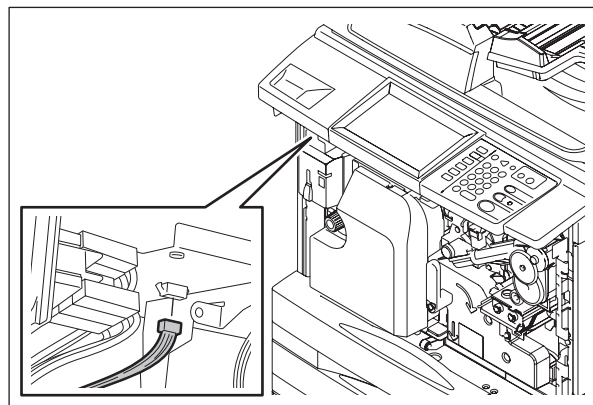

Fig. 5-9

- (5) Take off the top right cover and right upper cover.
 (📖 P.2-42 "[C] Top right cover",
 (📖 P.2-43 "[F] Right upper cover",
- (6) Release the harness from the clamp.
- (7) Remove 1 screw and take off the clamp.

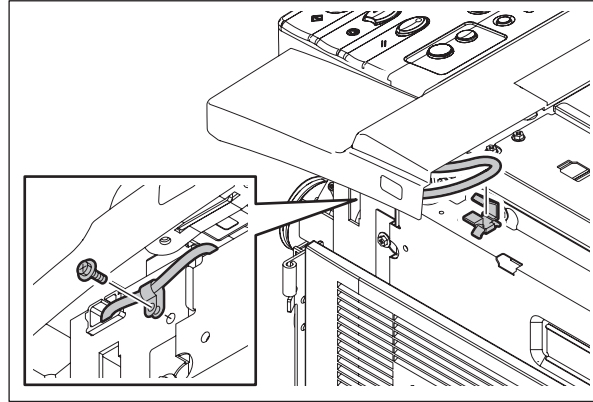

Fig. 5-10

- (8) Remove 3 screws.
- (9) Release the harness from the clamp and then place the control panel unit with its reverse side up.

Note:

When assembling the unit, be sure that the harness is not caught.

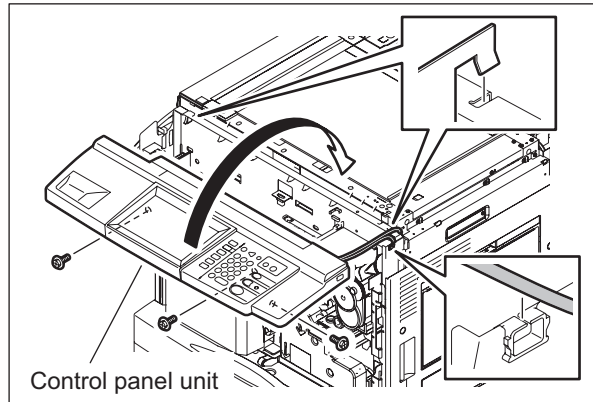

Fig. 5-11

- (10) Take off 3 clamps and disconnect 1 connector.
- (11) Remove 2 screws, take off a USB port and then the control panel unit.

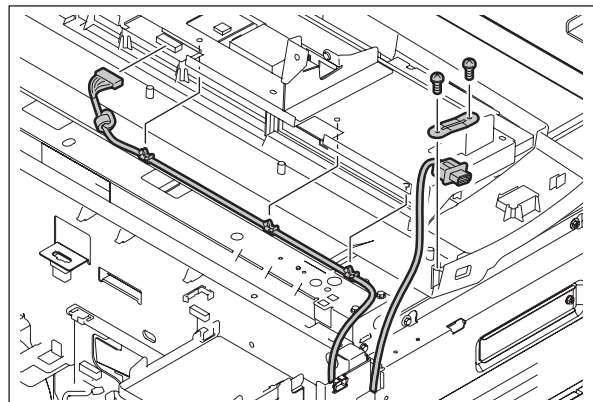

Fig. 5-12

[B] LCD inverter board (INV-LCD)

- (1) Take off the control panel unit.
☞ P.5-12 "[A] Control panel unit"
- (2) Remove 2 screws and disconnect 2 connectors, and then take off the LCD inverter board.

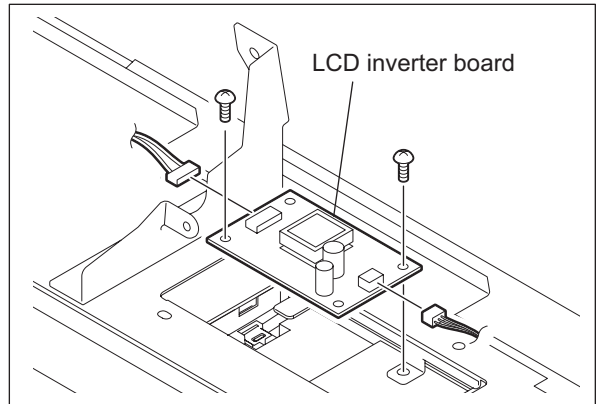

Fig. 5-13

[C] DSP board (DSP)

- (1) Take off the control panel unit.
☞ P.5-12 "[A] Control panel unit"
- (2) Remove 2 connectors of the LCD inverter board.

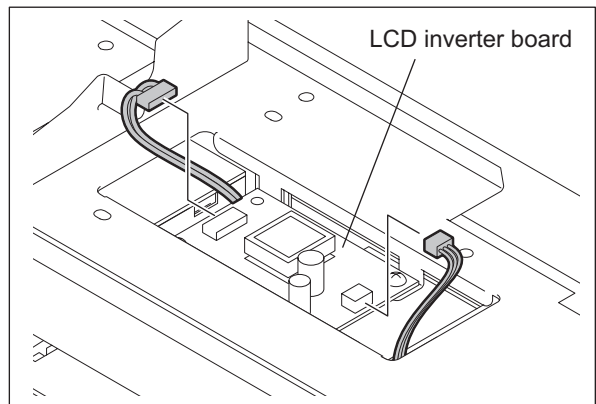

Fig. 5-14

- (3) Remove 2 screws and disconnect 2 shielding wire, and then take off the bracket.

Note:

When assembling, be sure to install them in the correct order.

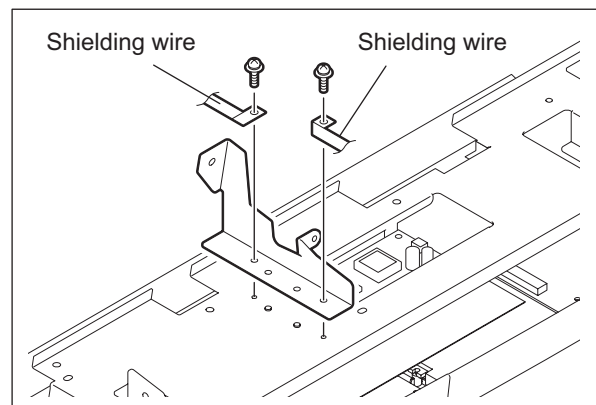

Fig. 5-15

- (4) Remove 9 screws and then disconnect 1 shielding wire and 1 connector. Then take off the base stay.

Note:

When assembling, do not forget to connect the connector and shielding wire.

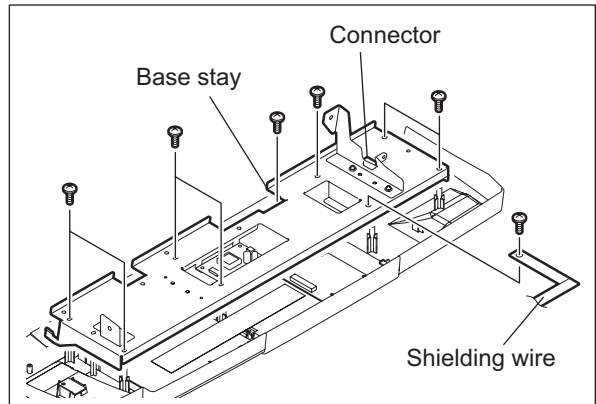

Fig. 5-16

- (5) Disconnect 3 connectors.
- (6) Remove 3 screws and take off the DSP board and the sheet.

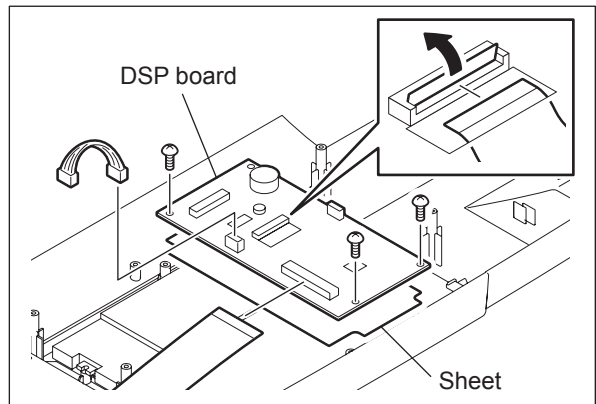



Fig. 5-17

[D] KEY board (KEY)

- (1) Take off the control panel unit.
 P.5-12 "[A] Control panel unit"
- (2) Disconnect 2 connectors of the LCD inverter board.

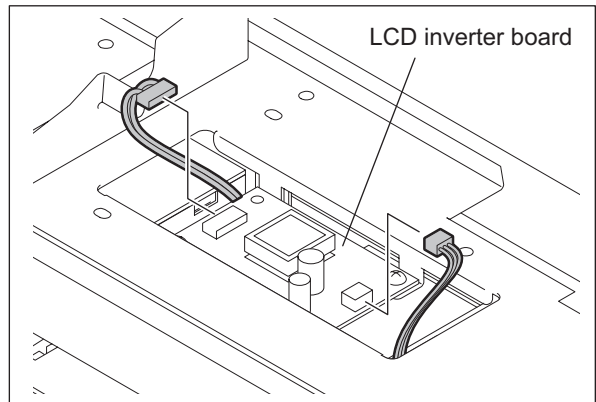

Fig. 5-18

- (3) Remove 2 screws and disconnect 2 shielding wire, and then take off the bracket.

Note:

When assembling, be sure to install them in the correct order.

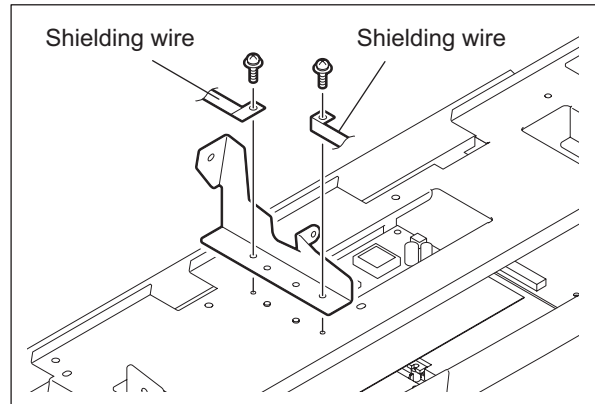

Fig. 5-19

- (4) Remove 9 screws and then disconnect 1 shielding wire and 1 connector. Then take off the base stay.

Note:

When assembling, do not forget to connect the connector and shielding wire.

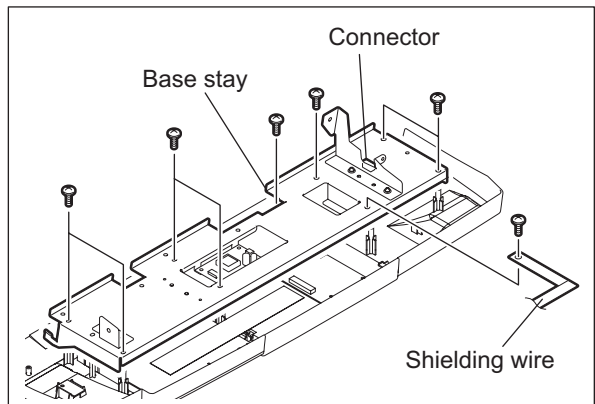

Fig. 5-20

- (5) Disconnect 1 connector and remove 12 screws. Take off the KEY board.

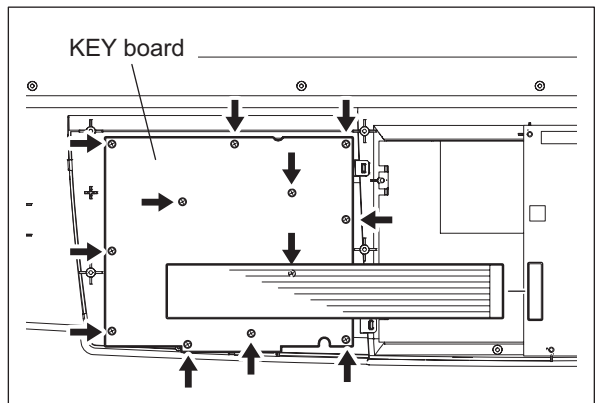

Fig. 5-21

[E] LCD panel (LCD) / Touch panel (TCP)

- (1) Take off the control panel unit.
📖 P.5-12 "[A] Control panel unit"
- (2) Remove the DSP board.
📖 P.5-14 "[C] DSP board (DSP)"
- (3) Remove 1 screw and take off the harness clamp.
- (4) Remove 2 screws and take off the LCD.

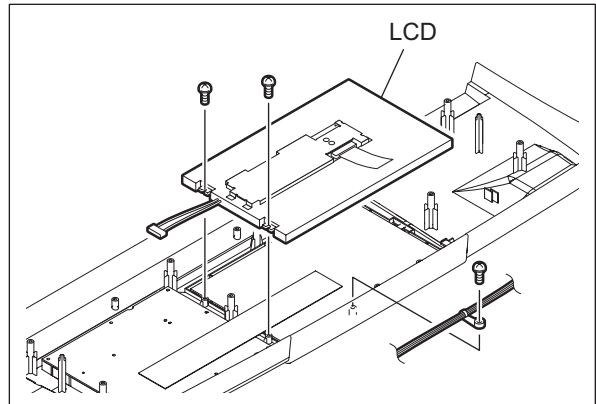

Fig. 5-22

- (5) Take off the touch panel.

Notes:

1. When installing the touch panel, be sure that the panel faces the right direction.
2. Be sure that no dust or stain is on the LCD panel or the touch panel before the installation.

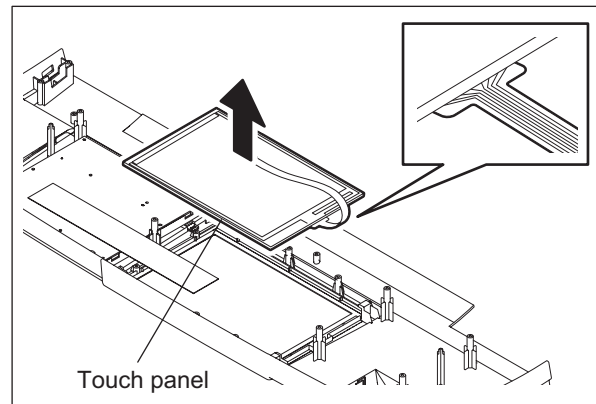

Fig. 5-23

[F] Control panel cover

- (1) Release the 4 latches, and take off the control panel cover.

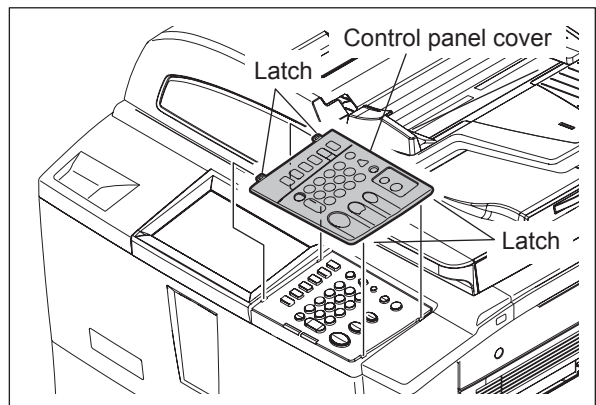

Fig. 5-24

6. SCANNING SECTION

6.1 Function

In the scanning section of this equipment, the surface of an original is irradiated with a direct light and the reflected light is led through mirrors and lens to the CCD where the optical-to-electrical conversion is performed, converting the optical image data into an electrical (analog) signal. This analog signal is changed to a digital signal, which then performs various corrective processes necessary for image formation. After that, an arithmetic operation is performed on the digital signal, which is then transmitted to the data writing section.

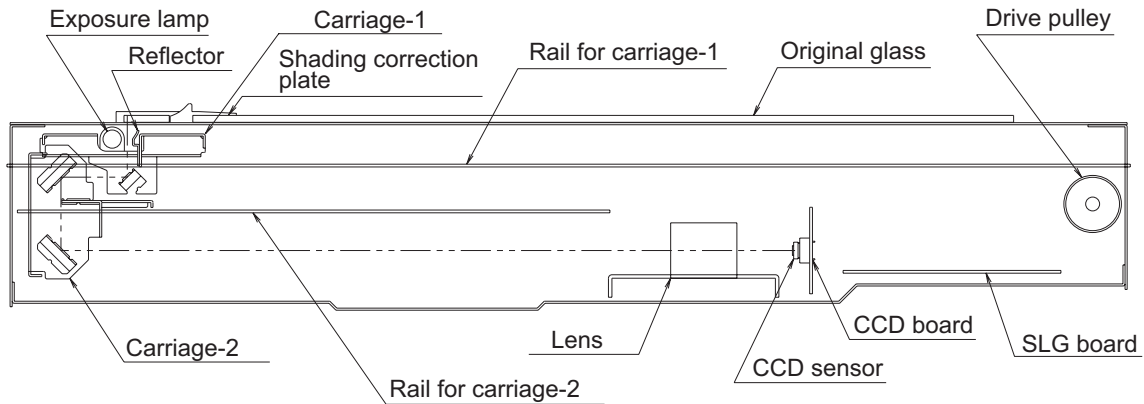

Fig. 6-1

6.2 Construction

The construction and purpose of the scanning system are described in this section.

1. Original glass

This is a glass for placing original. The light from the exposure lamp (EXP) is irradiated to the original through this glass.

The ADF original glass is used when original is read with the Automatic Document Feeder. Original is transported on the ADF original glass by the Automatic Document Feeder, and the transported original is read under the ADF original glass by the carriage.

Do not use such solvents as alcohol when cleaning the surface of the ADF original glass, because it is coated so as not to be scratched by originals.

2. Carriage-1

The carriage-1 consists of the exposure lamp (EXP), lamp inverter board (INV-EXP), reflector, mirror-1, etc. It is driven by the scan motor (M1) and scans the original on the glass.

- Exposure lamp (EXP)

This lamp is the light source to irradiate the original on the glass (one 29W Xenon lamp).

- Lamp inverter board (INV-EXP)

This inverter controls lighting of the Xenon lamp.

- Reflector

This is a reflecting plate to efficiently lead the light from the exposure lamp (EXP) to the surface of the original on the glass.

- Mirror-1

This mirror leads the light reflected from the original to the mirror-2 described later.

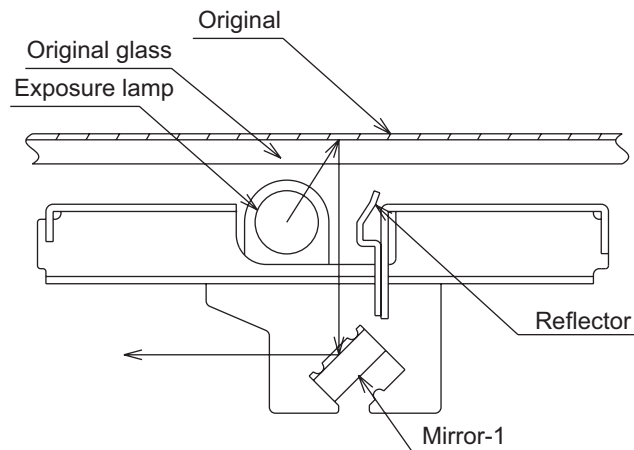

Fig. 6-2

3. Carriage-2

The carriage-2 consists of mirror-2, mirror-3, etc. and leads the reflected light from the mirror-1 through mirrors-2 and -3 to the lens.

This carriage-2 is also driven by the scan motor (M1) as in the same manner of the carriage-1, at half the scanning speed of carriage-1 (the scanning distance is also half of carriage-1).

4. Lens unit

The light reflected from the mirror-3 is led to the CCD placed at the focal point of the lens which is fixed at this position.

5. Automatic original detection sensor (S1-5)

The size of the original placed on the glass is instantly detected using the automatic original detection sensors (S1-5) fixed on the base frame without moving the carriage-1.

6. CCD board (CCD)

This is a board to convert the light led through the lens unit into the minute analog signal (optical-to-electrical conversion), and transfer it to the SLG board (SLG).

7. SLG board (SLG)

This is a board to perform the image correction, such as the signal synthesis, signal amplification, A/D conversion and shading correction.

6.3 Operation

6.3.1 Scanner motor (M1)

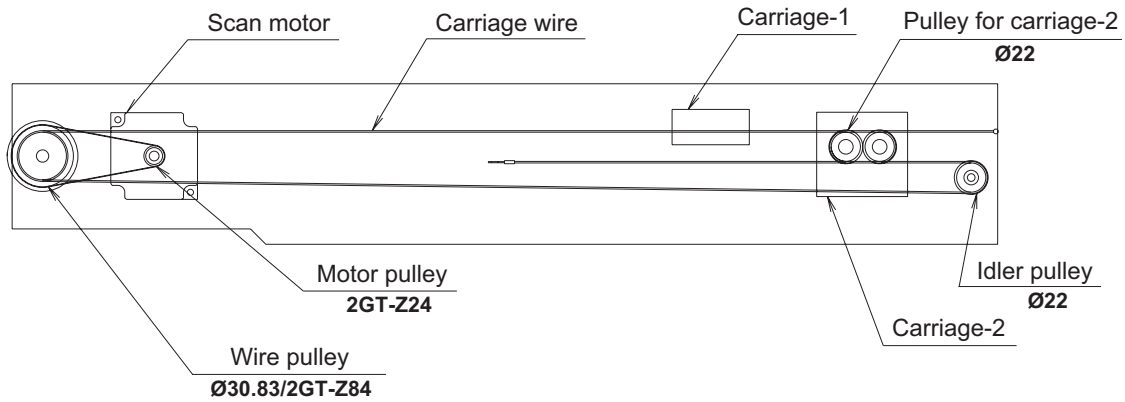

Fig. 6-3

- Scanning an original on the original glass
This motor drives the carriages-1 and -2 through the timing belt and carriage wire. First, the scan motor (M1) drives carriages-1 and -2 to their respective home positions. The home position is detected when carriage-1 passes the carriage home position sensor (S6). When the [START] key is pressed, both carriages start to move and scan the original on the glass.
- Scanning an original on the RADF
Carriage-1 stays at the shading position during the shading correction, and at the scanning position during the scanning operation.

6.3.2 Two-phase motor drive circuit (fixed-current type)

The scan motor (M1) with the unipolar fixed current chopper method is driven by the stepping motor driver STK672-410 (IC19).

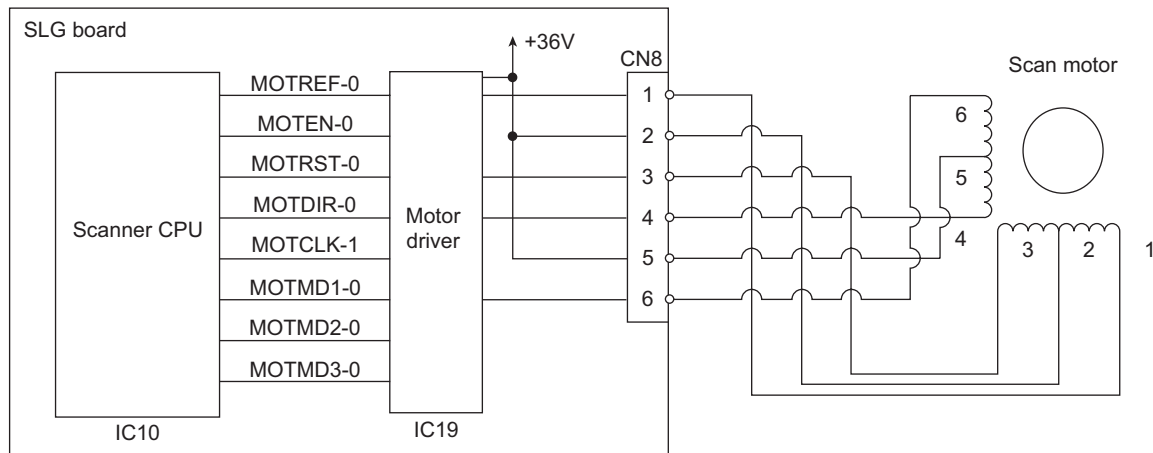

Fig. 6-4

Input signals

Clock input	MOTCLK-1	Input	Motor is rotated by setting number of pulses. * Internal circuit of the motor driver works when the first pulse becomes ON and the last pulse becomes OFF.
Set the direction of motor rotation	MOTDIR-0	Input	The direction of the motor rotation is determined by setting the level of signal. "L".....Clockwise direction (as seen from the output shaft) "H"....Counterclockwise direction (as seen from the output shaft) Note: When the MOTMD3-0 is "L", do not change the rotation direction within 6.25μsec. before the first pulse of the MOTCLK-1 becomes ON and after the last pulse becomes OFF.
Cut off the drive output	MOTEN-0	Input	Excitation drive is forcibly turned ON/OFF. "H"....Normal operation (Excited) "L"....Excitation drive is forcibly shut off (Not excited)
Voltage to set value for the motor current	MOTREF-0	Input	Motor wire current value is set in the range of 0 to 3 (A)/phase by applying the analog voltage 0 to 5 (V).
Set the excitation mode (1) to (3)	MOTMD1-0 MOTMD2-0 MOTMD3-0	Input	Set the excitation mode. Note: Do not change the setting within 5μsec. after the first pulse of the MOTCLK-1 becomes ON and the last pulse becomes OFF.
Reset	MOTRST-0	Input	Reset for the whole system. Internal circuit of the driver is initialized by setting the motor to "L" level (pulse interval: 10μsec. or more).

6.4 Control for Exposure Lamp

6.4.1 General description

Control circuit of the exposure lamp consists of the following 3 blocks.

1. Lighting device for the Xenon lamp (Lamp inverter board)
Turns the exposure lamp ON/OFF.
2. CCD sensor circuit
This circuit works to convert the reflected light amount from the original surface and the shading correction plate to the electrical signals. The reflected light amount from the shading correction plate is read to control the exposure amount.
3. Image processing circuit
The output signals from the CCD are digitized and the image processing such as gamma correction and shading correction is applied to them.

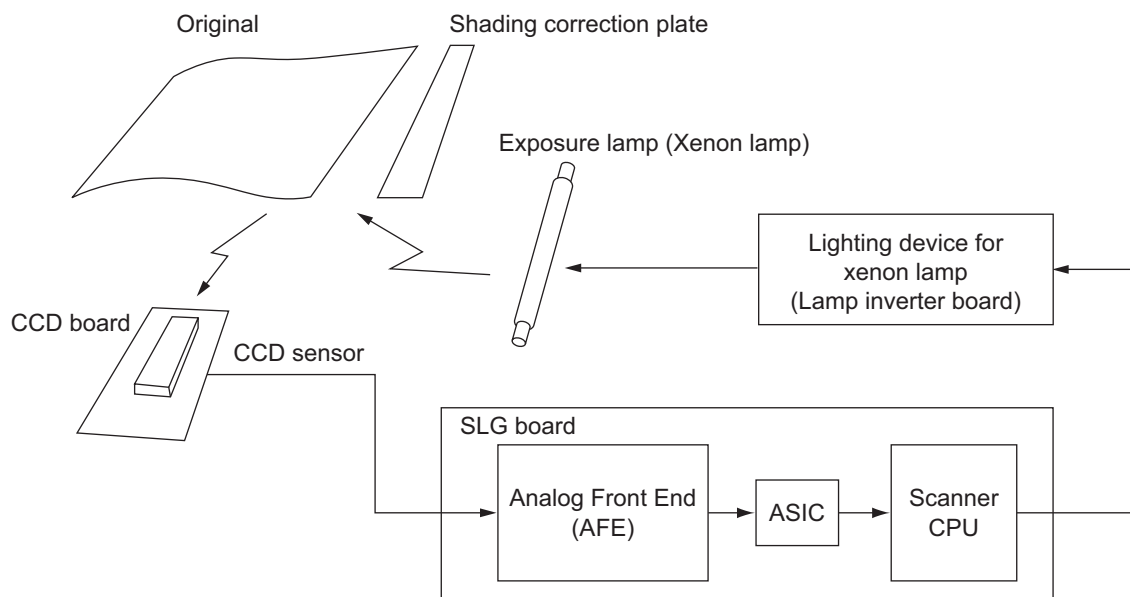

Fig. 6-5

6.4.2 Exposure lamp

External electrode type Xenon fluorescent lamp is used as an exposure lamp in this equipment.

1. Structure

The fluorescer is applied to the inside surface of the lamp pipe (except for a part which serves as an opening) which is filled with the Xenon gas.

A pair of the external electrodes covered by film with adhesive agent is attached around the pipe.

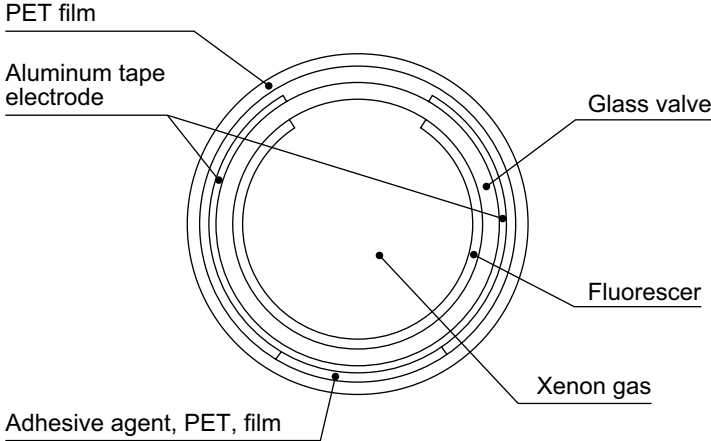
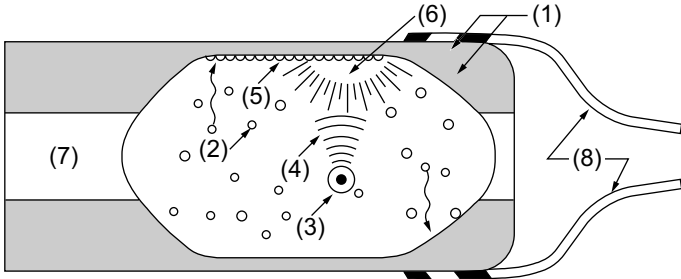

Fig. 6-6

2. Behavior inside the lamp

The electron inside the pipe is led to the electric field by applying voltage to the pair of the external electrodes, and the discharge is started.

The electrons then flow and clash with the Xenon atoms inside the pipe to excite them and allow them to generate ultraviolet rays. This ultraviolet rays convert the fluorescer into visible light.



- (1) Electrode
- (2) Electron
- (3) Xenon atom
- (4) Ultraviolet ray
- (5) Fluorescer
- (6) Visible light (irradiated from the opening to outside the pipe)
- (7) Opening
- (8) Harness

Fig. 6-7

6.4.3 Control circuit for exposure lamp

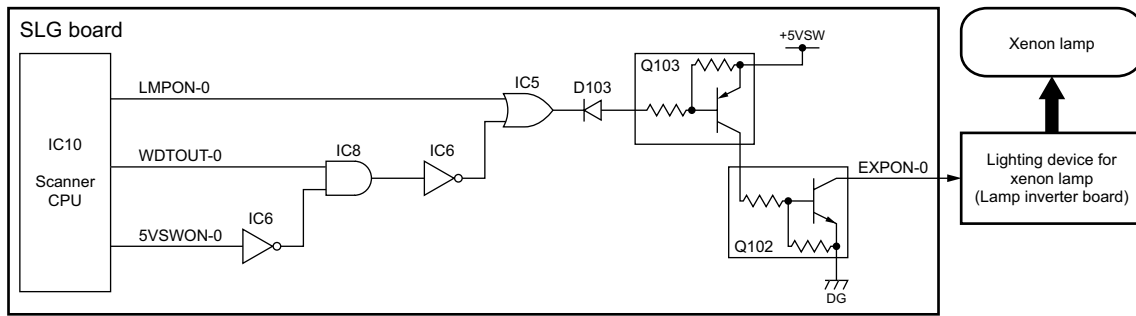

Fig. 6-8

LMPON-0 (Lamp drive signal)	WDTOUT-0	5VSWON-0	+5VSW	Q102	Xenon lamp	State of equipment
L	H	L	ON	ON	ON	Normal operation
H	H	L	ON	OFF	OFF	
X	L	X	OFF	OFF	OFF	Scanner CPU overdriving
X	H	H	OFF	OFF	OFF	Call for Service

6.5 CCD Control

6.5.1 Opto-electronic conversion

A CCD (charge-coupled device) is used to produce an electrical signal corresponding to the reflected light amount from the original. The CCD is a one-chip opto-electronic conversion device, comprised of several thousand light-receiving elements arranged in a line; each one of them is a few microns square. This model is equipped with a CCD which has 7,500 light-receiving elements.

Each element of the light-receiving section consists of the semiconductive layers P and N. When the light irradiates the element, the light energy produces a (-) charge in the layer P; the amount of the charge produced is proportional to the energy and irradiating time. The charges produced in the light-receiving section are then sent to the transfer section where they are shifted by the transfer clock from left to right as shown in the figure below, and are finally output from the CCD. At this time, to increase the transfer speed of the CCD, image signals are separated and output in parallel via two channels.

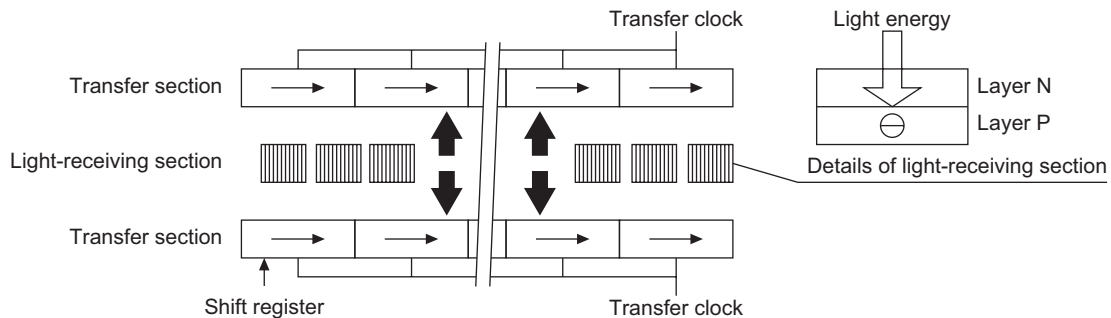

Fig. 6-9

6.5.2 Shading correction

Signal voltages read by the CCD have the following characteristics.

1. Light source has variation in its light distribution.
2. Since the light beam reflected from the original is converged using a lens, the light path is the shortest at the center of the CCD and the longest at ends. This causes difference in the amount of light reaching the CCD (i.e. the light amount is maximum at the CCD center, gradually decreases toward ends).
3. Each of the 7,500 elements varies in the opto-electronic conversion efficiency. These variations need to be corrected and this correction is referred to as shading correction. Based on the black and white data obtained in advance, a normalization process using the following formula is applied to the raw image data to correct lighting variance and element variation of the image data.

$$I = k \times \frac{(S-K)}{(W-K)}$$

- k: Coefficient
S: Image data before correction
K: Black data (stored in "Black" memory)
W: White data (stored in "White" memory)

6.6 Automatic Original Size Detection Circuit

This circuit detects the size of original (standard sizes only) using the reflection type photosensors arranged on the base frame of the scanner unit.

6.6.1 Principle of original size detection

The reflection type photosensors are placed on the base frame of the scanner unit as shown in the figure below. Each sensor consists of an infrared light emitting diode (LED) on the light emitting side, and a phototransistor on the light receiving side.

When there is an original on the original glass, light beams from the LEDs are reflected by the original and led to the phototransistors. This means that the size of the original is detected by checking which phototransistors are turned on or are not.

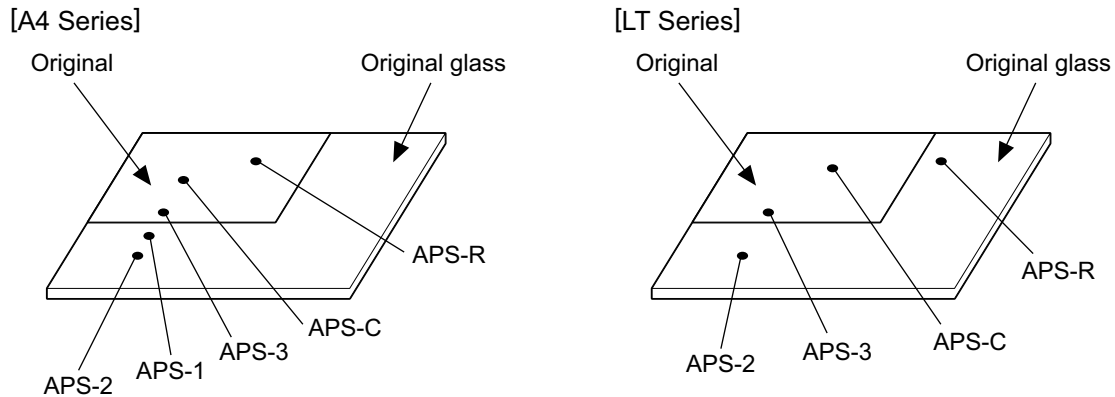

Fig. 6-10

6.6.2 Process of original size detection

1. When the equipment is in the original size detection mode, the carriage-1 is set at its home position.
2. When the RADF is opened, the sensors receive the light reflected from the original and if one of the matrix conditions shown in 4) for original sizes is satisfied, the size of the original is instantly detected.
3. The output signal from each sensor is input to the CPU on the scanner control PC board to determine the size of the original.

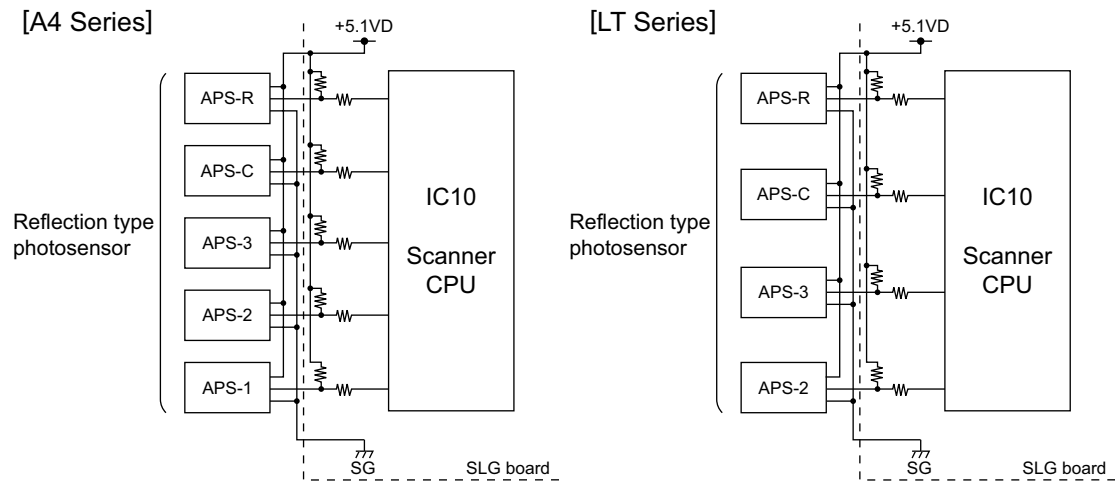

Fig. 6-11

Sensor detection points

[A4 Series]

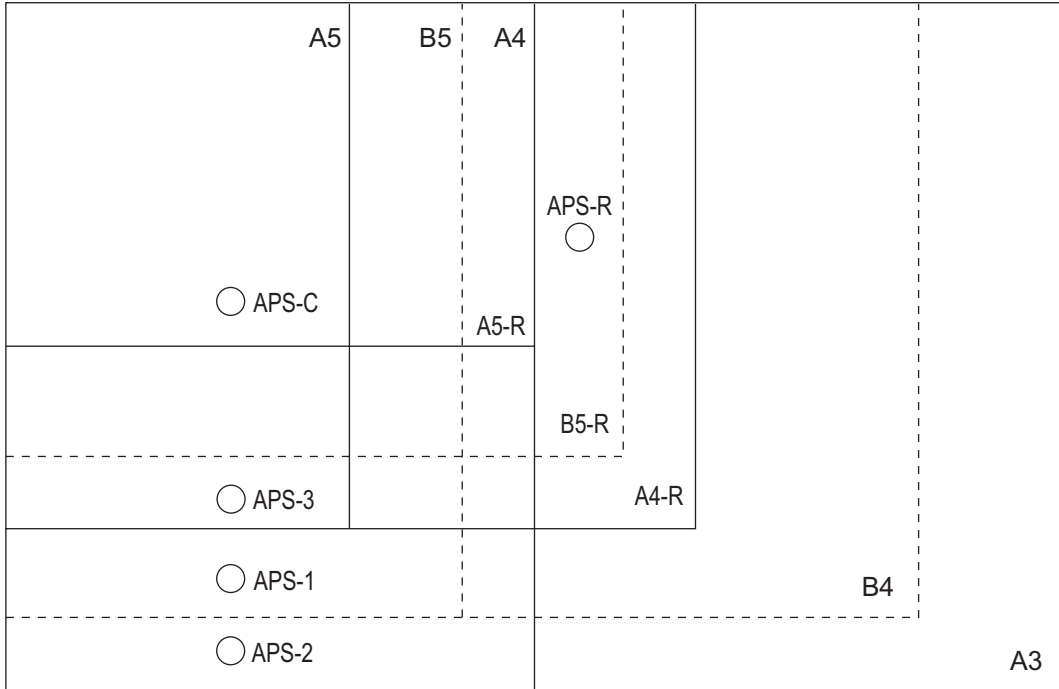

Fig. 6-12

[LT Series]

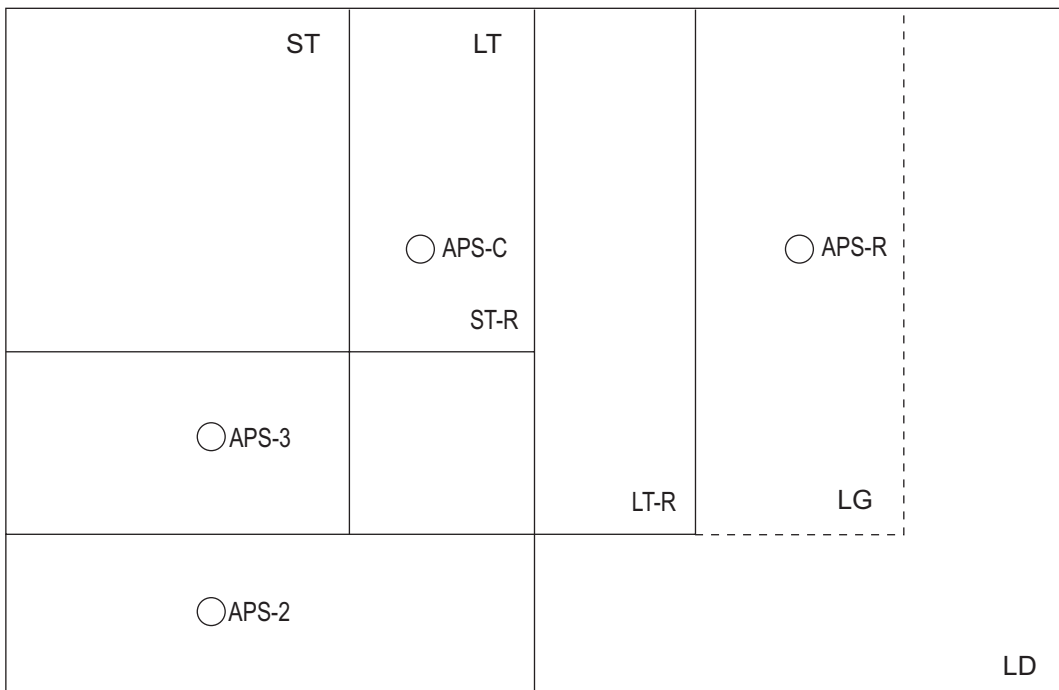

Fig. 6-13

4. Original size is determined by the combination of the signals output from each detection point. Combination charts for size determination of A4 series and LT series are as followed.

Size judgement	APS-1	APS-2	APS-3	APS-C	APS-R
A3	0	0	0	0	0
A4	0	0	0	0	1
B4	0	1	0	0	0
B5	0	1	0	0	1
A4-R	1	1	0	0	0
A5	1	1	0	0	1
B5-R	1	1	1	0	0
A5-R	1	1	1	0	1

Size judgement	APS-2	APS-3	APS-C	APS-R
LD	0	0	0	0
LT	0	0	0	1
LG	1	0	0	0
LT-R	1	0	0	1
ST	1	0	1	1
ST-R	1	1	0	1

Code	Output signal	Original
1	H	Not available
0	L	Available

- * When the platen sensor is OFF;
- The following points are determined by the output signals from APS sensors
 - Size (The combination of the signals satisfy the above chart)
: Size is displayed on the control panel and an appropriate paper and reproduction ratio are selected.
 - Size retention (The combination of the signals do not satisfy the above chart)
: Retains the latest original size recognized (or no original state) until a new paper size is recognized.
 - No original (output from all the sensors are "1".)
: Reproduction ratio and paper size are not selected.
 - Size change is always observed and detected.
 - Carriage-1 stays at the standby position even if the reproduction ratio changes corresponding to the change of the original size.
- * When the platen sensor is ON;
Retains the latest original size (or no original state) recognized right before the platen sensor is turned ON regardless of the state of the APS sensor output signals.

About reflection type photosensor

The reflection type photosensor is comprised of an infrared light emitting diode and a phototransistor. It uses the pulse modulation to detect an original.

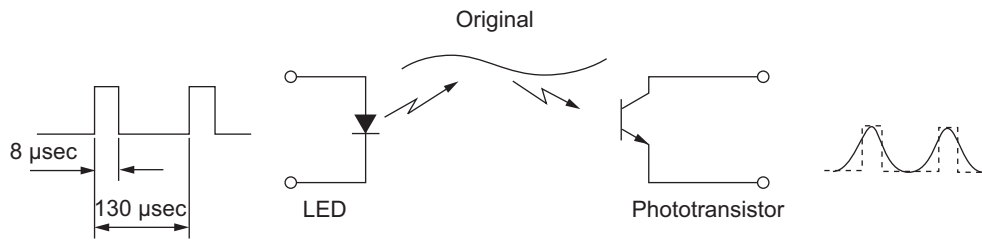



Fig. 6-14

The light emitting diode is driven by a pulse having a 130-μsec cycle and an 8-μsec ON time. When the phototransistor receives the same signal as this pulse, it is determined that there is an original. The pulse modulation is performed inside the reflection type phototransistor.

6.7 Disassembly and Replacement

[A] Original glass

- (1) Take off the top right cover
( P.2-42 "[C] Top right cover").
- (2) Remove 3 screws to take off the original glass holder.

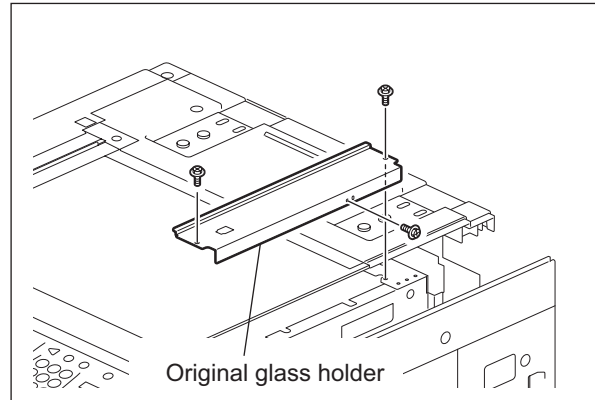

Fig. 6-15

- (3) Remove 2 caps and 2 screws to take off the original glass.

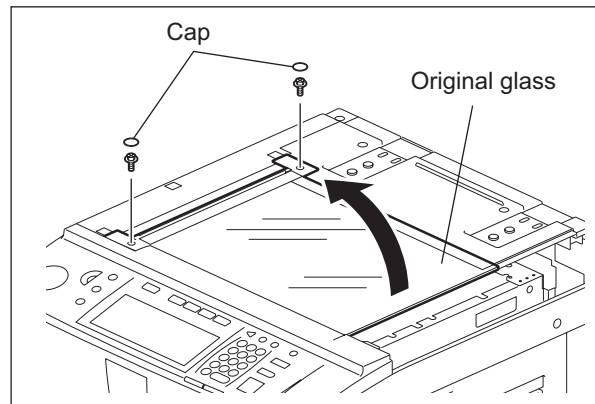

Fig. 6-16

[B] Lens cover

- (1) Take off the original glass
(☞ P.6-13 "[A] Original glass").
- (2) Disconnect 2 connectors.
- (3) Remove 10 screws to take off the lens cover.

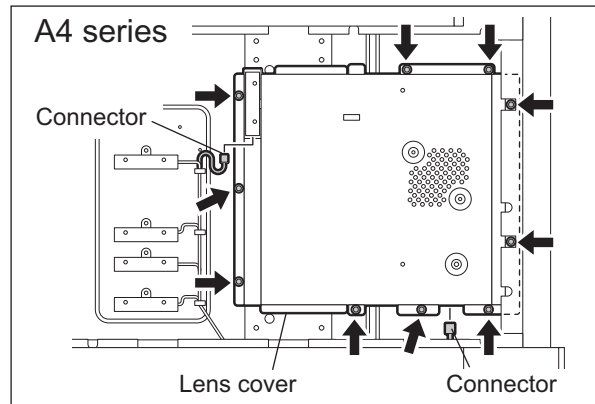

Fig. 6-17

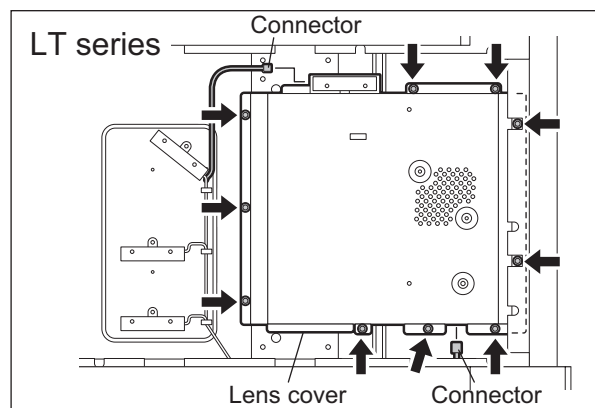

Fig. 6-18

[C] Automatic original detection sensor (APS sensor) (S1 / S2 / S3 / S4 / S5)

- (1) Take off the lens cover
(☞ P.6-14 "[B] Lens cover").
- (2) Remove 2 screws to take off the remaining APS sensor with its bracket.

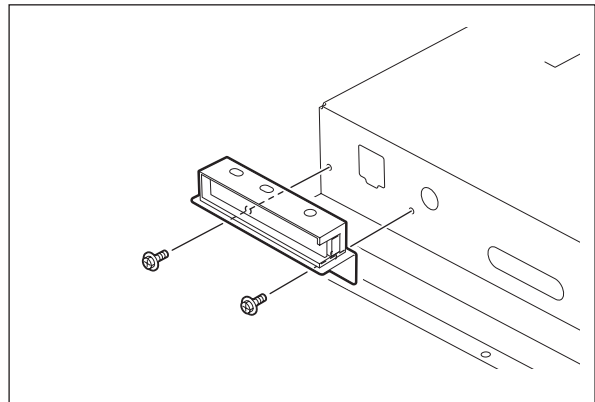

Fig. 6-19

- (3) Remove 1 screw to take off this APS sensor (S5) from its bracket.

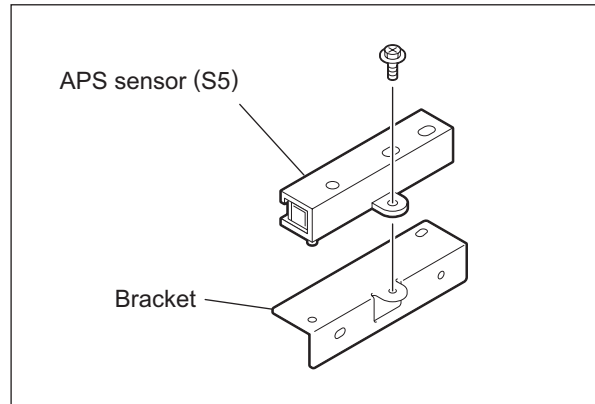

Fig. 6-20

[C-1] A4 series (S1 / S2 / S3 / S4)

- (1) Take off the lens cover (P.6-14 "[B] Lens cover").
- (2) Take off 4 APS sensors by disconnecting 1 connector and removing 1 screw for each sensor.

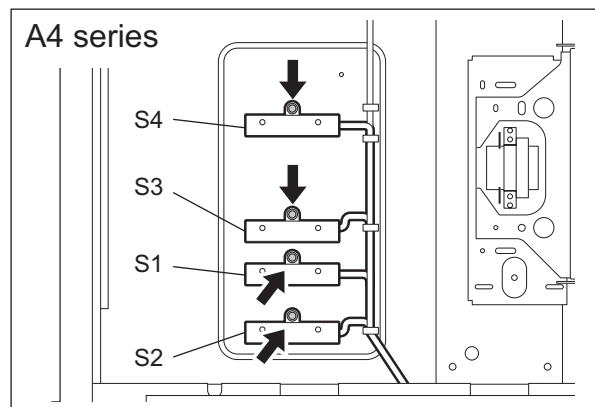

Fig. 6-21

[C-2] LT series (S2 / S3 / S4)

- (1) Take off the lens cover (P.6-14 "[B] Lens cover").
- (2) Take off 3 APS sensors by disconnecting 1 connector and removing 1 screw for each sensor.

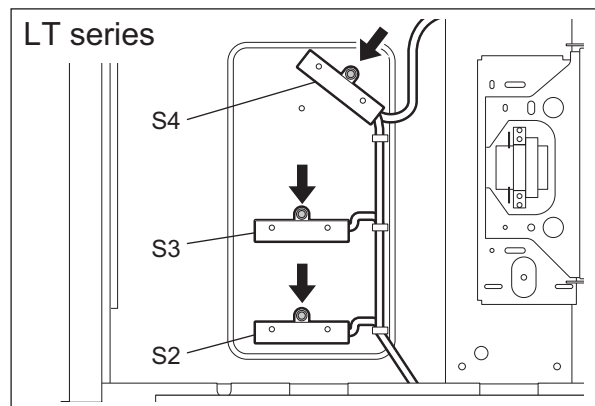



Fig. 6-22

[D] SLG board cooling fan (M23)

- (1) Take off the lens cover
( P.6-14 "[B] Lens cover").
- (2) Disconnect 1 connector and remove 2 screws to take off the SLG board cooling fan.

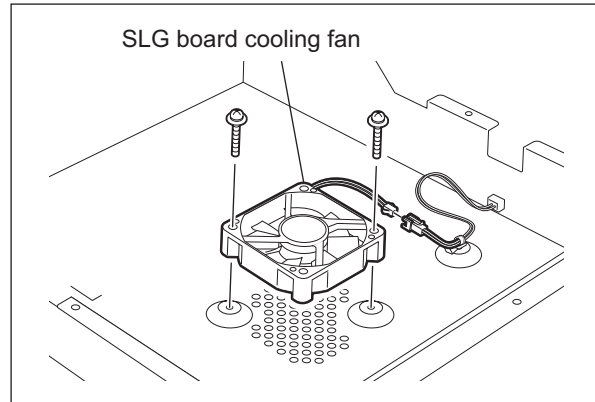



Fig. 6-23

[E] Exposure lamp (EXP)

- (1) Take off the top rear cover
( P.2-42 "[E] Top rear cover").
- (2) Take off the original glass
( P.6-13 "[A] Original glass").
- (3) Move the carriage-1 to the left side.

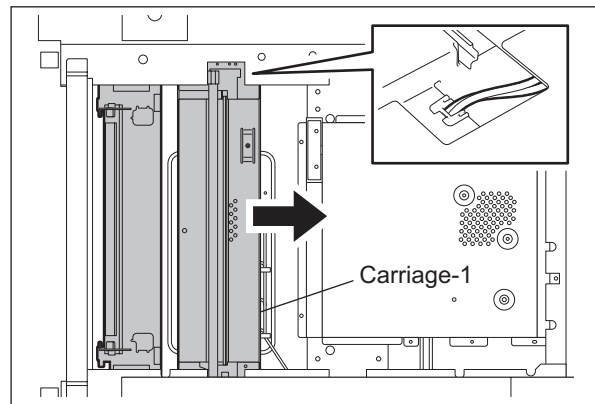

Fig. 6-24

- (4) Disconnect the connector, release the clamp and remove 1 screw of the exposure lamp.

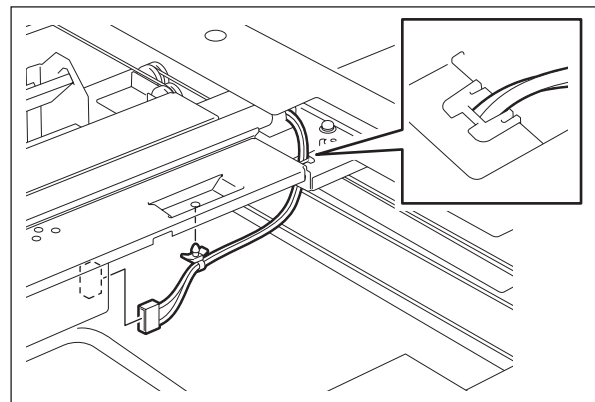

Fig. 6-25

- (5) Move the carriage-1 to the position where the side of the frame is cut out.
- (6) Lift up the exposure lamp by holding its rear side to take it off.

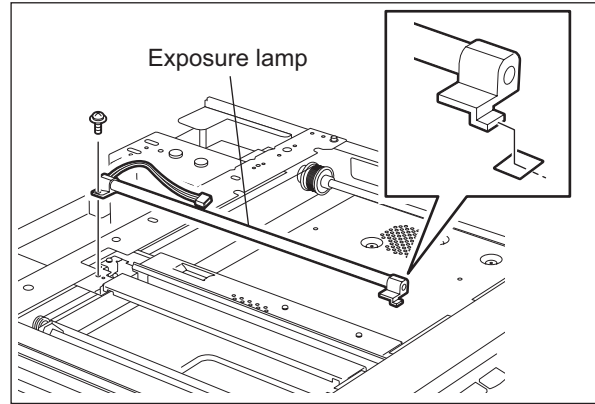

Fig. 6-26

Note:

Rotate the drive pulley to move the carriage.

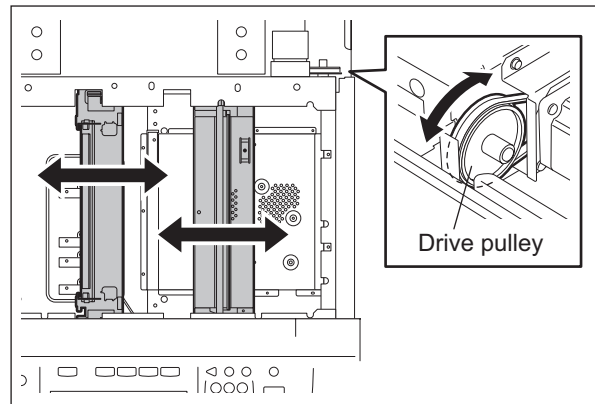

Fig. 6-27

[F] Scanning section control PC board (SLG)

- (1) Take off the lens cover
(P.6-14 "[B] Lens cover").
- (2) Disconnect 8 connectors and remove 4 screws to take off the SLG board.

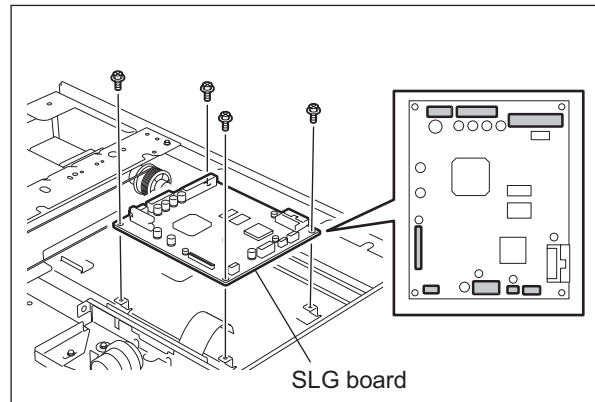

Fig. 6-28

[G] Lens unit

- (1) Take off the lens cover (P.6-14 "[B] Lens cover").
Disconnect 1 connector, remove 4 screws and remove 2 washers to take out the lens unit.

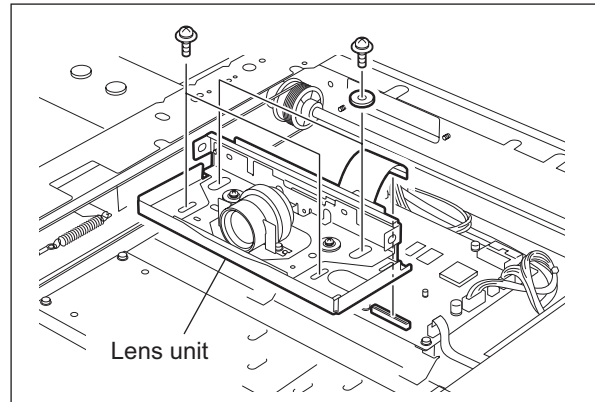

Fig. 6-29

Notes:

1. When replacing the lens unit, do not touch 10 screws denoted with arrows in the figure.

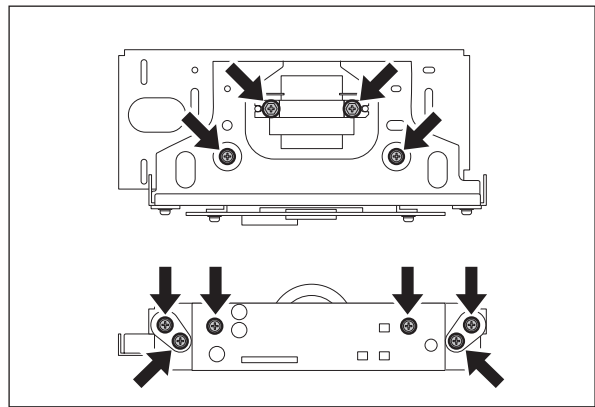

Fig. 6-30

2. Handle the unit with extra care. Do not touch the adjusted area or lens.

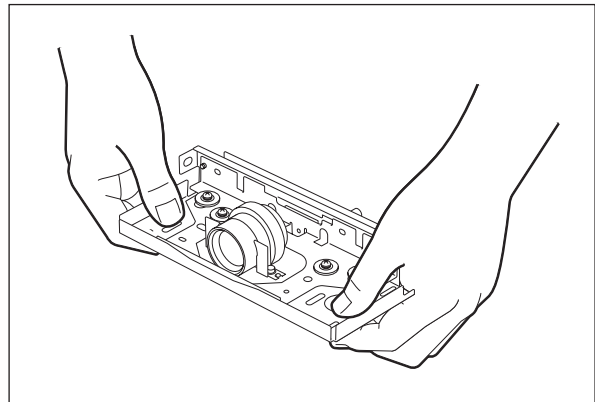



Fig. 6-31

[H] Carriage-1

- (1) Take off the lens cover
( P.6-14 "[B] Lens cover").
- (2) Move the carriage-1 to the left side and remove 2 screws.

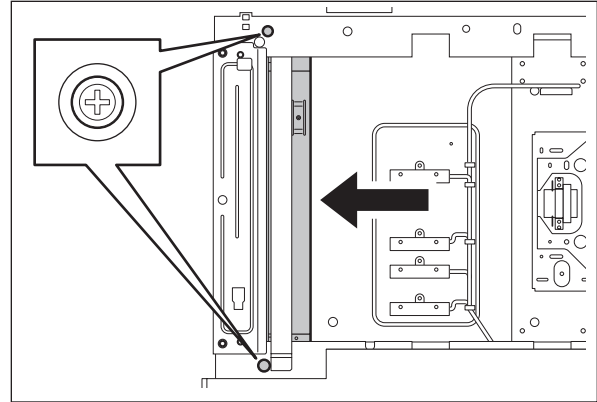

Fig. 6-32

- (3) Move the carriage-1 to the position where the side of the frame is cut out, and then pull its bracket downward.

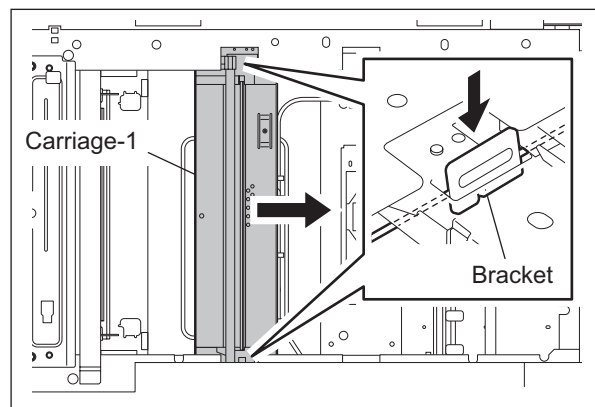

Fig. 6-33

- (4) Disconnect 1 connector of the SLG board. Then remove 4 seals and release the lamp harness from 1 clamp.

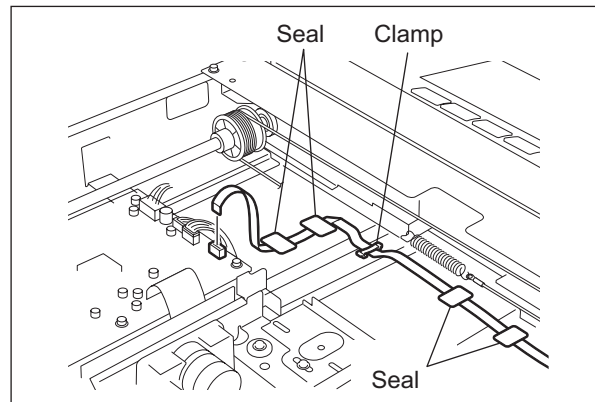

Fig. 6-34

Notes:

Be sure to install the lamp harness by following the procedure below.

1. Using alcohol, clean the area where the seal is to be attached.
2. Align the black line on the lamp harness with the position as shown in the figure, and fix it with a seal.

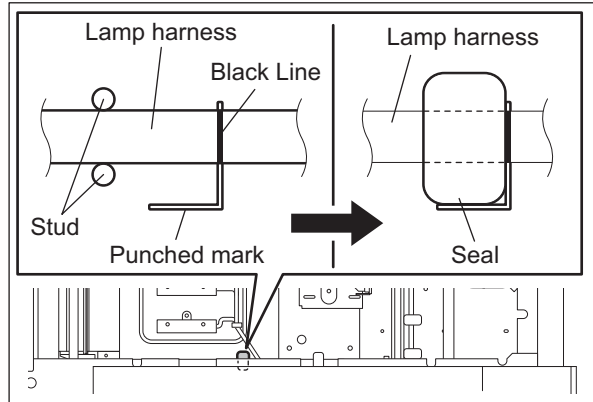

Fig. 6-35

3. Align the bent portion of the lamp harness with the position as shown in the figure, and fix it with a clamp.
4. Attach 3 seals to each position of the punched mark and fix the lamp harness.
5. After the installation, move carriage-1 towards the left and confirm that there is no abnormality in the lamp harness, such as twisting.

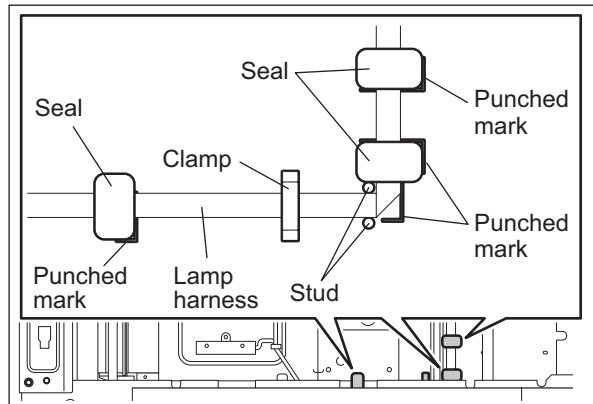

Fig. 6-36

- (5) Rotate the carriage-1 in the direction shown in the figure at right, paying attention not to touch the mirror. Then take out the carriage-1.

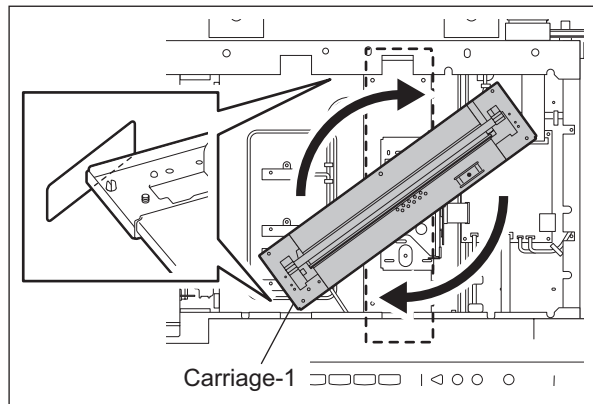

Fig. 6-37

Note:

When installing the carriage-1, fix its bracket temporarily at the cutout of the frame. After that, move the carriage until it touches the left side of the frame, and then tighten 2 screws to fix it permanently.

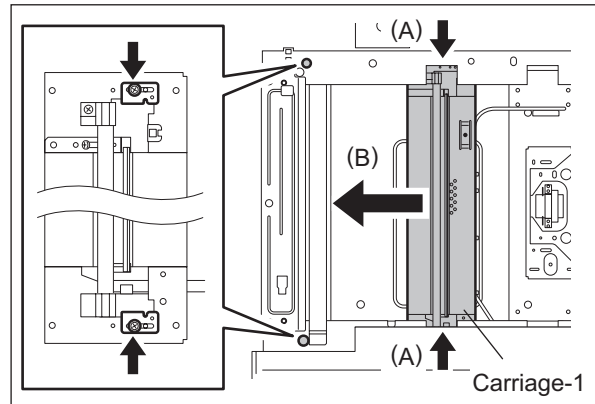

Fig. 6-38

[I] Carriage-2

- (1) Take off the carriage-1
(P.6-19 "[H] Carriage-1").
- (2) Install the wire holder jig on the wire pulley to prevent the wire from being loosened.

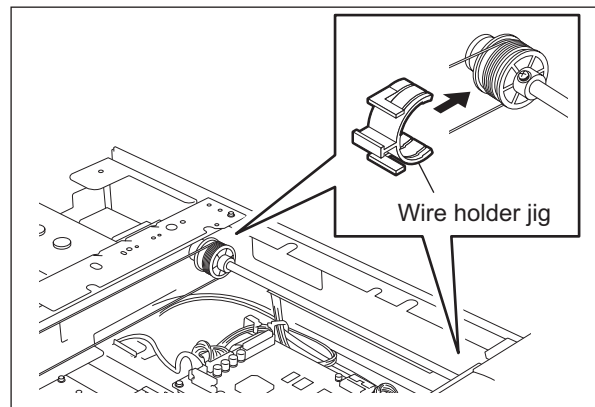

Fig. 6-39

- (3) Remove the tension spring.

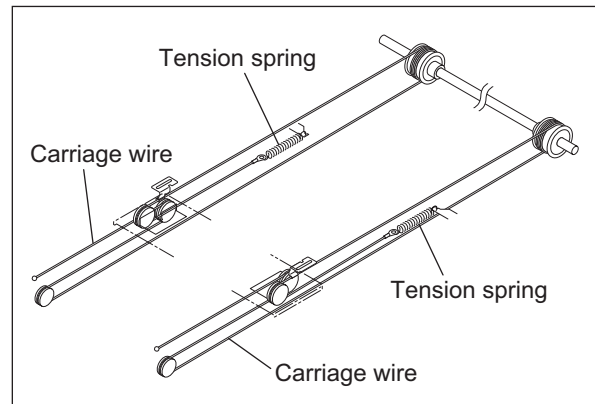

Fig. 6-40

- (4) Remove the wire and slant the carriage-2 to take it out upward.

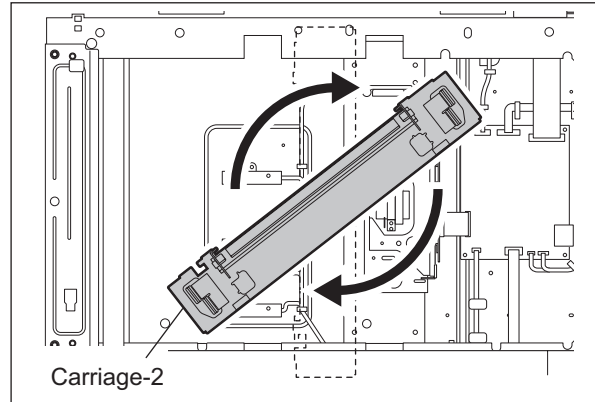



Fig. 6-41

[J] Lamp inverter board (INV-EXP)

- (1) Take off the carriage-1
( P.6-19 "[H] Carriage-1").
- (2) Disconnect 2 connectors and remove 2 screws to take off the lamp inverter board.

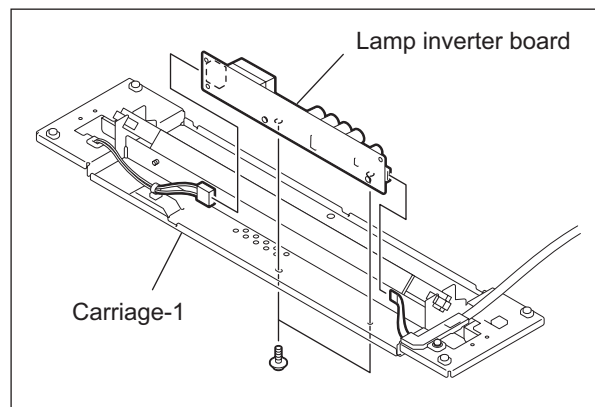



Fig. 6-42

[K] Scan motor [M1]

- (1) Take off the top rear cover and the rear cover
( P.2-42 "[E] Top rear cover",
 P.2-45 "[L] Rear cover").
- (2) Disconnect the connector of the scan motor.
Then remove 2 screws to take off the scan motor.

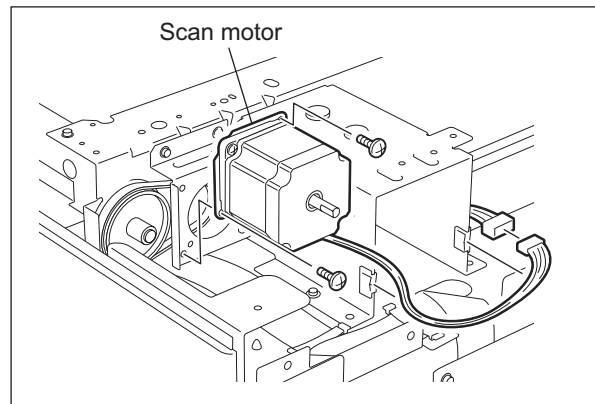

Fig. 6-43

Note:

Adjust the belt tension with a belt tension jig when installing the motor.

<Adjustment procedure for the belt tension>

1. Remove 5 screws to take off the DF bracket.

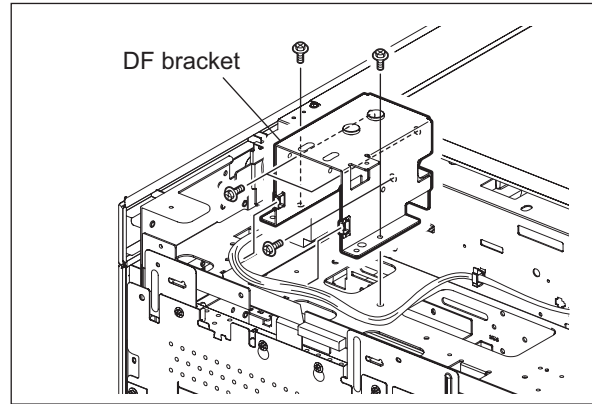

Fig. 6-44

2. Hook the belt tension jig to the position as shown in the figure.
3. Loosen the 2 screws, which fix the motor bracket, and then tighten them when the belt is strained.
4. Remove the belt tension jig and install the DF bracket.

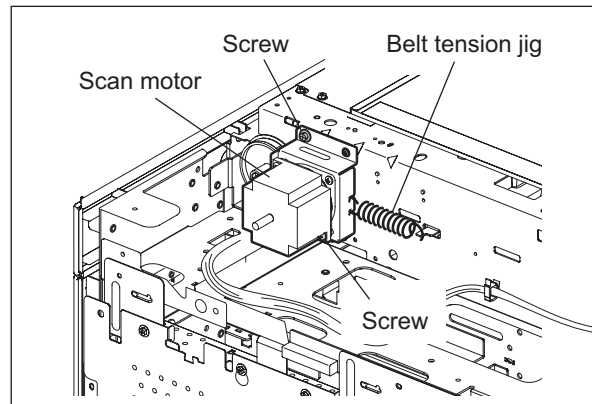

Fig. 6-45

[L] Carriage home position sensor (S6)

- (1) Take off the top left cover (P.2-42 "[D] Top left cover").
- (2) Remove the protection sheet.
- (3) Disconnect 1 connector to take off the carriage home position sensor.

Note:

When the sensor has been replaced, be sure to put a new protection sheet.

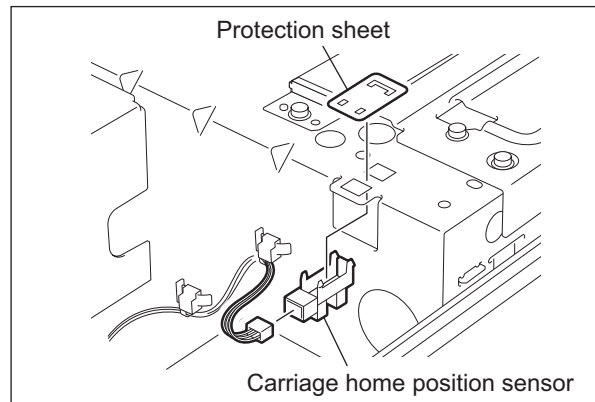

Fig. 6-46

[M] Platen sensor (S53)

- (1) Take off the top rear cover.
(☞ P.2-42 "[E] Top rear cover").
- (2) Take off the rear cover.
(☞ P.2-45 "[L] Rear cover").
- (3) Remove 1 clip to take off the actuator.

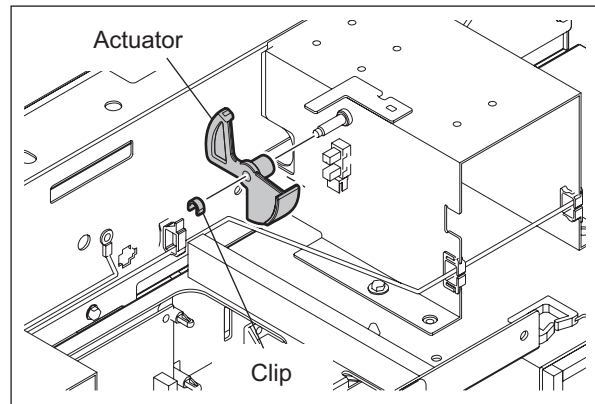

Fig. 6-47

- (4) Disconnect 1 connector and release 2 latches. Then take off the platen sensor.

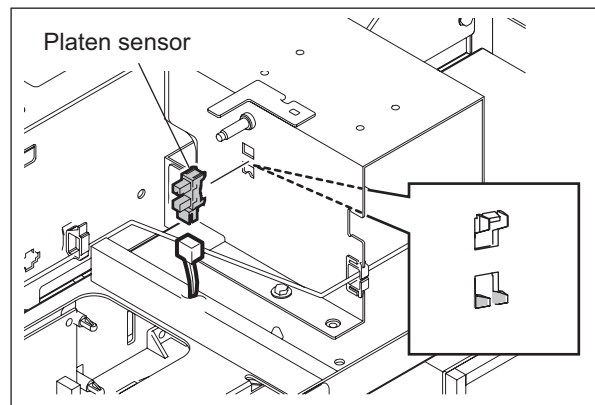

Fig. 6-48

7. LASER OPTICAL UNIT

7.1 General Description

When scanned images and print data are printed, the laser optical unit creates a latent image by converting the digital image signals into laser beams and radiating them onto the photoconductive drum.

The image signals are converted into a light emission signal of the laser diode on the laser driving board (LDR1, LDR2), and are radiated on the drum through optical elements such as the cylinder lenses, polygonal mirror and f θ lens. This unit must not be disassembled in the field because it is finely adjusted and very sensitive to dust.

The laser unit with 2 beams is used only for the e-STUDIO755/855, and the 1-beam type for the e-STUDIO555/655.

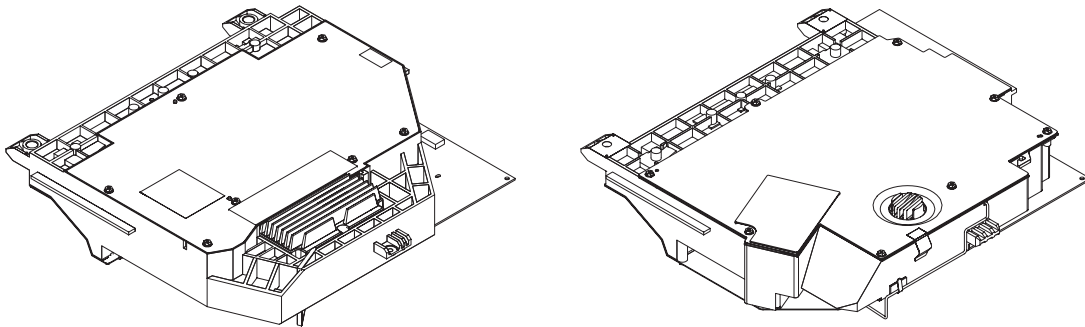
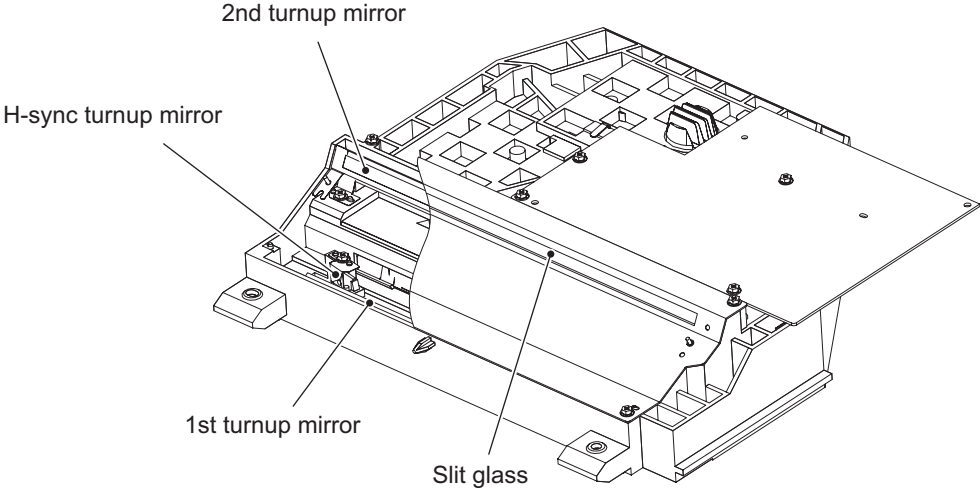
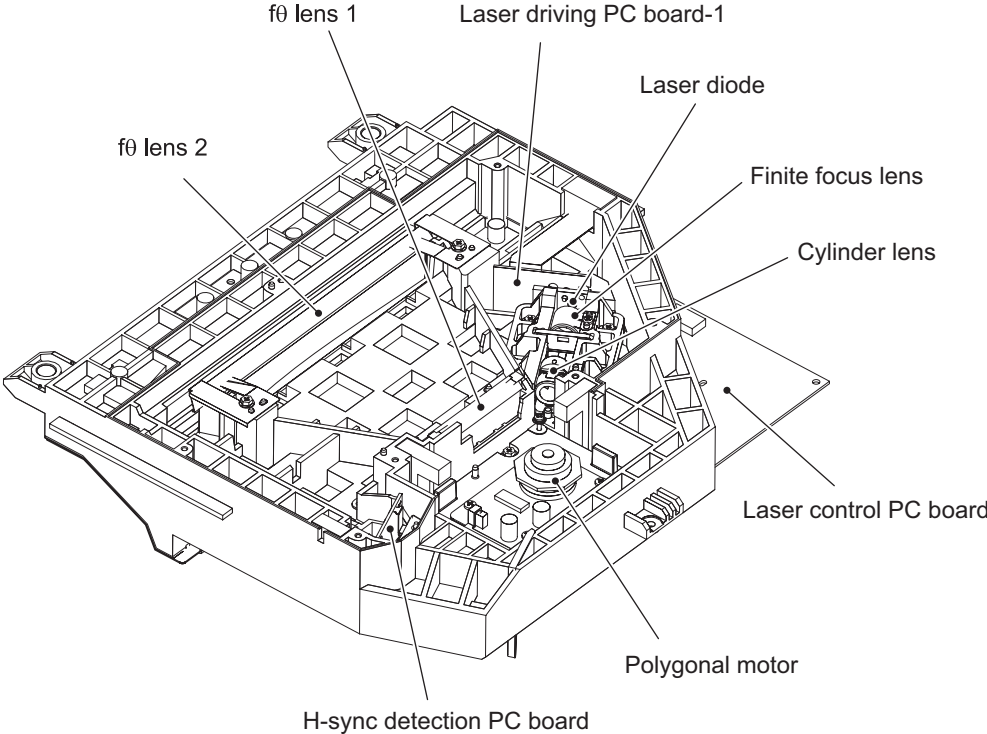
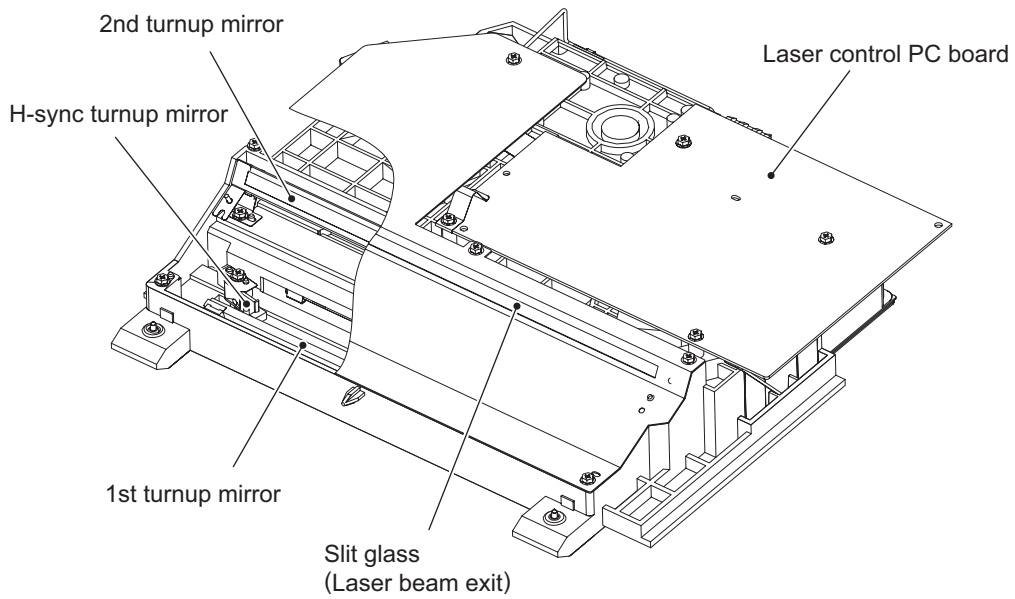
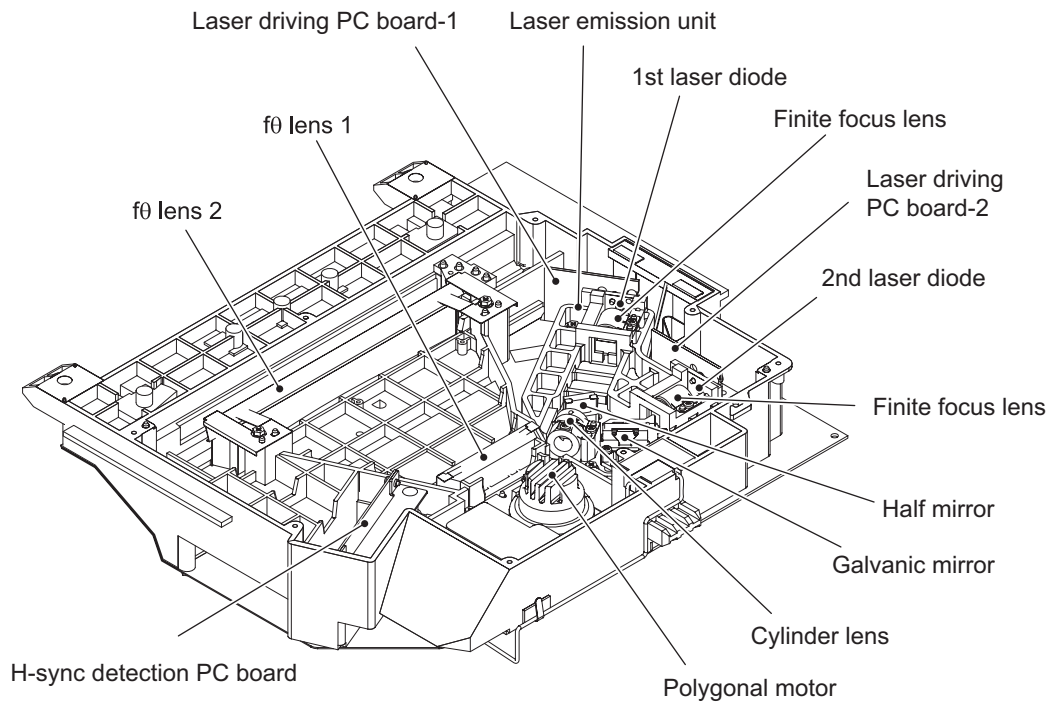

Fig. 7-1



[Laser optical unit overview]

Fig. 7-2



[Laser optical unit overview]

Fig. 7-3

7.2 Structure

7.2.1 Laser optical unit

This unit consists of the laser diode, finite focus lens, aperture, half mirror (*1), galvanic mirror (GLV) (*1) and cylinder lens.

* 1: Used for the e-STUDIO755/855 only

- Laser diode

This laser diode features low drooping, small laser variation and a low threshold current. The aperture determines the shape of the laser beam at the laser emission position. The laser diode radiates the laser beams responding to the laser emission control (ON/OFF) signals from the laser drive board. Laser beams which have passed through the finite focus lens are focused on the drum surface.

- Laser precautions

A laser diode is used for this equipment and radiates an invisible laser beam.

Since it is not visible, be extremely careful when handling the laser optical unit components, performing operations or adjusting the laser beam. Also never perform the procedure with other than the specified manuals because you could be exposed to the laser radiation.

The laser unit is completely sealed with a protective cover. As long as only the operations of specified manuals are performed, the laser beam is not leaked and you are in no danger of being exposed to laser radiation.

The following cautionary label for the laser is attached to the left side of the front-inner cover.

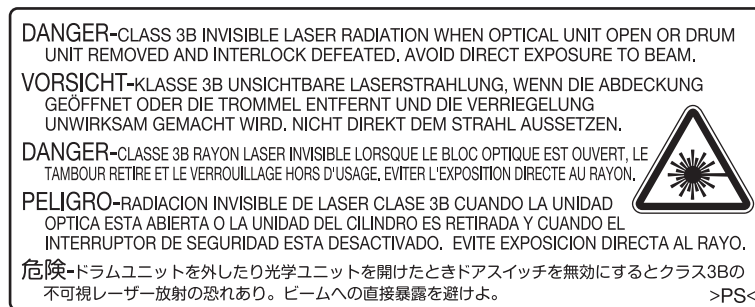

Fig. 7-4

- Avoid expose to laser beam during service. This equipment uses a laser diode. Be sure not to expose your eyes to the laser beam. Do not insert reflecting parts or tools such as a screwdriver on the laser beam path. Remove all reflecting metals such as watches, rings, etc. before starting service.
- When servicing the equipment with the power turned ON, be sure not to touch live sections and rotating/operating sections. Avoid exposing your eyes to laser beam.
- During servicing, be sure to check the rating plate and cautionary labels such as "Unplug the power cable during service", "CAUTION. HOT", "CAUTION. HIGH VOLTAGE", "CAUTION. LASER BEAM", etc. to see if there is any dirt on their surface and if they are properly stuck to the equipment.

- Laserdiode

Diese Laserdiode zeichnet sich durch eine geringe Regeldifferenz, eine kleine Laservariation und einen niedrigen Schwellenstrom aus.

Die Blende der Laseremissionseinheit ist unter dem Fokussierobjektiv angeordnet, um die Form der Laserstrahlen in der primären und sekundären Scanrichtung festzulegen.

Die Laserdiode gibt Laserstrahlen als Reaktion auf die Signale der Laseremissionssteuerung (ein/aus) von der Lasertreiber-PC-Platine (LDR) aus. Die durch das Fokussierobjektiv geführten Laserstrahlen werden auf die Trommeloberfläche fokussiert.

- Vorsichtsmaßnahmen im Zusammenhang mit Lasern

Dieses Gerät enthält eine Laserdiode, die einen unsichtbaren Laserstrahl emittiert.

Da man diesen Laserstrahl nicht sehen kann, ist bei der Handhabung der Komponenten der optischen Lasereinheit, bei der Durchführung von Arbeiten und bei der Justierung des Laserstrahls äußerste Vorsicht geboten. Arbeiten dürfen niemals anhand anderer als den vorgeschriebenen Anleitungen durchgeführt werden; andernfalls kann es zu einer Schädigung Exposition durch Laserstrahlung kommen.

Die Lasereinheit ist vollständig mit einer Schutzabdeckung versiegelt. Solange ausschließlich die Arbeitsschritte der vorgeschriebenen Anleitungen durchgeführt werden, tritt der Laserstrahl nicht aus, und es besteht keine Gefahr, der Laserstrahlung ausgesetzt zu werden.

Das folgende Laser-Warnetikett ist an der Abdeckung links angebracht (innerhalb der vorderen Abdeckung).

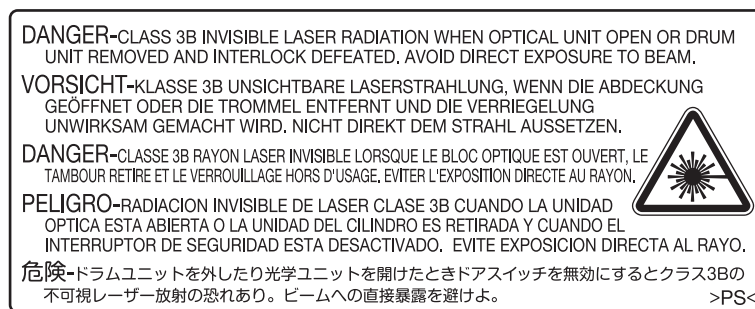

Fig. 7-5

Warnhinweise:

- Setzen Sie sich während der Wartungsarbeiten nicht dem Laserstrahl aus.
Dieses Gerät ist mit einer Laserdiode ausgestattet. Es ist unbedingt zu vermeiden, direkt in den Laserstrahl zu blicken. Keine reflektierenden Teile oder Werkzeuge, wie z. B. Schraubendreher, in den Pfad des Laserstrahls halten. Vor den Wartungsarbeiten sämtliche reflektierenden Metallgegenstände, wie Uhren, Ringe usw., entfernen.
- Bei Wartungsarbeiten am eingeschalteten Gerät dürfen keine unter Strom stehenden, drehbaren oder betriebsrelevanten Bereiche berührt werden. Nicht direkt in den Laserstrahl blicken.
- Im Rahmen der Wartung unbedingt das Leistungsschild und die Etiketten mit Warnhinweisen überprüfen [z. B. „Unplug the power cable during service“ („Netz Kabel vor Beginn der Wartungsarbeiten abziehen“), „CAUTION. HOT“ („VORSICHT, HEISS“), „CAUTION. HIGH VOLTAGE“ („VORSICHT, HOCHSPANNUNG“), „CAUTION. LASER BEAM“ („VORSICHT, LASER“) usw.], um sicherzustellen, dass sie nicht verschmutzt sind und korrekt am Gerät angebracht sind.

7.2.2 Polygonal motor unit

This unit consists of the polygonal motor (M2), polygonal mirror and polygonal mirror cover.

a. Polygonal motor

This motor rotates the polygonal mirror at a high speed. The DC motor controls the rotation speed of the motor.

b. Polygonal mirror

The e-STUDIO555/655 has a 1-beam type of laser unit. One laser beam emitted from the laser diode is reflected by this mirror. As the polygonal mirror is rotated by the polygonal motor (M2), the reflected laser beam moves in sync with the rotation. The direction of the movement is the primary scanning direction of the image. One scan is performed on 1 plane of the polygonal mirror. As the polygonal mirror has 8 planes, 8 scans are performed in 1 rotation.

e-STUDIO755/855 has a 2-beam type of laser unit. Two laser beams emitted from the laser diode are reflected by this mirror. Two scans are performed on 1 plane of the polygonal mirror. As the polygonal mirror has 8 planes, 16 scans are performed in 1 rotation.

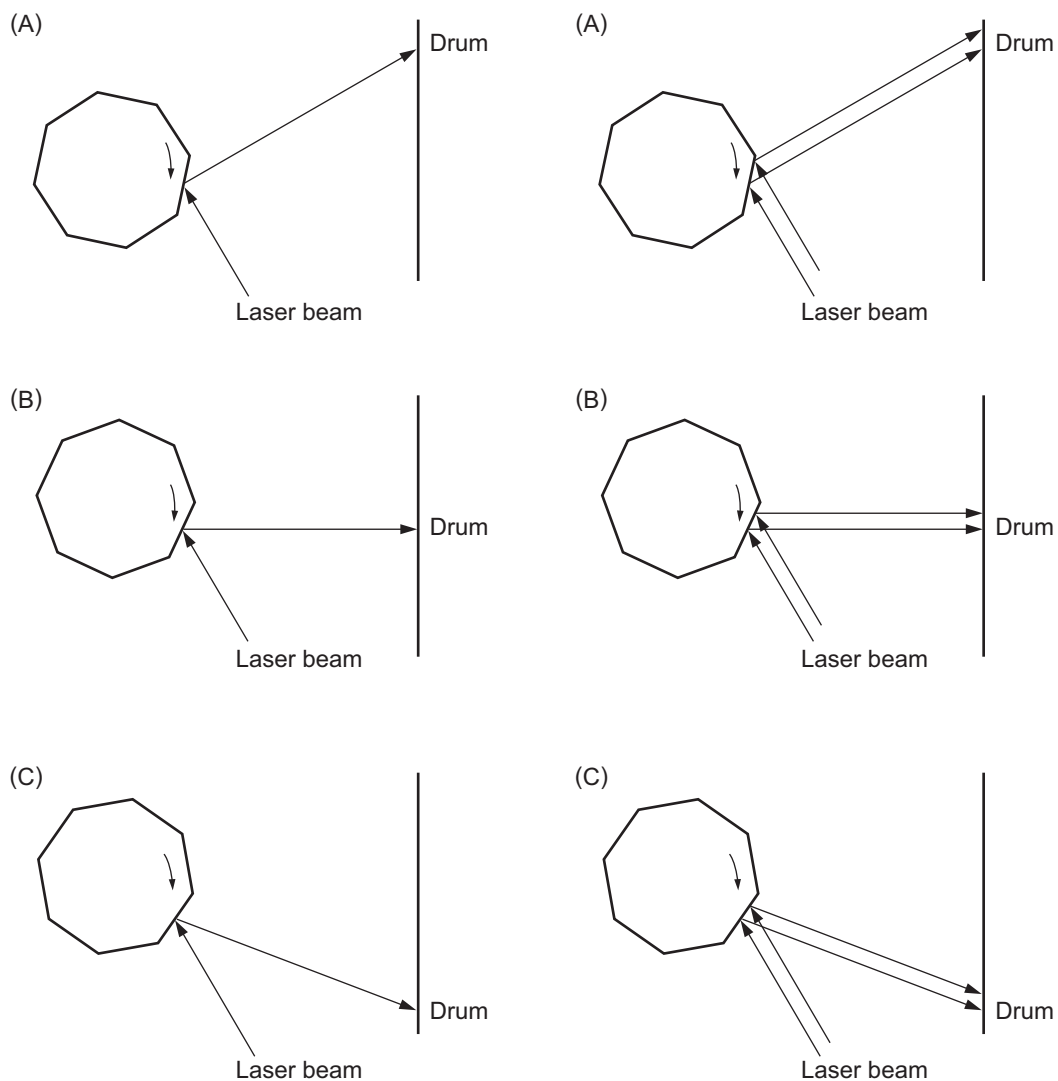

Fig. 7-6

[e-STUDIO555/655]

One scan is completed by completion of steps (A) to (C). One scan is performed on one plane of the polygonal mirror. Eight scans can be made with one rotation of the polygonal mirror.

[e-STUDIO755/855]

Two scan is completed by completion of steps (A) to (C). Two scan is performed on one plane of the polygonal mirror. Sixteen scans can be made with one rotation of the polygonal mirror.

c. Polygonal mirror cover

The polygonal mirror cover reduces wind damage and noise, prevents adhesion of foreign matter on the mirror surface and releases heat by sealing the polygonal mirror.

7.2.3 $f\theta$ lenses 1 and 2

These two lenses perform the following adjustment on the laser beams reflected by the polygonal mirror.

a. Uniform-velocity scanning

Since the polygonal mirror is rotating at a uniform velocity, the laser beam reflected from the mirror scans over the drum surface at a uniform angular velocity; namely, the pitch between the dots on the drum is wider at both ends than at the center of the scanning range. The $f\theta$ lenses help to correct this difference, making all the dot-to-dot pitches equal on the drum surface.

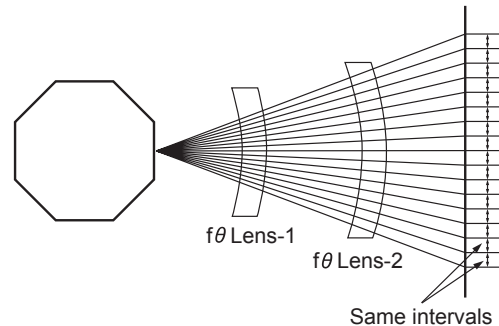
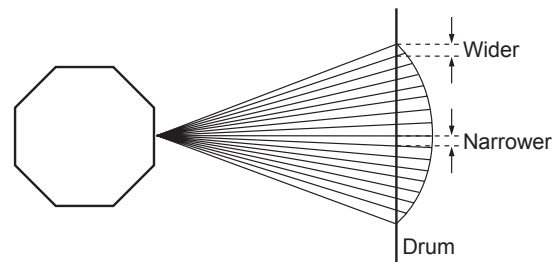

Fig. 7-7

b. Face tilt connection

The reflecting face of the polygonal mirror is tilted slightly to one side against the perfect vertical. Horizontal deviation of the laser beam which is caused by the tilt is corrected.

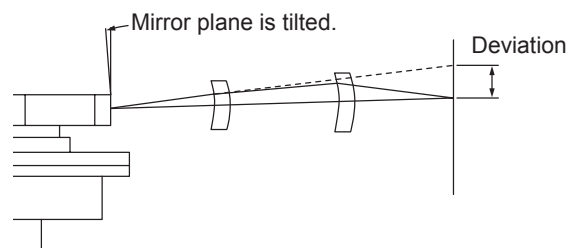

Fig. 7-8

c. Sectional shape of laser beam

The shape of the laser beam spotted on the drum is adjusted.

7.2.4 H-sync detection PC board (SNS board)

Laser beam which has started to be scanned from one of the reflected faces of the polygonal mirror is reflected by the H-sync detection mirror and goes into the PIN diode on the H-sync detection PC board (SNS). The primary scanning synchronizing signal is generated based on this reflected laser beam. For the e-STUDIO755/855, the rudder sensor is attached to the H-sync sensor to space out evenly (42.3 μm), the intervals of the secondary scanning of the 1st and 2nd beams by its detection value.

7.2.5 Laser driving board (LDR1/LDR2 board)

This control board has the following functions:

- APC control function (adjusts disparity of the laser intensity caused by temperature)
- Laser ON/OFF function

7.2.6 Slit glass

Slit glass is located where the laser beams are output from the laser optical unit, and it protects the unit from dust.

7.3 Laser Diode Control Circuit

This equipment uses an AlGaAs type semiconductive laser with 10 mW of optical output power rating. This laser emits a beam in a single transverse mode in approx. 785 nm wavelength. PIN diode for monitoring optical output in this laser controls the laser intensity.

The relation between the forward current and optical output of a semiconductive laser is as shown below. Beam emission starts when the forward current exceeds a threshold current, and then the laser outputs a monitor current which is proportionate to the optical output. Since semiconductive lasers have an individual variability in their threshold current and monitor current, the optical output needs an adjustment to be maintained at a certain value.

The optical output of a semiconductive laser decreases as the laser temperature rises. Therefore APC (Auto Power Control) needs to be performed to maintain a constant optical output.

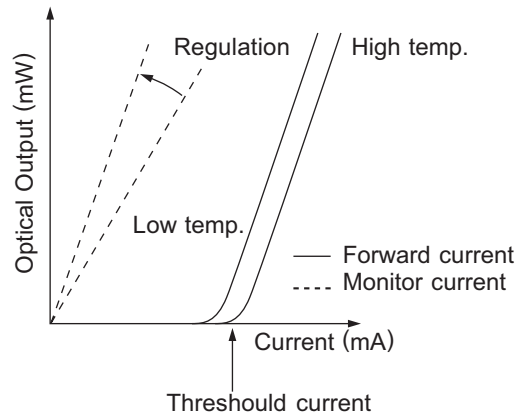

Fig. 7-9

A block diagram of the semiconductive laser control circuit is shown below. The semiconductive laser performs a monitor efficiency regulation (a process to control a monitor current for beam emission amount). The initial beam emission is adjusted.

The voltage of the monitor output, which has been regulated by this adjustment, is then fed back to a laser power comparison circuit.

In the laser power comparison circuit, this voltage fed back and a laser power voltage set for the control circuit are compared for every scanning. As the result of this, a laser driver circuit increases its forward current when the laser power is insufficient and decreases it when the laser power is excessive to maintain a constant optical output.

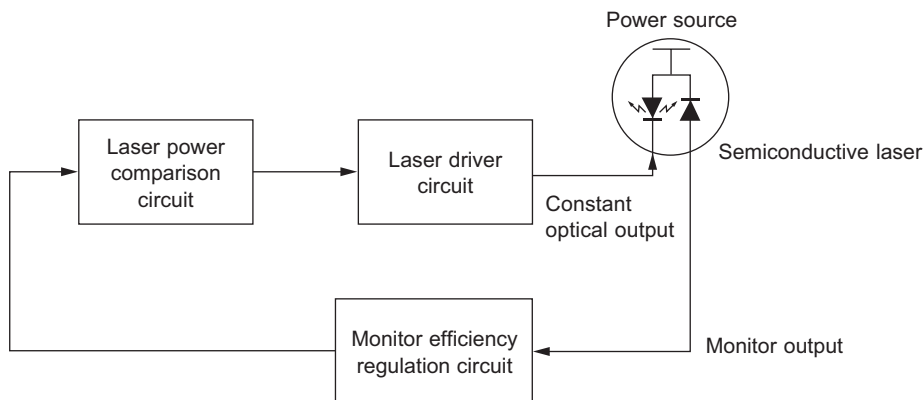

Fig. 7-10

7.4 Polygonal Motor Control Circuit

The polygonal motor is a DC motor rotated by a clock signal (PMCLK-1) output from the Laser-CPU. This motor is controlled under PLL (Phase Locked Loop) to realize an accurate and constant rotation. Its rotation status is converted to a status signal (PMOK-0) and then output to the Laser-CPU. PMOK-0 signal moves to a low level only when the rotation status of the motor is constant. The Laser-CPU detects the rotation status with this signal, and emits a laser beam only when the rotation status is constant.

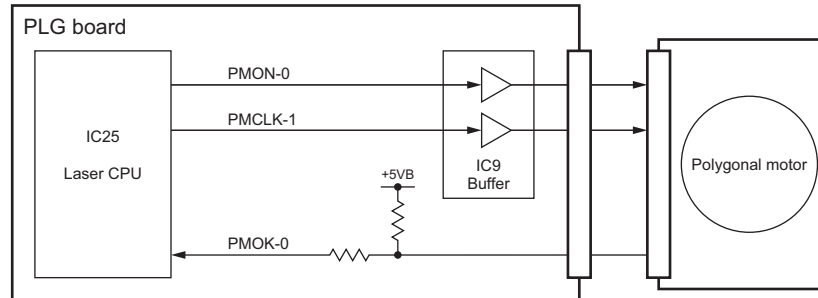

Fig. 7-11

Signal	Function	Low level	High level
PMON-0	Polygonal motor ON signal	ON	OFF
PMCLK-1	Polygonal motor reference clock	-	-
PMOK-0	Polygonal motor PLL control signal	Rotating at a constant speed	Stopping or error

7.5 Laser Unit Cooling Fan Control Circuit

The laser unit cooling fan is a DC fan motor which sends air to the laser unit heated by the polygonal motor to cool down the unit. This fan is controlled to switch its rotation among three; high speed, low speed and stopping, according to the condition of the equipment.

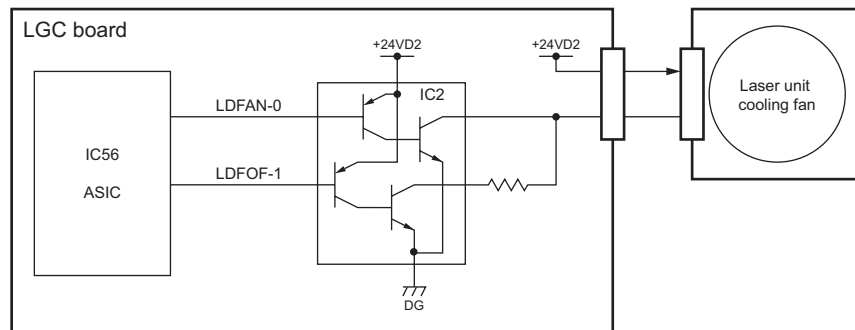

Fig. 7-12





Signal	Function
LDFAN-0	Laser unit cooling fan high-speed rotation signal
LDFOF-1	Laser unit cooling fan low-speed rotation signal

Relation between each signal level and the rotation of the fan
(L = Low level, H = High level)

LDFOF-1	LDFAN-0	Rotation of Fan
L	L	High speed
H	L	
L	H	Low speed
H	H	Stopping

7.6 Disassembly and Replacement

[A] Laser unit cooling fan

- (1) Take off the top right cover, right upper cover, right center cover and right rear cover.
( P.2-42 "[C] Top right cover",
 P.2-43 "[F] Right upper cover",
 P.2-43 "[G] Right center cover",
 P.2-43 "[H] Right rear cover")
- (2) Remove 1 screw, loosen 9 screws and take off the plate cover.

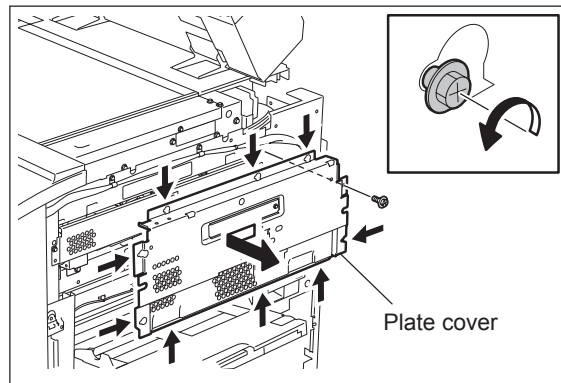

Fig. 7-13

- (3) Remove 1 screw fixing the Laser unit.
(Not required for e-STUDIO755/855)
- (4) Remove 2 screws and take off the laser unit fixing stay.

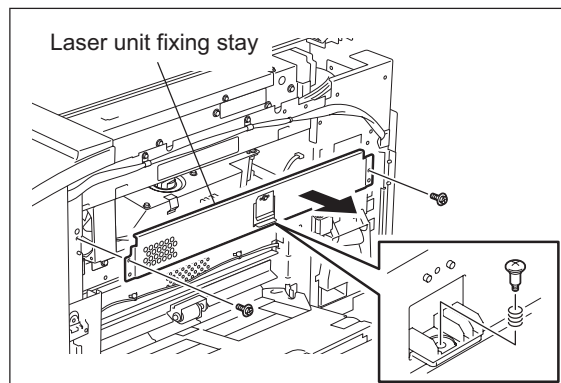

Fig. 7-14

- (5) Disconnect 1 connector and remove 2 screws to take off the laser unit cooling fan.

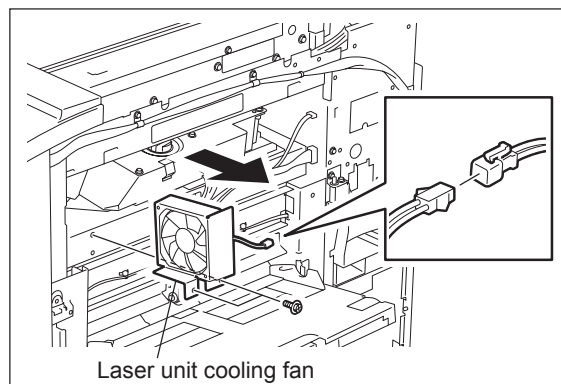



Fig. 7-15

[B] Laser optical unit

- (1) Remove the laser unit cooling fan.
( P.7-12 "[A] Laser unit cooling fan")
- (2) Remove one screw and take off the Leaf spring.

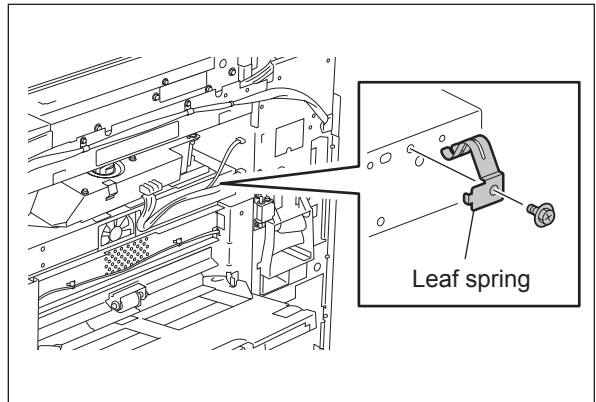



Fig. 7-16

[B-1] e-STUDIO755/855

- (1) Remove the original glass.
( P.6-13 "[A] Original glass")
- (2) Loosen 2 laser unit setscrews.

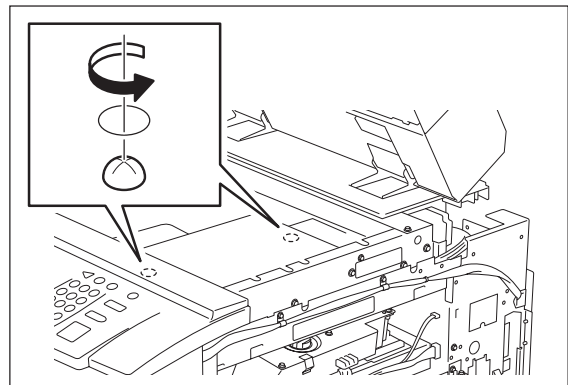

Fig. 7-17

- (3) Disconnect 2 connectors and pull out the laser unit.

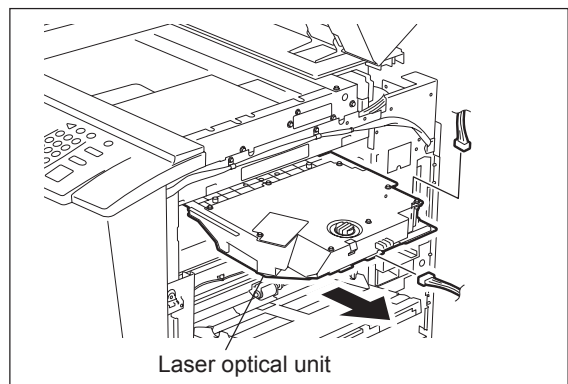

Fig. 7-18

[B-2] e-STUDIO555/655

- (1) Disconnect 2 connectors and pull out the laser unit.

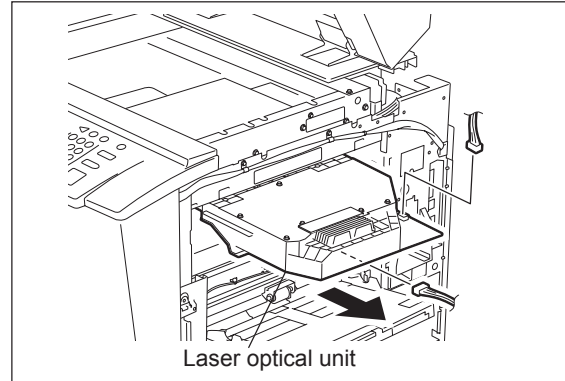



Fig. 7-19

[C] Laser control PC board (PLG board)

- (1) Remove the laser optical unit.
( P.7-13 "[B] Laser optical unit")
- (2) Disconnect 3 connectors.
(e-STUDIO755/855: 5 connectors)
- (3) Remove 4 screws and take off the Laser control PC board (PLG board).

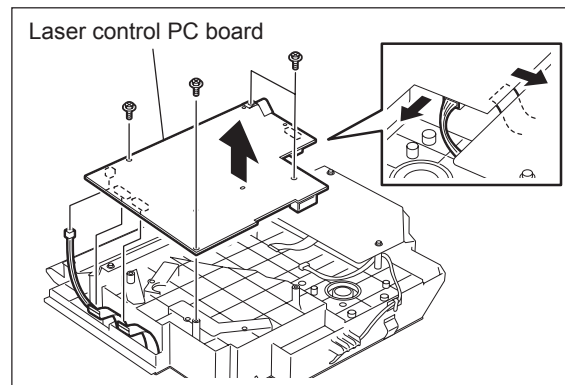

Fig. 7-20

Notes:

1. Do not leave fingerprints or stain on the slit glass.
2. Pay close attention not to make an impact or vibration on the laser optical unit because it is a precise apparatus.
3. Place the removed laser optical unit so as not to load on the polygonal motor.
4. Do not disassemble the laser optical unit in the field because it is precisely adjusted and very sensitive to dust and stain.

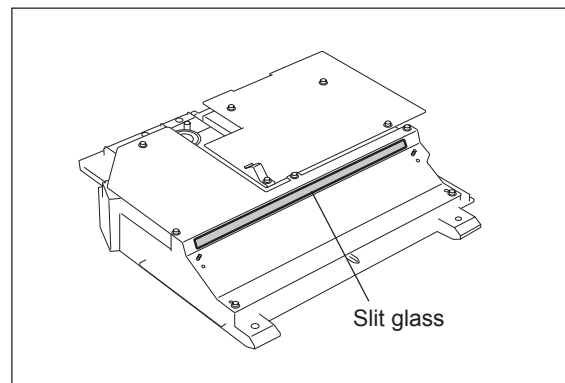

Fig. 7-21

8. PAPER FEEDING SYSTEM

8.1 General Description

This unit picks up a sheet of paper from the drawer, tandem LCF or bypass tray and transports it to the transfer position.

The clutch controls the drive from the motor and drives each roller. Also, each sensor detects the transferring status of the sheet of paper. Fig. 9-1 shows the positioning of each roller and sensor from the first drawer to the registration roller. Fig. 9-2 shows the positioning of each roller and the sensor of the tandem LCF.

Moreover, the composition of the paper feeding unit differs depending on the destination (machine version). The 4-drawer composition is for JPC. The composition of the 2 drawers and tandem LCF is for other destinations.

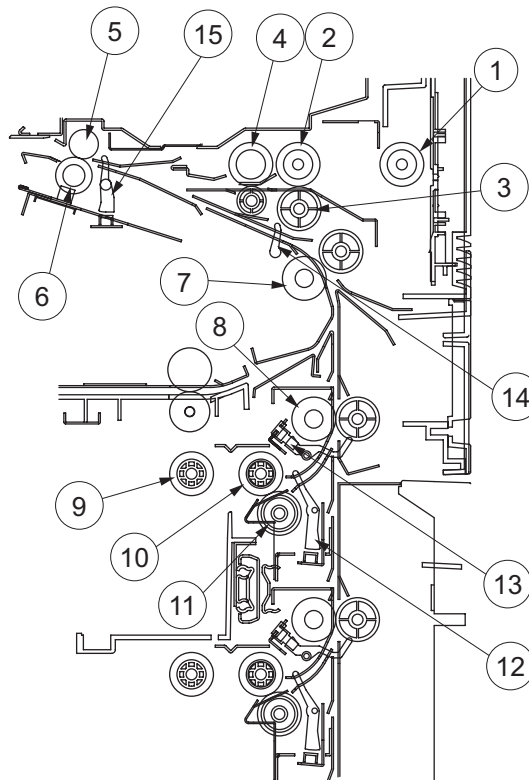

Fig. 8-1

No.	Name	No.	Name
1	Bypass pickup roller	9	Drawer pickup roller
2	Bypass feed roller	10	Drawer feed roller
3	Bypass separation roller	11	Drawer separation roller
4	Bypass transport roller	12	Drawer feed sensor
5	Registration roller (metal)	13	Drawer transport sensor
6	Registration roller (rubber)	14	Intermediate transport sensor
7	Intermediate transport roller	15	Registration sensor
8	Transport roller	—	

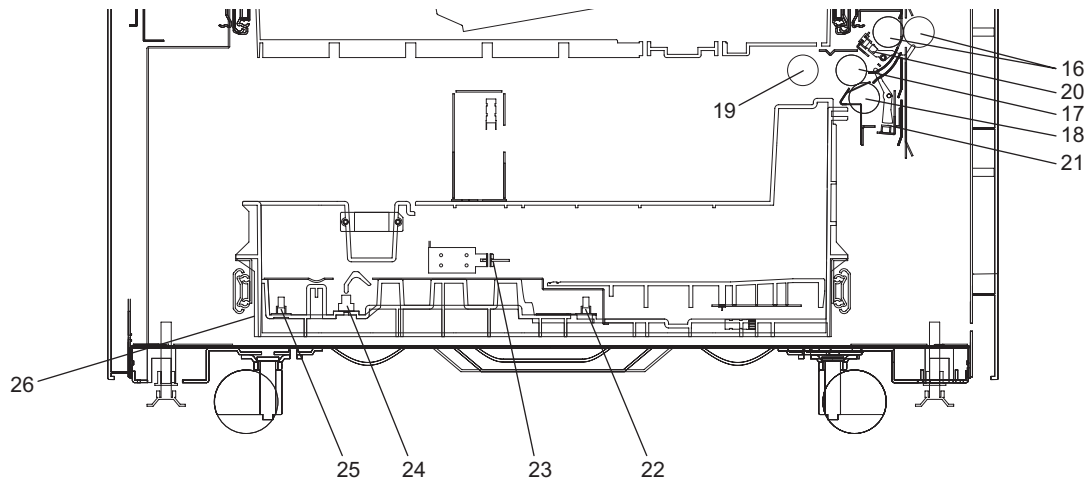

Fig. 8-2

No.	Name	No.	Name
16	3rd drawer transport roller / Tandem LCF transport roller	22	End fence stop position sensor
17	3rd drawer feed roller / Tandem LCF feed roller	23	Standby side mis-stacking sensor
18	3rd drawer separation roller / Tandem LCF separation roller	24	Standby side empty sensor
19	3rd drawer pickup roller / Tandem LCF pickup roller	25	End fence home position sensor
20	3rd drawer transport sensor	26	Tandem LCF
21	3rd drawer feed sensor	—	

8.2 Functions

1. Pickup roller
These rollers draw out paper from the bypass tray, drawer or tandem LCF and send it to the feed roller.
2. Feed roller
This roller is placed against the separation roller. It transports paper from the pickup roller to the transport roller.
3. Separation roller
This roller is placed against the feed roller. When two or more sheets of paper are sent from the pickup roller, the load of the torque limiter of the separation roller is greater than the frictional force between the sheets of paper. As the result, the separation roller is stopped and the lower paper is not advanced any further. When only one sheet of paper is sent from the pickup roller, the separation roller rotates following the feed roller.
4. Transport roller
This roller transports the paper sent from the feed roller to the intermediate transport roller.
5. Intermediate transport roller
This roller transports the paper sent from the transport roller to the registration roller.
6. Registration roller
The paper sent from the intermediate transport roller is pushed against the registration roller which aligns the leading edge of paper. Then the registration roller rotates to transport the paper to the transfer section.
7. Bypass feed sensor (S27)
This sensor detects if paper is set in the bypass tray. If it is, bypass feeding always comes before drawer feeding.
8. Empty sensor (S31, S37, S43, S49)
This is an emission type sensor and detects the availability of paper in the drawer by using an actuator. When there is no paper in the drawer, the actuator blocks the light path of the sensor, and the sensor determines that there is no paper.
9. Feed sensor (S34, S40, S46, S52), Transport sensor (S33, S39, S45, S51)
Feed sensor (S34, 40, 46, 52) detects if the leading edge or trailing edge of paper passed the feed roller. Transport sensor (S33, 39, 45, 51) detects if the leading edge or trailing edge of paper passed the transport roller. They also detects jams like misfeeding.
10. Registration sensor (S18)
This sensor detects that the leading edge of paper has reached the registration roller and the trailing edge of paper has passed the registration roller.
11. Drawer / tandem LCF tray-up sensor (S32, S36, S42, S48)
This sensor detects the tray position when the trays of the drawer and tandem LCF go up. It detects the amount of sheets placed in the drawer according to the time between when the drawer bottom sensor (S30, 36, 42, 48) is turned OFF and the drawer tray-up sensor (S32, 38, 44, 50) is turned ON.
12. Drawer bottom sensor (S30, S36, S42, S48)
This sensor detects the tray bottom position of the drawer.
13. Tandem LCF tray bottom sensor (S71)
It detects the lower limit position (home position) on the LCF tray.

14. Standby side mis-stacking sensor (S72)

It detects if sheets of paper placed in the feeding side tray or standby side tray are not within the tray (sheets are not aligned correctly).

15. End fence home position sensor (S73)

It detects the end fence home position.

16. Standby side empty sensor (S74)

It detects the presence/absence of a sheet of paper on the standby side tray.

17. End fence stop position sensor (S75)

The tandem LCF end fence motor (M42) drives the end fence. The end fence pushes a sheet of paper placed on the standby side tray, and moves it to the feeding side tray. The end fence stop position sensor (S75) detects the stopping position of the end fence so that the sheet is not pushed too much.

8.3 Operation

8.3.1 Operation of bypass pickup roller

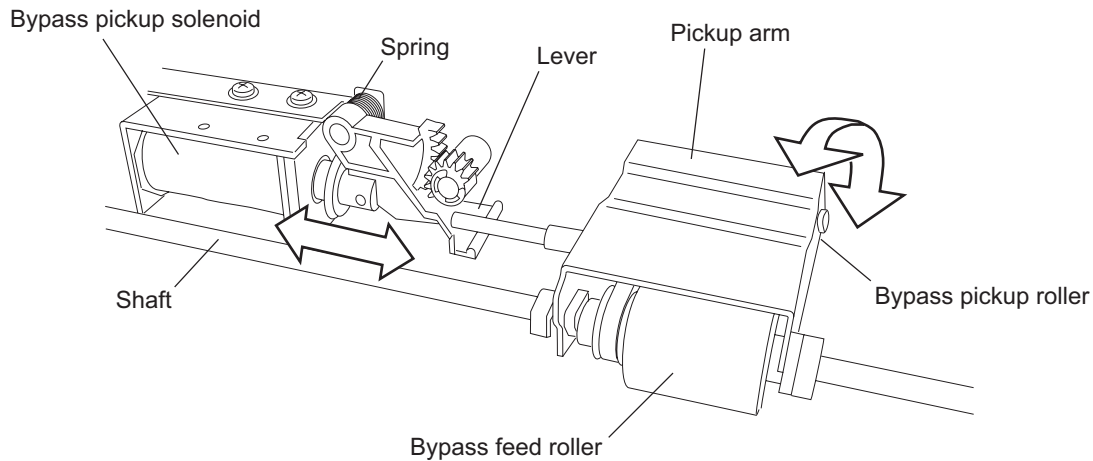

Fig. 8-3

When the bypass pickup solenoid (SOL3) is turned ON, the plunger is pulled and the lever is revolved and brought down. The pickup arm, which is linked with the lever, is also brought with the lever by its own weight. When the bypass pickup solenoid (SOL3) is turned OFF, the pickup arm is brought up by the spring force.

The driving force transmitted through the bypass feed clutch (CLT4) is also transmitted to the bypass feed roller through the shaft and then to the bypass pickup roller through the timing belt. The roller is rotated by this driving force.

8.3.2 Operation of drawer pickup roller

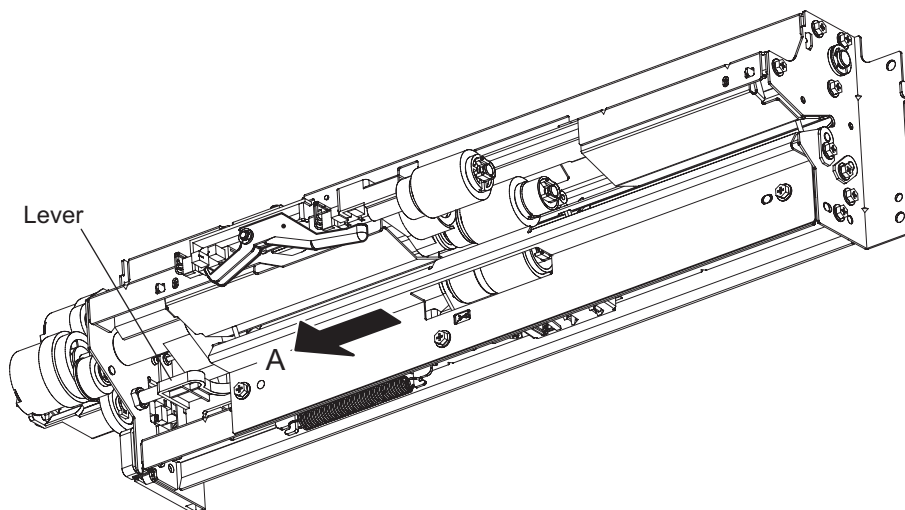

Fig. 8-4

When the drawer is inserted, the protrusion at the rear side of the drawer pushes the lever to the direction of A. Then the pickup roller and roller holder are lowered by the spring force.

8.3.3 Paper separation

This model is equipped with a separation roller which works to prevent multiple paper feeding. The separation roller unit consists of the feed roller, separation roller, torque limiter, etc., as shown at right. The feed roller is rotated by the feed clutch in the direction of the white arrow at the same timing as the pickup roller rotation.

The figure at right shows how duplicate feeding is prevented: Since the friction between two sheets is small, the lower sheet is not transported any further while the upper sheet is transported by the feed roller in the direction of the black arrow.

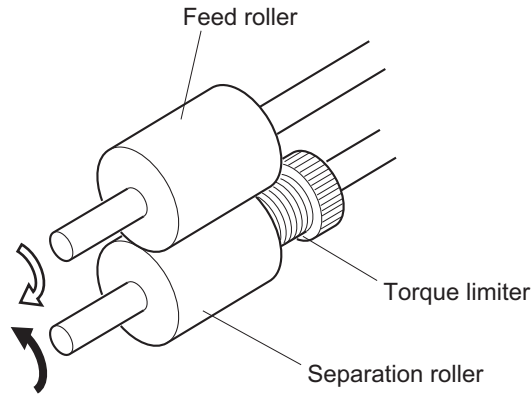

Fig. 8-5

[Example]

When only one sheet enters between the rollers:

Since the transporting force of the feed roller is greater than the braking force of the separation roller, the separation roller follows the feed roller, making the sheet go forward to the registration roller.

When two sheets enter between the rollers at the same time:

Since the transporting force of the feed roller and the braking force of the separation roller are greater than the frictional force between two sheets, the paper A is transported to the direction of the black arrow and the paper B is braked by the separation roller and is not transported any further.

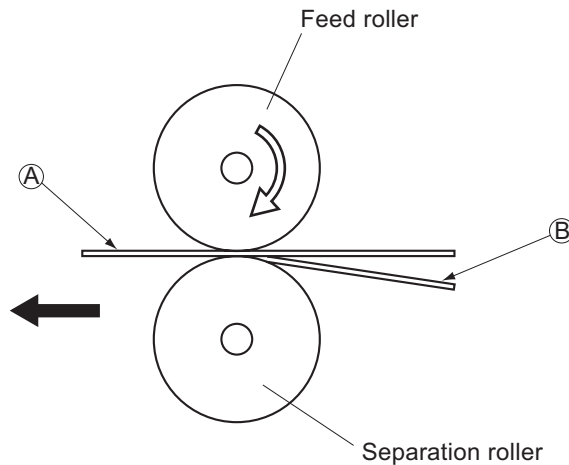
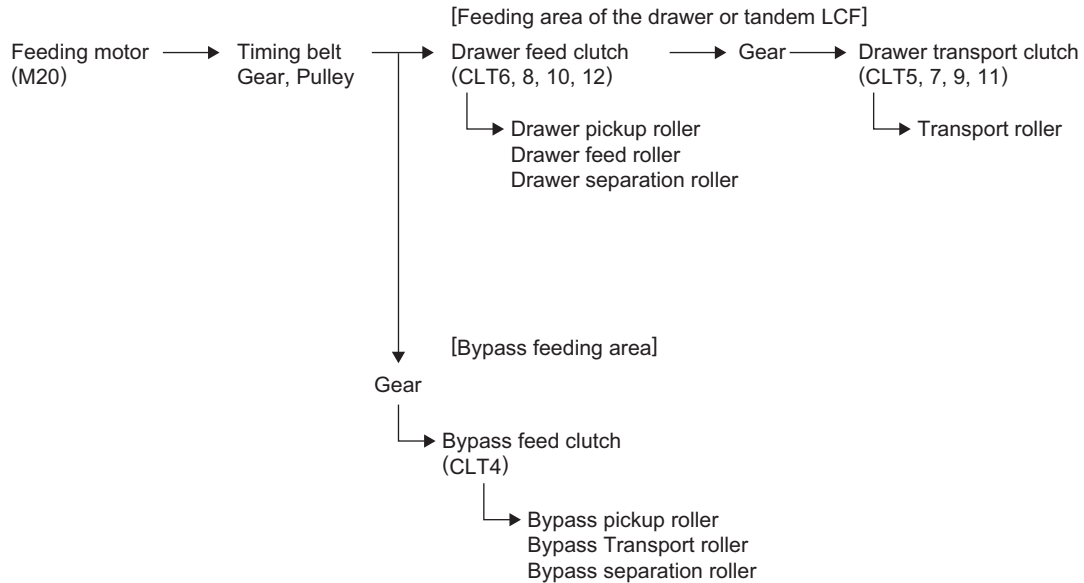

Fig. 8-6

8.3.4 Driving

The drive of each motor in the paper feeding area activates the paper transfer roller as follows.



Registration motor (M16) → Timing belt Pulley → Registration roller

Transport motor (M17) → Timing belt Pulley → Intermediate transport roller

Tray-up motor-1 (M21) → Tray in the first and second drawer

Tray-up motor-2 (M22) (* For JPC model) → Tray in the third and fourth drawer

Tandem LCF Tray-up motor (M41) (* Except for JPC model) → Tray of the Tandem LCF

Tandem LCF end fence motor (M42) (* Except for JPC model) → Gear, Timing belt → End fence

8.3.5 General operation

[A] From power ON to standby status

- (1) When the equipment is turned ON, the tray-up motor-1 (M21) is activated and 1st drawer tray starts to rise. When the 1st drawer tray-up sensor (S32) is turned ON (H -> L), the tray-up motor-1 (M21) is turned OFF and the tray is stopped. At this time, if the 1st drawer empty sensor (S31) is OFF (L), it is judged that there is no paper in the drawer. With the 1st drawer empty sensor (S31) being ON (H), there is paper in the drawer. The tray stops at the raised position regardless of availability of paper. Then the tray-up motor-1 (M21) starts to rotate in reverse and 2nd drawer starts to be lifted. 2nd drawer tray is stopped in the same manner as 1st drawer tray and the 1st drawer empty sensor (S31) detects if there is paper in the drawer.
- (2) When the drawer is not completely inserted when the equipment is turned ON, the tray for that drawer tray is not raised. When the drawer is inserted completely, the drawer tray is raised and checks the availability of the paper.
- (3) When either of the sensors at the transport path is ON (meaning there is paper on the transport path) when the equipment is turned ON, it is determined that a paper jam has occurred and no operation is enabled until the paper is removed.

[B] Standby status

- (1) After the drawer tray is moved up and availability of paper is checked as described above, the equipment enters the standby state. In the standby mode, the drawer tray remains at raised position.
- (2) When a drawer is inserted or removed in the standby state, the tray is raised again to check the availability of paper.

[C] Bypass feeding

- The bypass feed sensor (S27) detects the availability of paper.
- The bypass feed clutch (CLT4) is turned ON and the bypass pickup roller and bypass feed roller rotate.
- The bypass pickup solenoid (SOL3) is turned ON and the bypass pickup roller is lowered to start feeding.
- The leading edge of the paper turns ON the registration sensor (S18) and the paper is aligned with the registration roller.
- The bypass feed clutch (CLT4) is turned OFF and the bypass pickup roller and the bypass feed roller are stopped, and then the bypass pickup roller is raised.
- The registration motor (M16) is turned ON and paper is transported to the transfer unit.

[D] Drawer feeding

- The feed clutch (CLT6, 8) is turned ON and the pickup roller and feed roller rotate to start feeding.
- The leading edge of paper turns ON the transport sensor (S33, 39, 45, 51), the feed clutch (CLT6, 8) is turned OFF and the transport clutch (CLT5, 7) is turned ON.
- The leading edge of paper turns ON the registration sensor (S18) and paper is aligned with the registration roller.
- The transport clutch (CLT5, 7) is turned OFF and the transport roller is stopped.
- The registration motor (M16) and transport clutch (CLT5, 7) are turned ON and paper is transported to the transfer unit.

8.3.6 Description of Tandem LCF Operation

[A] After power is ON to ready

- (1) When the equipment is turned ON, the pre-running operation at warming up is started. The tandem LCF tray-up motor (M41) starts to rotate forward and raises the feeding side tray. When the tray turns ON the tandem LCF tray-up sensor (S44), the tandem LCF tray-up motor (M41) is turned OFF, and then the tray is stopped. At this time, when the tandem LCF empty sensor (S43) is ON, it is judged that there is paper in the feeding side tray. On the other hand, the absence of paper in the feeding side tray is assumed when the tandem LCF empty sensor (S43) is OFF, and the standby side empty sensor (S74) is subsequently checked. When the standby side empty sensor (S74) is OFF, that means there is no paper in the standby side tray, and it is therefore assumed that there is no paper in the tandem LCF. When the standby side empty sensor (S74) is ON, the paper in the standby side tray is moved to the feeding side tray. The tandem LCF tray-up motor (M41) is rotated in reverse and lowers the feeding side tray. The lowered tray turns ON the tandem LCF bottom sensor (S71), and the tandem LCF tray-up motor (M41) is turned OFF to stop the tray. The tandem LCF end fence solenoid (SOL8) and tandem LCF pickup solenoid (SOL7) are then turned ON. The tandem LCF end fence motor (M42) rotates forward and the paper in the standby side tray is moved onto the tray of the feeding side. The tandem LCF end fence motor (M42) is stopped for a second when the end fence stop position sensor (S75) is turned ON, and the motor (M42) immediately starts to rotate in reverse to return the end fence to the position where the end fence home position sensor (S73) is turned ON. When the returning operation is started, the tandem LCF end fence solenoid (SOL8) and tandem LCF pickup solenoid (SOL7) are turned OFF, and the tandem LCF tray-up motor (M41) is rotated forward to raise the feeding side tray. The tandem LCF tray-up motor (M41) is turned OFF when the tray being raised turns ON the tandem LCF tray-up sensor (S44) and stops the tray. At this time, the presence of paper is judged when the tandem LCF empty sensor (S43) is ON.
- (2) If the power is turned ON when the drawer has been removed, the tray raising movement is not operated. The tray is raised as soon as the drawer is installed, and it detects if there is paper in the drawer.
- (3) If either of the tandem LCF feed sensors (S46) is ON (paper remains on the transport path) when the power is turned ON, that means a paper jam has occurred and the operation is disabled until the paper is removed.

[B] Ready status

- (1) Trays detect the paper as described in [A], and the equipment goes into the ready status.
- (2) The tray goes down automatically when the drawer is removed. It is raised as soon as the drawer is reinstalled and checks if there is paper in the drawer.

[C] From the start to the end of printing

- (1) The feed motor (M20) starts driving when the [START] button is pressed.
- (2) When the equipment judges that the tandem LCF is ready for feeding paper, it turns ON the tandem LCF feed clutch (CLT10). This clutch drives the pickup roller and feed roller to feed paper from the tray.
- (3) The tandem LCF transport clutch (CLT9) is turned ON to drive the transport roller when the specified period of time has passed from the start of feeding.
- (4) When the leading edge of the paper turns the tandem LCF feed sensor (S46) ON, the tandem LCF feed clutch (CLT10) is turned OFF and feeding from the tandem LCF is completed.
- (5) The paper is transported by the transport roller. If the trailing edge of the sheet previously transported still remains at the 2nd drawer transport sensor (S39) when the leading edge of the paper reaches the tandem LCF feed sensor (S46), the tandem LCF transport clutch (CLT9) is turned OFF to stop the transport of the paper.
- (6) When the trailing edge of the paper turns the tandem LCF feed sensor (S46) OFF, the tandem LCF then becomes ready for feeding the next sheet of paper, and the procedures (2) to (5) are repeated for the number of the printout.
- (7) When printing is completed, the feed motor (M20) is turned OFF.

[D] Jam detection

- (1) A paper jam occurs in the following cases.
 - Tandem LCF feed sensor (S46) is not turned ON within a specified period of time after the feeding is started.
 - The leading edge of the paper does not pass the tandem LCF feed sensor (S46) in the transport path within a specified period of time.
- (2) Open the right lower cover, remove all the paper remaining on the transport path and close the cover to clear the paper jam. If either of the tandem LCF transport sensor (S45) is still ON when the right lower cover is closed, it is determined that there is still paper on the transport path and the paper jam status is not cleared.
- (3) When a paper jam occurs in the tandem LCF during continuous copying, the sheet that was fed before the jam is copied normally.

[E] Call for Service

- (1) When the tandem LCF tray-up sensor (S44) is not turned ON even though the specified period of time has passed since the tray started to be raised, it is assumed that the drawer is not operational and the corresponding message is displayed on the control panel.
- (2) When the tandem LCF bottom sensor (S42) is not turned ON even though the specified period of time has passed since the tray started to be lowered, it is assumed that the drawer is not operational and the corresponding message is displayed on the control panel.
- (3) When the end fence stop position sensor (S75) is not turned ON even though the specified period of time has passed since the end fence started to move the paper in the standby side tray, it is assumed that the tandem LCF is not operational and the corresponding message is displayed on the control panel.
- (4) When the end fence home position sensor (S73) is not turned ON even though the specified period of time has passed since the end fence started to move the paper in the standby side, it is assumed that the tandem LCF is not operational and the corresponding message is displayed on the control panel.
- (5) The states (1) to (4) are cleared by turning the power OFF and solving the problems.

8.4 Tray-up motor control circuit

The tray-up motor is a DC motor driven by the control signal output from the PFC CPU on the LGC board and moves up the tray in each drawer.

The motor driver outputs the drive signal (PUTRM-0/1A, PLTRM-0/1A) to the motor based on the control signal (PUTRM-0/1, PLTRM-0/1). The motor operates the forward rotation, reverse rotation, brake or stop according to the status of these drive signals.

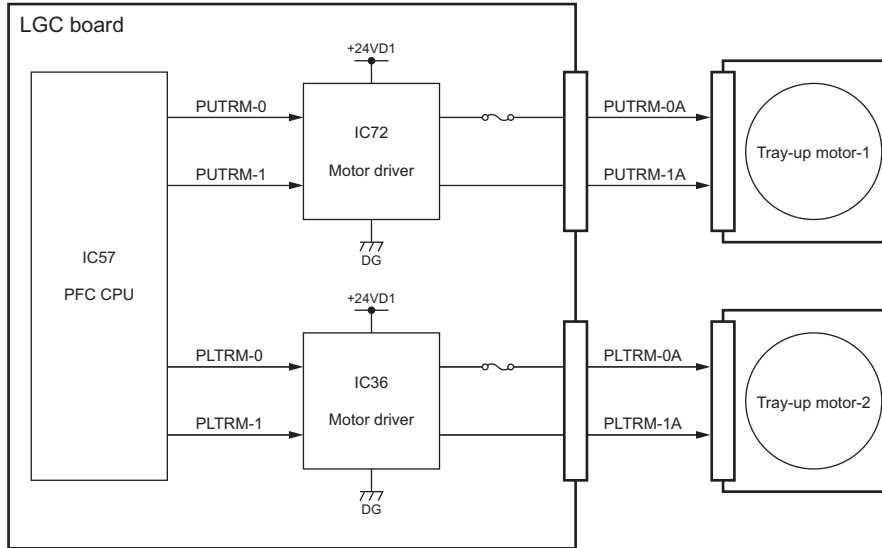

Fig. 8-7

Tray-up motor drive signal

Signal				Motor Status
PFC CPU output		Motor driver output		
PUTRM-0 PLTRM-0	PUTRM-1 PLTRM-1	PUTRM-0A PLTRM-0A	PUTRM-1A PLTRM-1A	
L	L	OFF (high impedance)		OFF
L	H	L	H	Forward rotation (CW)
H	L	H	L	Reverse rotation (CCW)
H	H	L	L	Brake

8.5 Feed motor control circuit

The feed motor is a DC motor driven by the control signal output from the PFC CPU and ASIC on the LGC board and rotates the pick-up roller, feed roller, separation roller and transport roller for each drawer, the tandem LCF and bypass unit.

When the ON/OFF signal (PFMON-0) output from the PFC CPU is L level, the feed motor is driven at a speed based on the frequency of the reference clock signal (PFMCK-1) output from the ASIC.

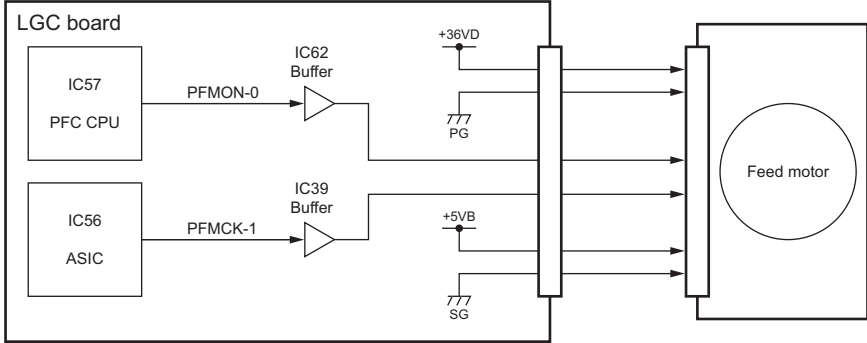

Fig. 8-8

8.6 Transport motor control circuit

The transport motor is a stepping motor driven by the control signal output from the PFC CPU on the LGC board and rotates the intermediate transport roller.

The transport motor is driven by the pulse signal (MTMA-0, MTMB-0, MTMAB-0, MTMBB-0) output from the motor driver. These pulse signals are formed based on the reference clock signal (MTMCK-0), and output only when the enable signal (MTMEN-0) is L level. Also, the rotational speed of the motor is switched by changing the frequency of the reference clock signal (MTMCK-0).

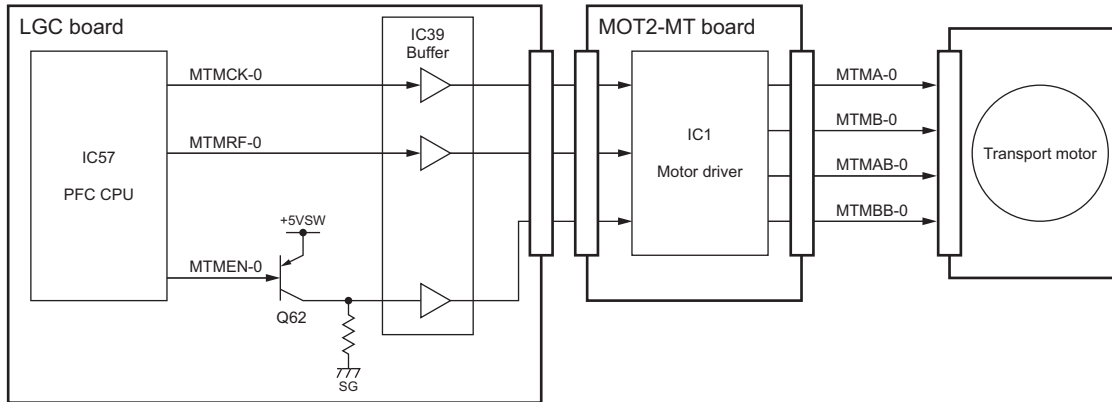

Fig. 8-9

Transport motor drive signal

Signal			Motor status
MTMCK-0	MTMEN-0	MTMRF-0	
Pulse signal	L	L	Rotation when accelerating/ decelerating
	L	H	Rotation at a constant speed
-	H	-	Stop

8.7 Registration motor control circuit

The registration motor is a stepping motor driven by the control signal output from the main CPU on the LGC board and rotates the registration roller.

The main CPU outputs each phase signal (RGTA-0, RGTB-0, RGTC-0, RGTD-0) to the motor driver. The motor driver converts this phase signal into a +24 V pulse signal (RGTA-0A, RGTB-0A, RGTC-0A, RGTD-0A) and outputs it to the motor. Also, the rotation speed of the motor can be switched by changing the output timing of each phase signal.

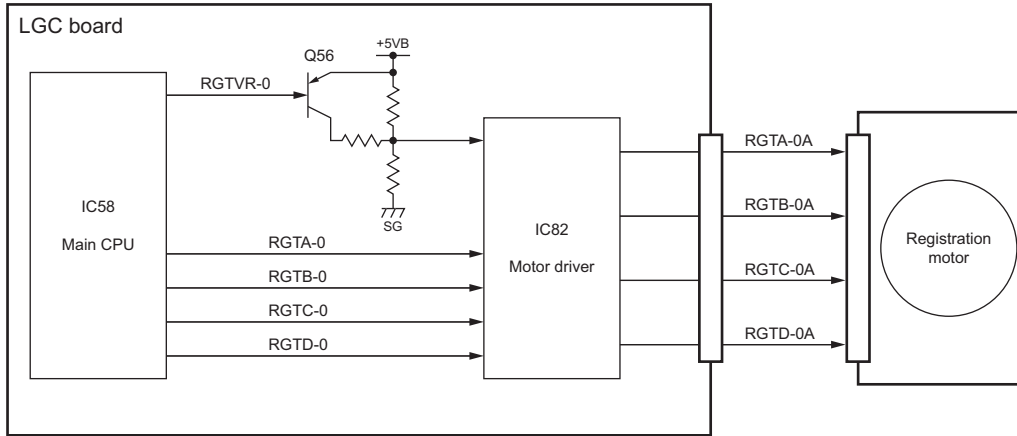

Fig. 8-10

Registration motor drive signal

Signal		Motor status
RGTA-0 RGTB-0 RGTC-0 RGTD-0	RGTVR-0	
Pulse signal	L	Rotation when accelerating/ decelerating
	H	Rotation at a constant speed

8.8 Tandem LCF tray-up motor / end fence motor

The tandem LCF tray-up motor and end fence motor, which are DC motors driven by the control signal output from the PFC CPU on the LGC board, move the tray up in the tandem LCF and shift the end fence.

The motor driver outputs the drive signal (TLTRM-0/1A, TLTMM-0/1A) to the motor based on the control signal (TLTRM-0/1, TLTMM-0/1) output from the PFC CPU. The motor operates the forward rotation, reverse rotation, brake or stop according to the status of these drive signals.

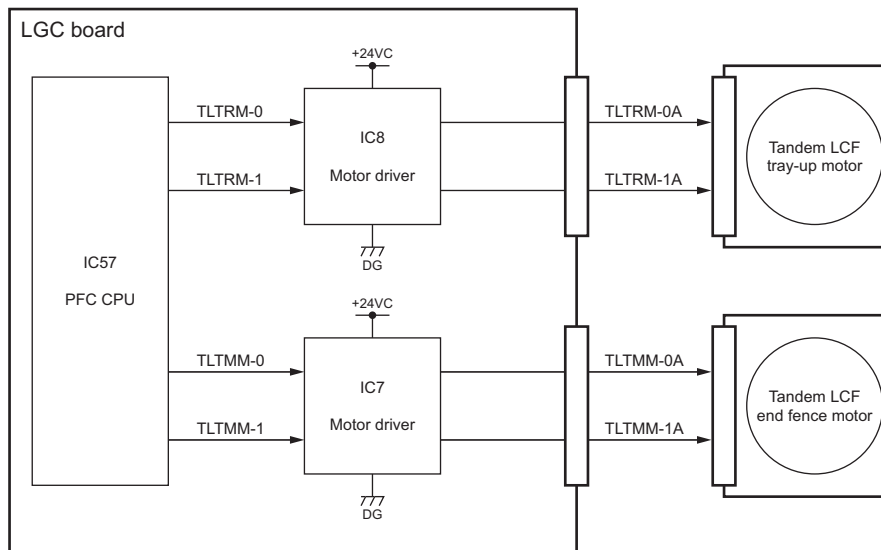



Fig. 8-11

Tray-up motor / end fence motor drive signal

Signal				Motor status
PFC CPU output		Motor driver output		
TLTRM-0 TLTMM-0	TLTRM-1 TLTMM-1	TLTRM-0A TLTMM-0A	TLTRM-1A TLTMM-1A	
L	L	OFF (high impedance)		OFF
L	H	L	H	Reverse rotation (CCW)
H	L	H	L	Forward rotation (CW)
H	H	L	L	Brake

8.9 Disassembly and Replacement

[A] Paper feeder unit / Bypass feed unit

- (1) Take off the right rear cover
( P.2-43 "[H] Right rear cover")
- (2) Open the right center cover to disconnect 1 connector.

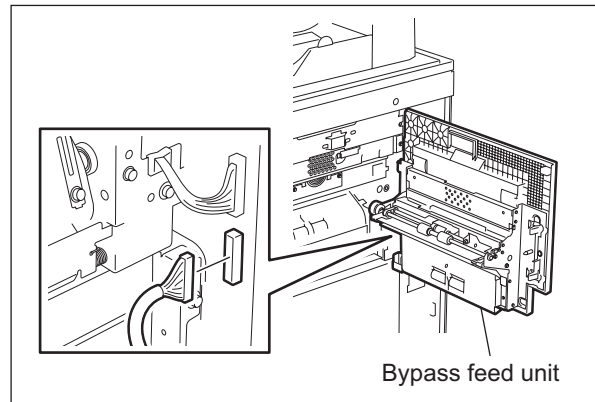

Fig. 8-12

- (3) Remove 2 pins and take off the bypass feed unit by lifting it and the feeder side center cover up.

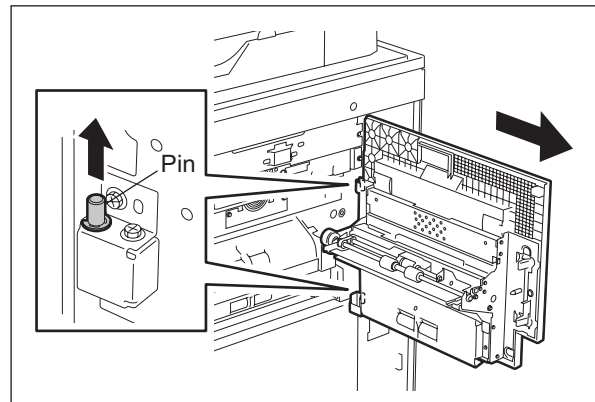

Fig. 8-13

- (4) Open the right lower cover and take it off by lifting it up.
- (5) Pull out the drawer completely.

Note:

If the drawer is not pulled out completely, when the paper feeder unit is taken off, the sensor may get damaged.

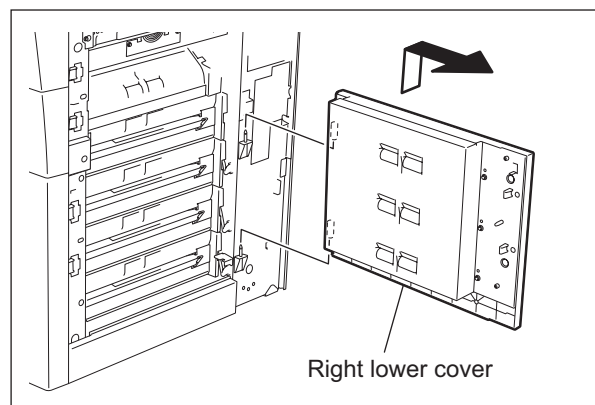

Fig. 8-14

- (6) Disconnect 1 connector and remove 3 screws to take off the paper feeder unit.

Note:

There are 4 identical paper feeder units (when the LCF is installed, there are 2).

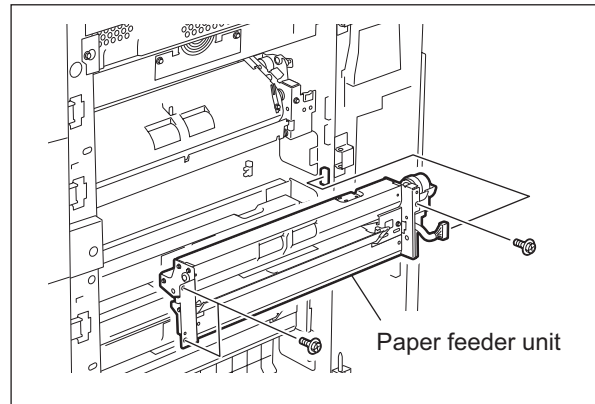

Fig. 8-15

[A-1] Pickup roller, Feed roller and Separation roller

- (1) Remove 1 clip to take off the pickup roller.

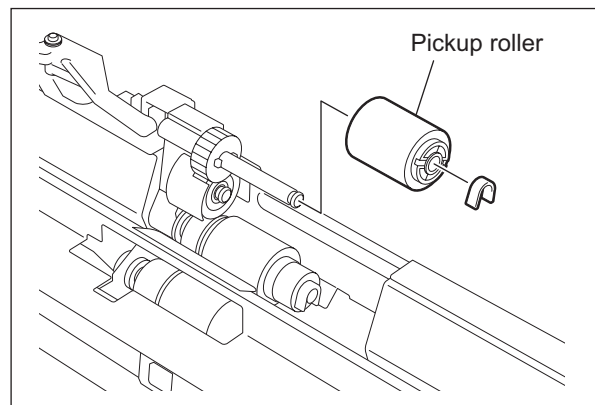

Fig. 8-16

- (2) Remove 2 screws to take off the guide.

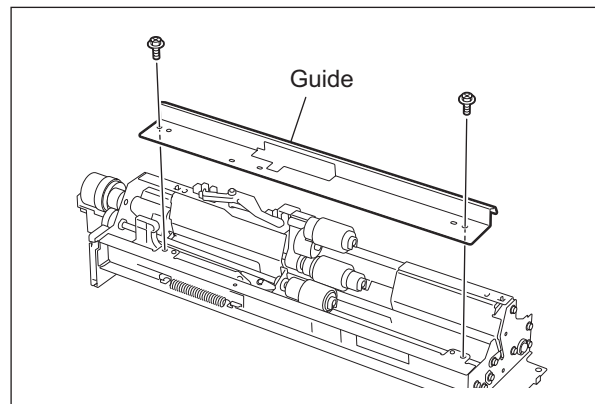

Fig. 8-17

- (3) Remove 1 clip to take off the feed roller.
- (4) Remove 1 clip to take off the separation roller.

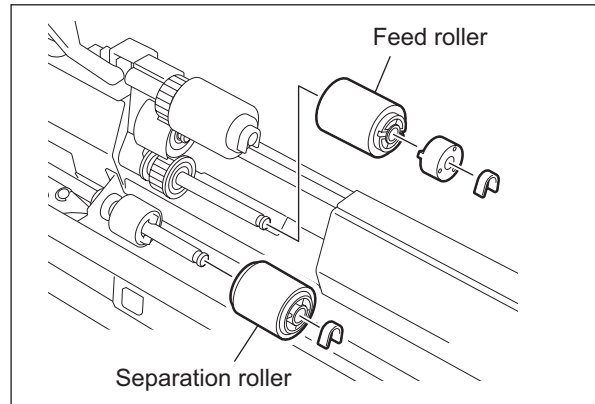

Fig. 8-18

[A-2] Drawer empty sensor (S31/S37/ S43/ S49)

- (1) Disconnect 1 connector to take off the drawer empty sensor.

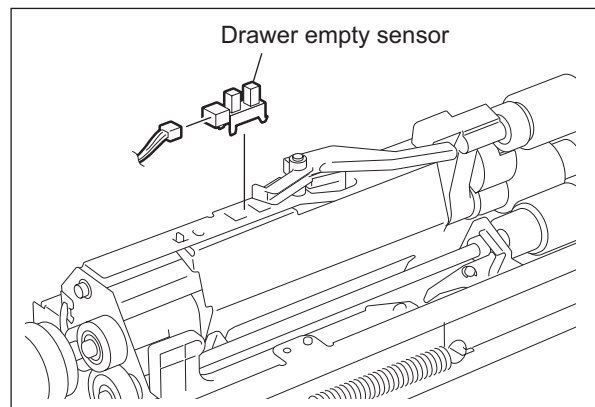

Fig. 8-19

[A-3] Tray-up sensor (S32/S38/S44/S50)

- (1) Disconnect 1 connector.
- (2) Pull the lever and take off the tray-up sensor while the pickup roller is lowered.

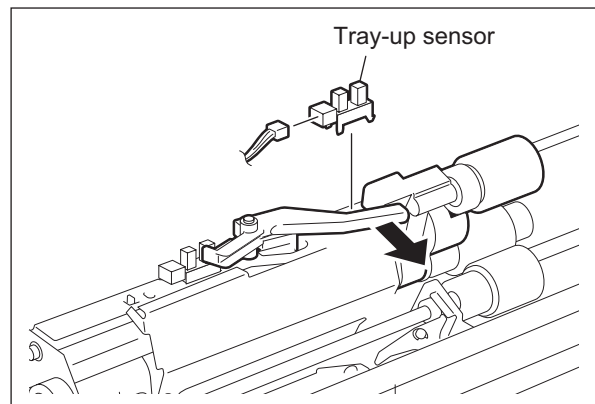

Fig. 8-20

[A-4] Transport sensor (S33/S39/S45/S51)

- (1) Remove 1 screw to take off the transport sensor with its bracket.
- (2) Disconnect 1 connector to take off the transport sensor.

Note:

When installing the sensor, make sure the sensor arm moves properly.

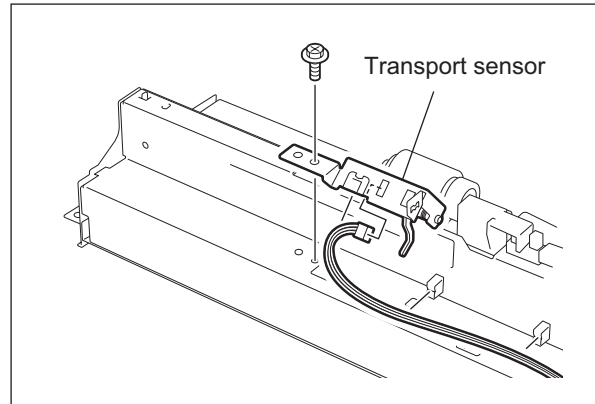

Fig. 8-21

[A-5] Feed clutch (CLT6/CLT8/CLT10/CLT12) and Transport clutch (CLT5/CLT7/CLT9/CLT11)

- (1) Release the harness from the harness clamp. Then remove 1 screw to take off the clutch cover.

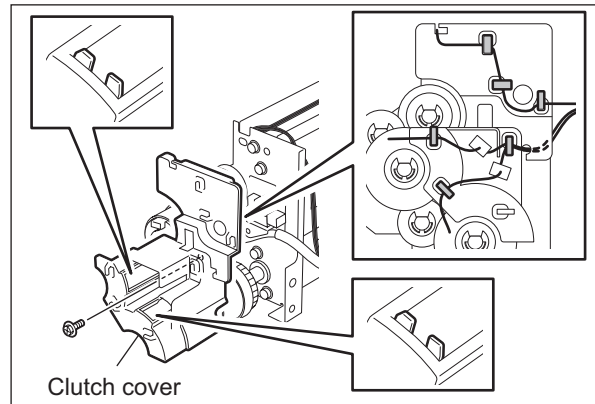

Fig. 8-22

- (2) Disconnect each connector and remove 1 E-ring to take off the feed clutch and transport clutch.

Notes:

1. When installing the clutch, do not insert the wrong harness.
2. Fit in the protrusion of the clutch to the stopper.
3. When fixing the clutch with the E-ring, be sure that the one side of the E-ring latch does not overlap the flat part of the shaft.

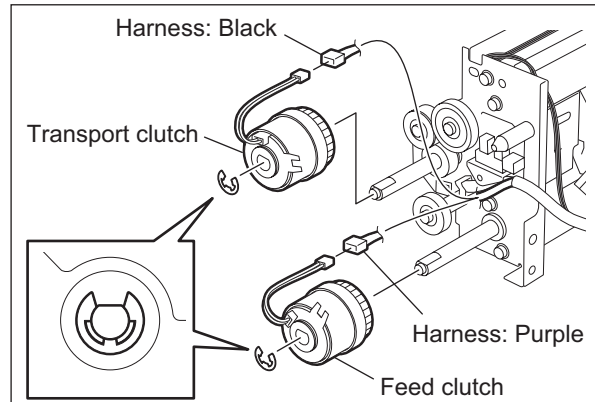

Fig. 8-23

[A-6] Drawer detection sensor (S29/S35/S41/S47)

- (1) Disconnect 1 connector to take off the drawer detection sensor.

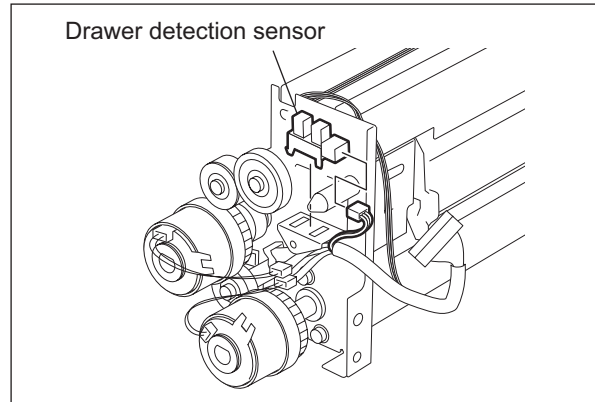

Fig. 8-24

[A-7] Drawer feed sensor (S34/S40/S46/S52)

- (1) Remove 1 screw to take off the drawer feed sensor with its bracket.
- (2) Disconnect 1 connector to take off the drawer feed sensor.

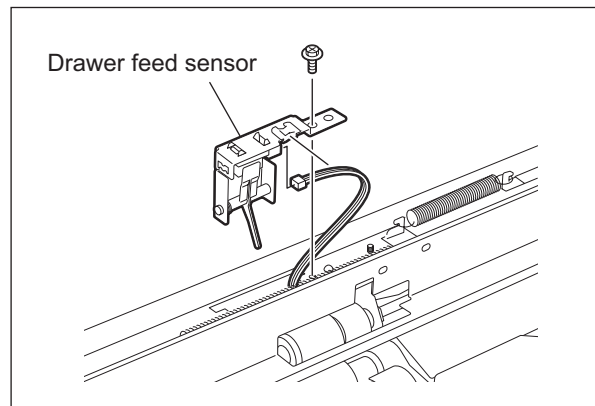



Fig. 8-25

[A-8] Drawer bottom sensor (S30, S37, S42, S48)

- (1) Take off all the feed units.
( P.8-17 "[A] Paper feeder unit / Bypass feed unit")
- (2) Disconnect the connector and take off each drawer bottom sensor.

Note:

Equipment with the LCF does not have the 3rd and 4th drawer bottom sensors.

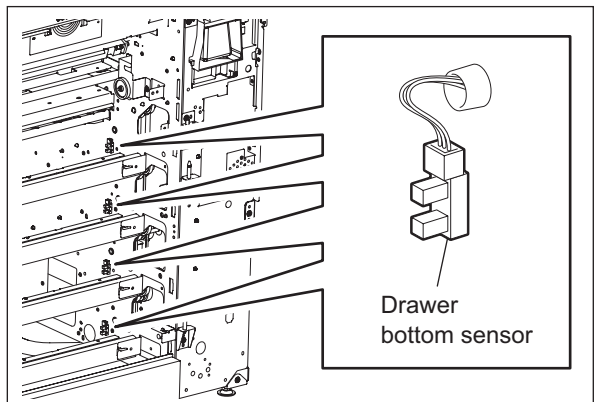

Fig. 8-26

[B] Intermediate transport unit

- (1) Take off the first paper feeder unit.
(P.8-17 "[A] Paper feeder unit / Bypass feed unit")
- (2) Disconnect 1 connector and remove 3 screws to take off the intermediate transport unit.

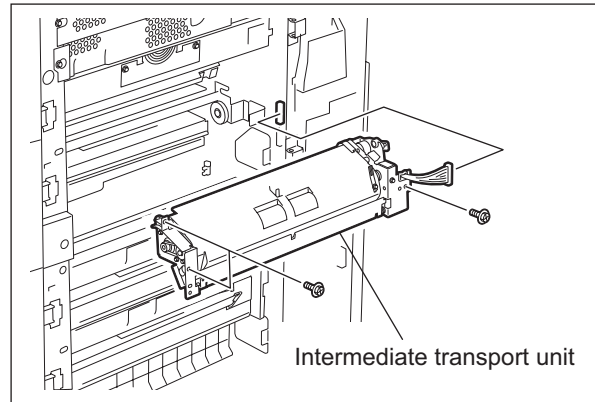

Fig. 8-27

[B-1] Motor driving PC board (MOT2-MT)

- (1) Release the harness from the harness clamp. Then remove 2 screws to take off the bracket.

Note:

Be careful not to drop the gear because it will come out of place when its bracket is taken off.

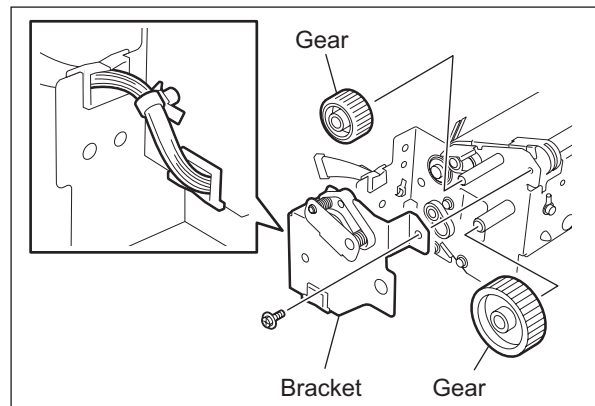

Fig. 8-28

- (2) Remove 1 screw on the varistor.
- (3) Removing 4 screws and 4 bushings to take off the paper guide.

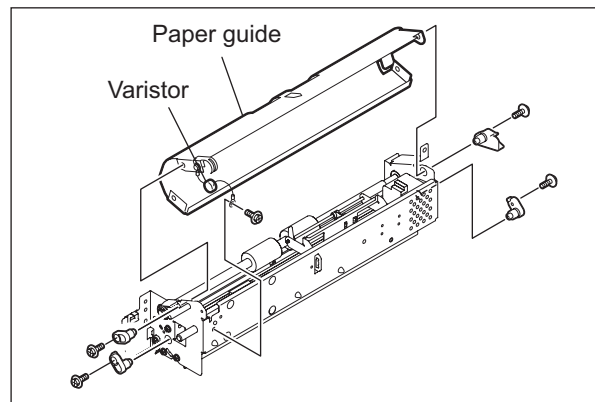

Fig. 8-29

- (4) Disconnect 2 board connectors and release 4 lock supports to take off the board.

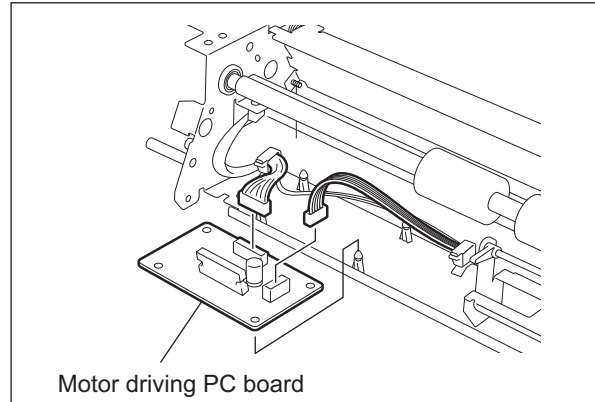

Fig. 8-30

[B-2] Transport motor (M17)

- (1) Disconnect 1 connector.
- (2) Remove 2 screws to take off the motor.

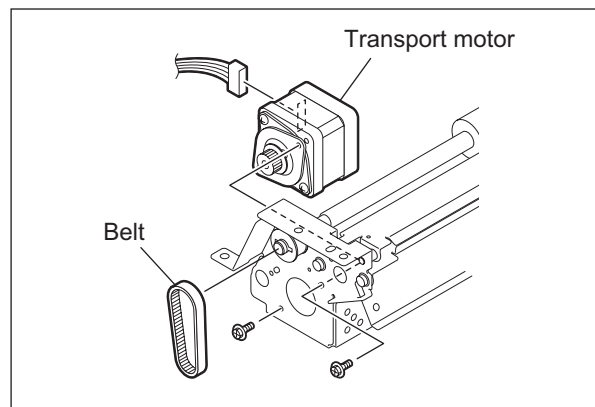

Fig. 8-31

[B-3] Transport roller

- (1) Remove 1 E-ring to pull out the bearing from the shaft.
- (2) Remove the pin of the pulley by moving the shaft toward the motor. Then remove the pulley and bearing to take off the transport roller with its shaft.

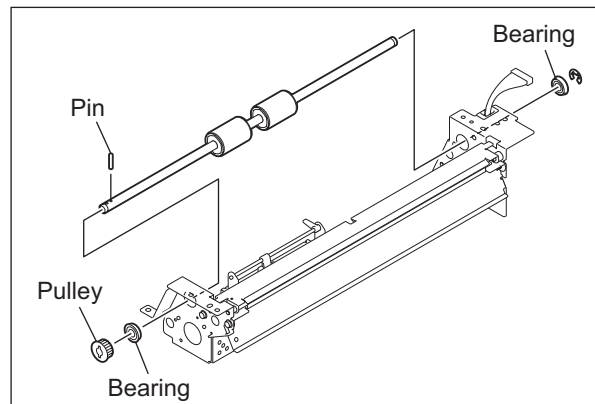

Fig. 8-32

- (3) Remove 2 E-rings to pull out the transport rollers from the shaft.

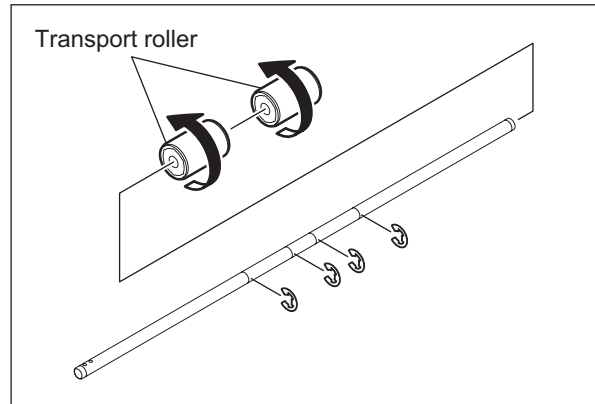

Fig. 8-33

[B-4] Intermediate transport sensor (S17)

- (1) Disconnect 1 connector.
- (2) Take off the sensor while the sensor arm is pushed downward (the shield plate is pushed upward).

Note:

When installing the sensor, make sure the sensor arm moves properly.

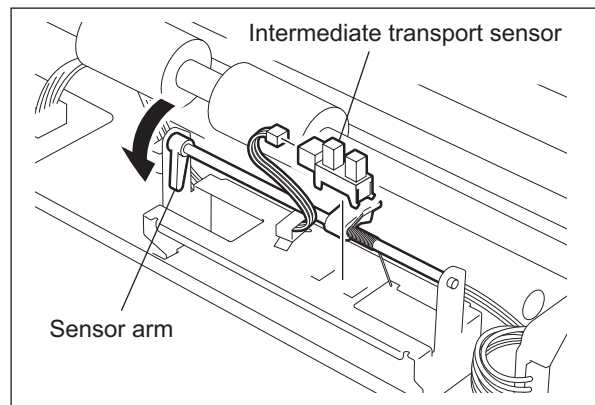

Fig. 8-34

[C] Bypass feed unit

- (1) Take off the bypass feed unit.
(P.8-17 "[A] Paper feeder unit / Bypass feed unit")

[C-1] Bypass feed roller / Pickup roller

- (1) Remove 1 clip and 1 bushing and displace the bypass transport roller.

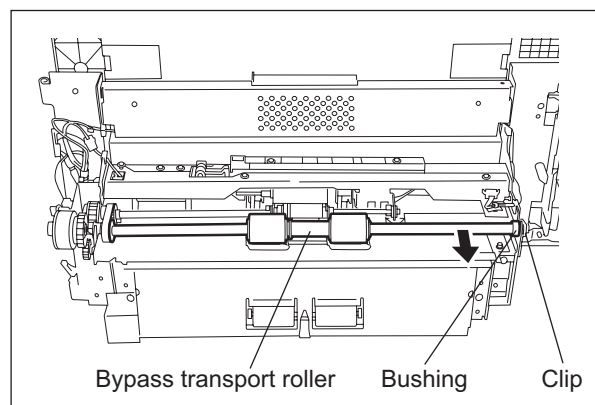

Fig. 8-35

- (2) Remove 2 clips and take off the bypass feed roller / pickup roller by sliding the bushing and pulley to the inside.

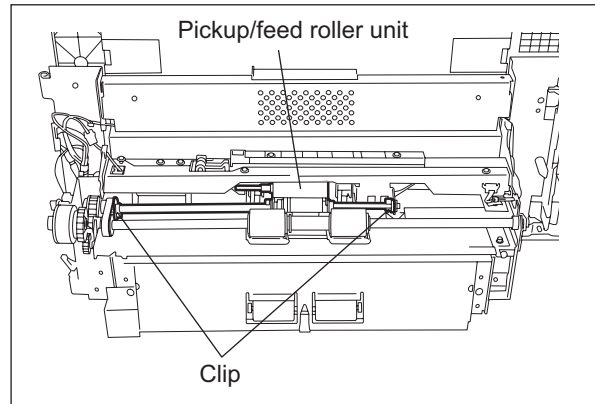

Fig. 8-36

- (3) Remove 2 clips and pull out the shaft to take off the pickup roller.
 (4) Remove 2 clips and pull out the shaft to take off the paper feed roller.

Notes:

1. When assembling the roller, do not install the wrong bushing.
2. Be sure to install the feed roller in the correct direction because it has a one-way clutch inside it.
3. Make sure there is no staining such as oil on the surface of the timing belt, pulley and roller.

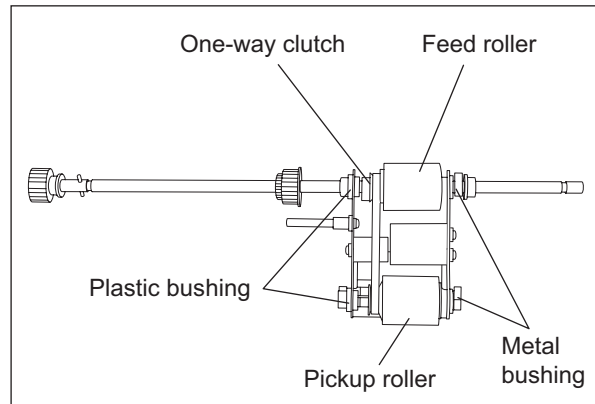

Fig. 8-37

[C-2] Bypass feed clutch (CLT4)

- (1) Disconnect the connector and then remove the harness band and clip to take off the bypass feed clutch.

Note:

When assembling, be sure that the stopper of the clutch is securely inserted into the groove of the bracket.

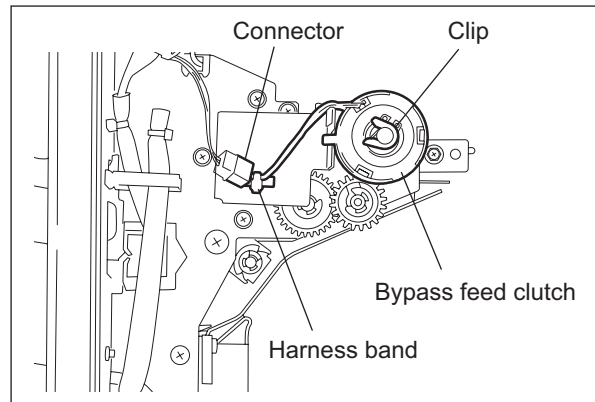

Fig. 8-38

[C-3] Bypass pickup solenoid (SOL3) / Bypass feed sensor (S27)

- (1) Remove 5 screws, disconnect 2 connectors and take off the stay.

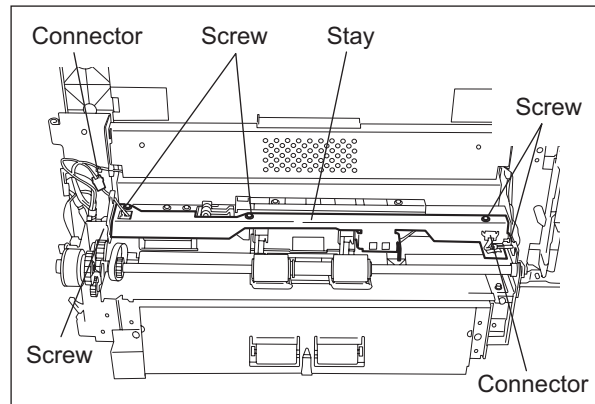

Fig. 8-39

- (2) Disconnect the connector and take off the bypass feed sensor.

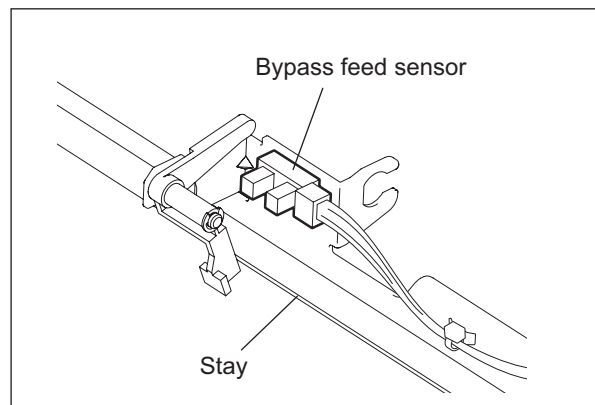

Fig. 8-40

(3) Remove 2 screws to take off the solenoid.

Notes:

1. When installing the solenoid, install it for the edge of the solenoid to get in phase with the edges of the plate.

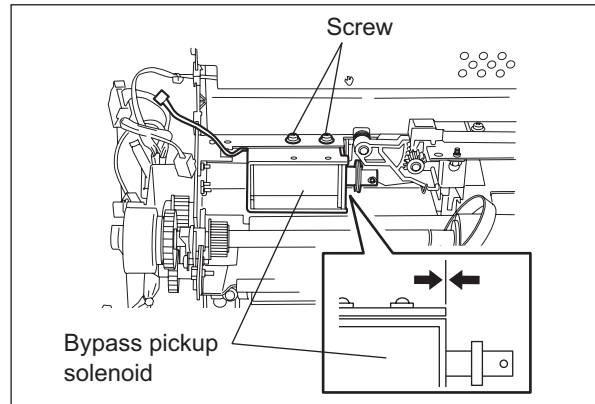

Fig. 8-41

2. When installing the solenoid, fix it at the position where the bosses of two gears are put each other.
3. Put on the spring in the place shown by the figure.

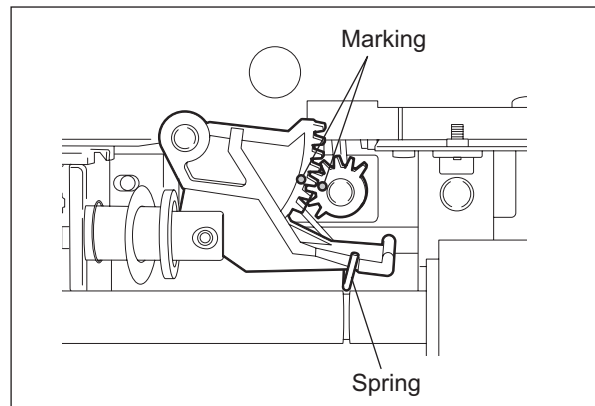

Fig. 8-42

[C-4] Separation roller

(1) Remove 4 screws to take off the paper guide.

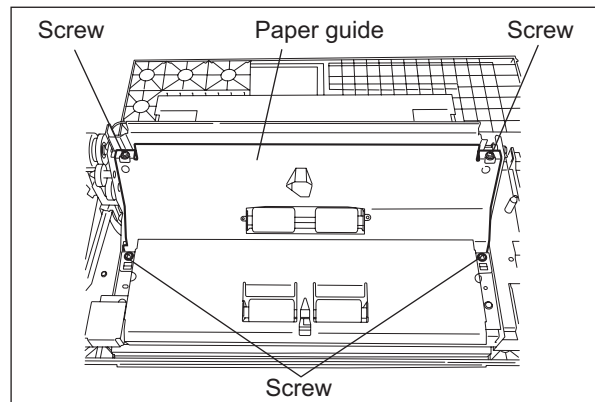

Fig. 8-43

- (2) Remove 1 clip and take off the separation roller by lifting the shaft.

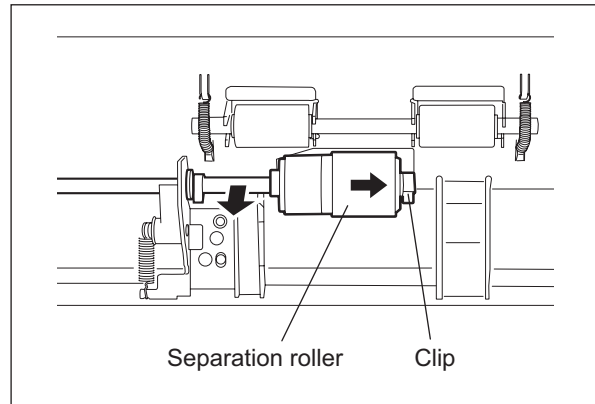

Fig. 8-44

[C-5] Bypass paper size detection sensor (S28)

- (1) Disconnect 1 connector and release it from the clamp.
- (2) Remove 2 brackets on both sides of the tray and 2 screws each to take off the bypass tray.

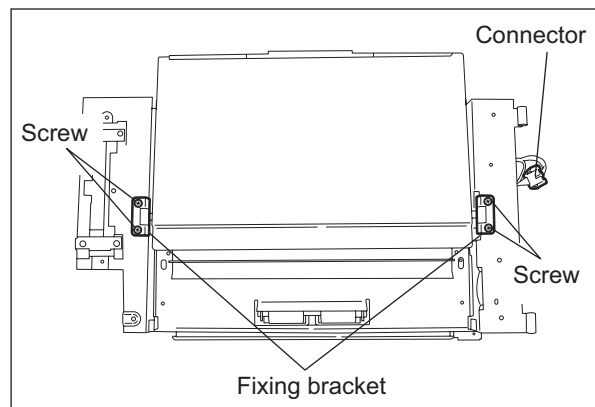

Fig. 8-45

- (3) Remove 3 screws and release 4 latches to take off the bypass tray upper cover.

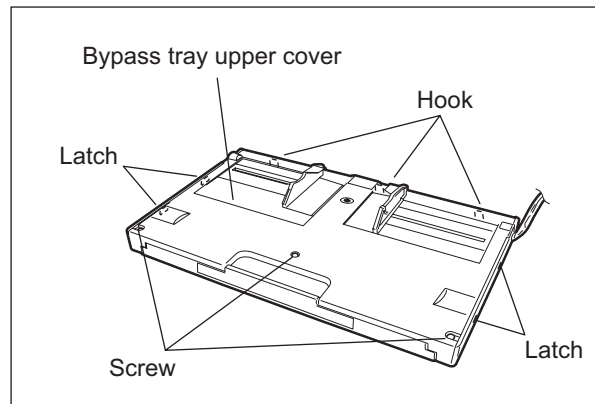

Fig. 8-46

- (4) Remove 1 screw and take off the ground leaf spring.
- (5) Remove 1 screw (white arrow) and take off the bracket.

Note:

Install the bracket with its indicator pointed to its original position.

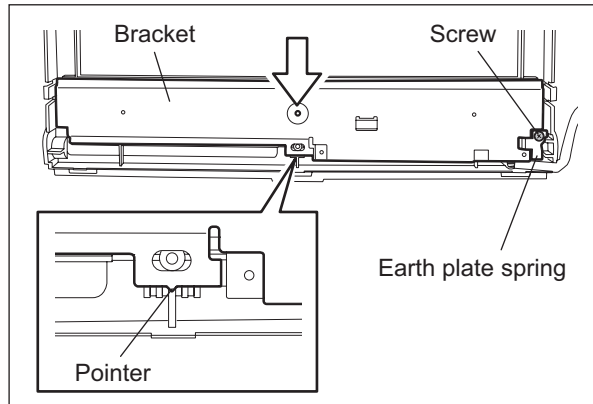

Fig. 8-47

- (6) Disconnect 1 connector and remove 1 screw to take off the bypass paper size detection sensor.

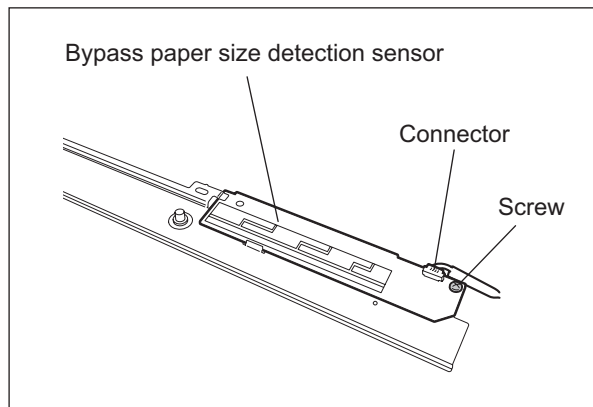

Fig. 8-48

Note:

Pay attention to the following things when setting up the bypass feed roller and pickup roller.

- Put the clip in the groove of the shaft completely.
- Make sure there is no adhesion of oil and such on the timing belt, pulley and roller.
- Be careful not to install the bypass pickup roller and feed roller in a wrong direction.
- Install the feed roller for the one-way clutch to come to the rear side.

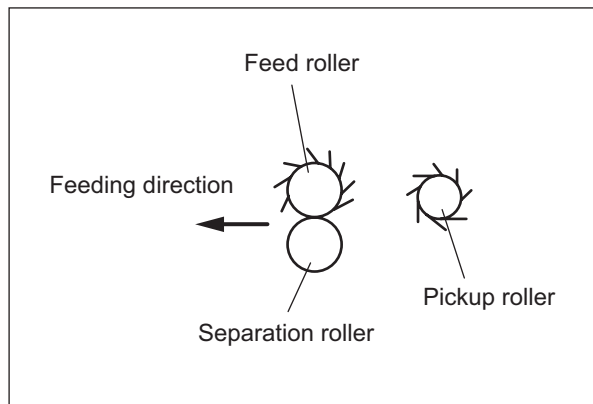

Fig. 8-49

[D] Feed motor (M20)

- (1) Take off the rear cover.
(☞ P.2-45 "[L] Rear cover")
- (2) Disconnect 1 connector, release 1 lock support and then remove 3 screws to take off the feed motor.

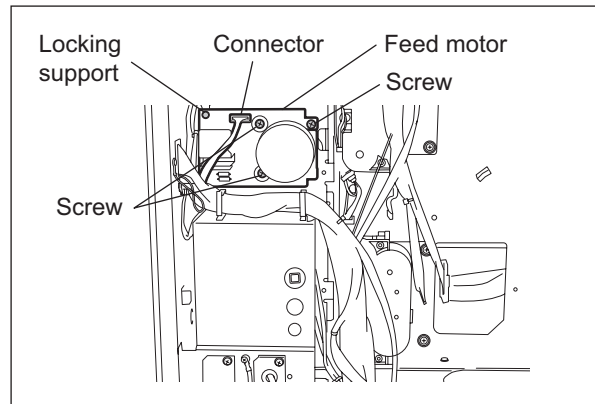

Fig. 8-50

[E] Tray driving unit (upper/lower) / Tray-up motor (M21, M22)

- (1) Take off the switching regulator.
(☞SERVICE HANDBOOK "[E] Switching regulator (PS)")
- (2) Remove 4 screws to take off the tray driving unit (upper).

Note:

Both the upper and lower sides have the same tray driving units.

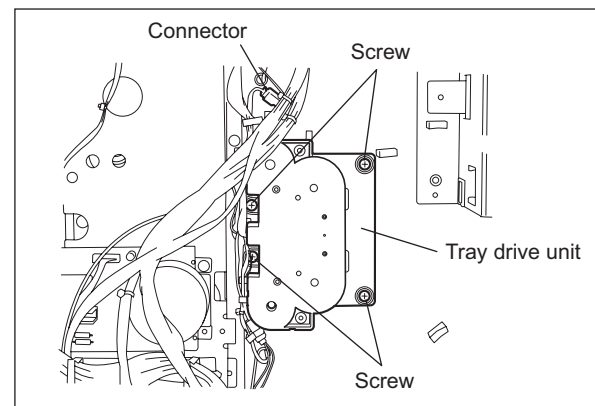

Fig. 8-51

- (3) Reverse the tray driving unit and release 6 latches to take off the cover.

Note:

The spring which pushes open the cover is inside the tray driving unit, so be careful when you remove the cover.

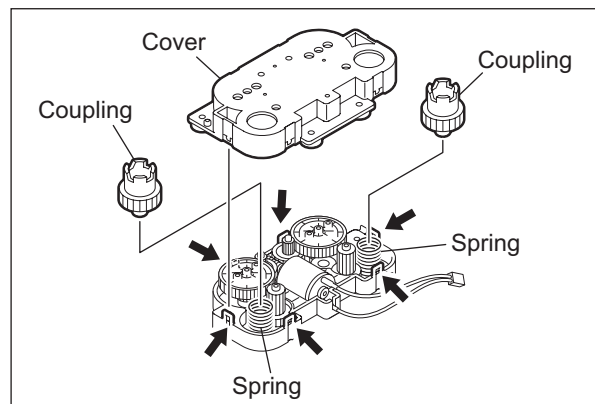

Fig. 8-52

- (4) Take off the tray-up motor.

Note:

Align the boss of the gear and the hole of the cover when installing the tray-up motor.

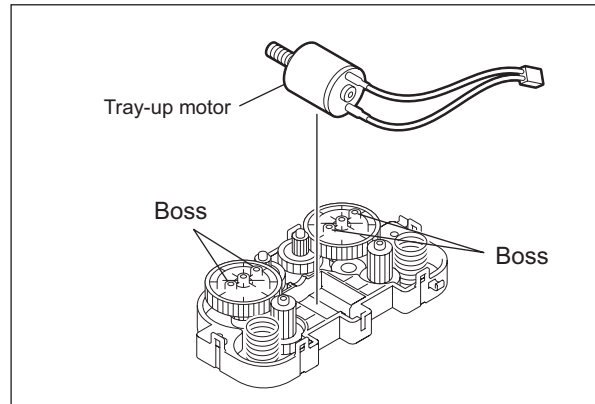

Fig. 8-53

[F] Feed driving unit

- (1) Take off the switching regulator.
(SERVICE HANDBOOK "[E] Switching regulator (PS)")
- (2) Take off the feed motor.
(P.8-30 "[D] Feed motor (M20)")
- (3) Disconnect 1 connector and remove 5 screws to take off the AC input.

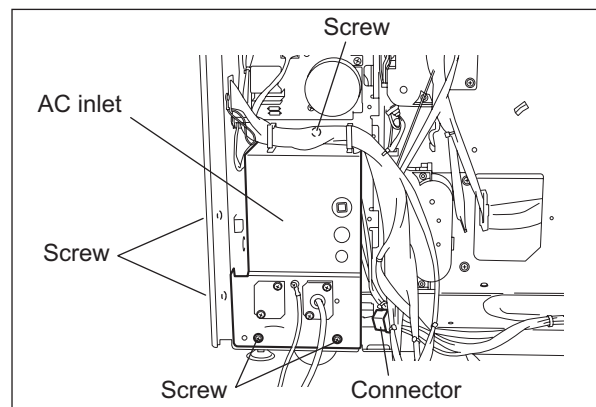

Fig. 8-54

- (4) Release the harness from the clamp and remove 6 screws to take off the feed driving unit.

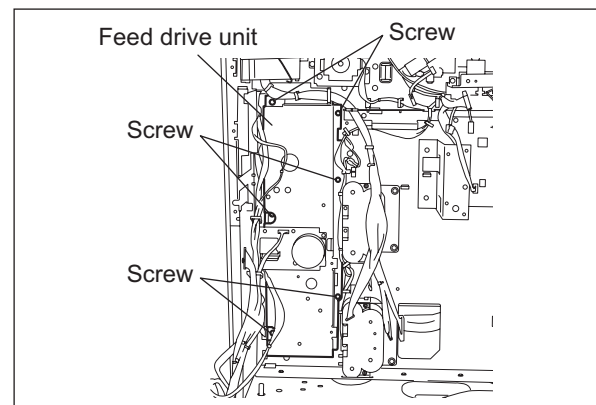

Fig. 8-55

[G] Registration roller unit

- (1) Take off the cleaner unit.
- (2) Remove 1 screw and take off the fixing bracket.
- (3) Open the right center cover and disconnect 1 connector.
- (4) Pull out the registration roller unit toward the front side while tilting it.

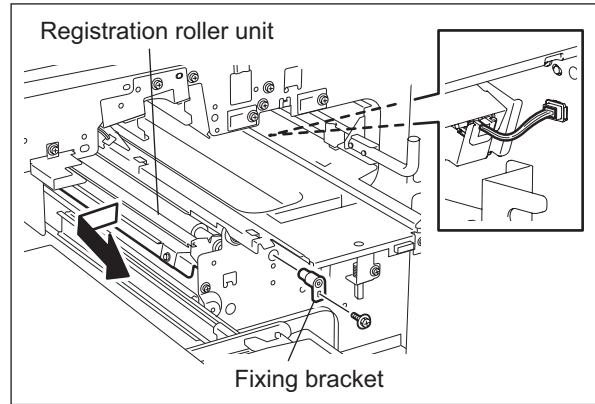

Fig. 8-56

[G-1] Registration roller (rubber)

- (1) Remove 2 screws and take off the paper guide.
- (2) Remove 1 screw and take off the plate spring.

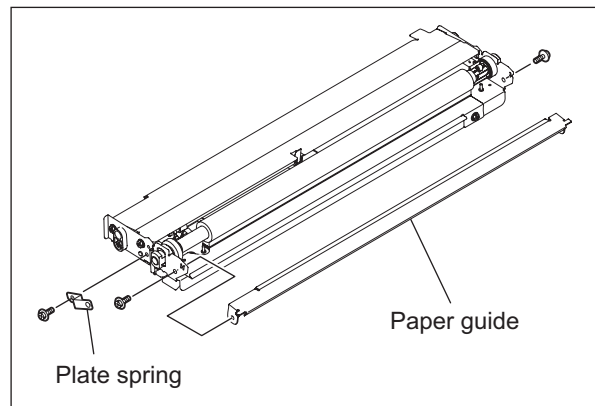

Fig. 8-57

- (3) Remove 1 clip and 2 springs.

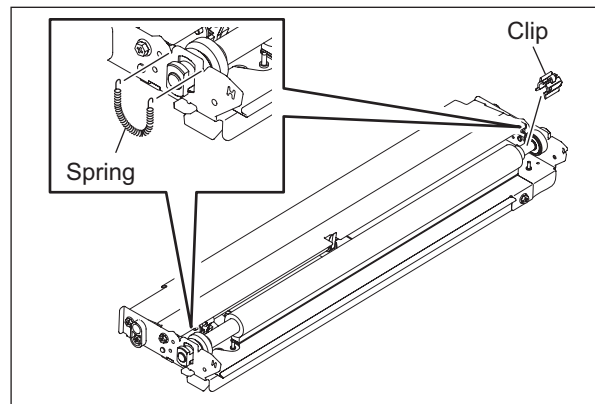

Fig. 8-58

- (4) Slide the registration roller to the front side, then take off the rear side to remove it.

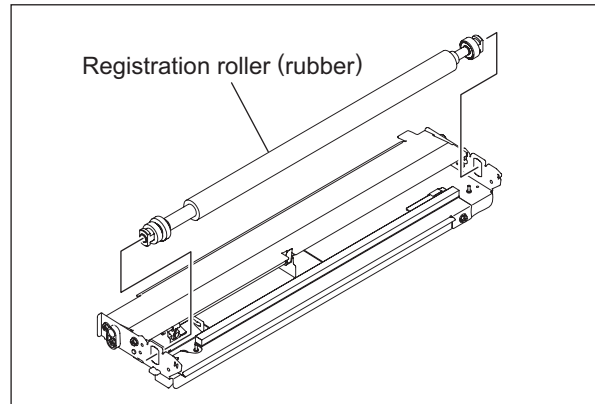

Fig. 8-59

- (5) Take off 2 bushings, gear and pin.

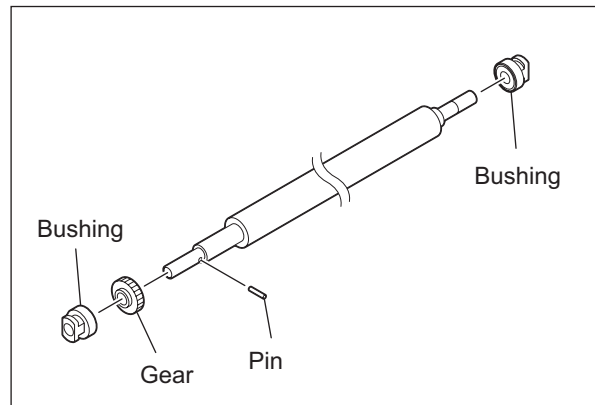

Fig. 8-60

[G-2] Registration sensor (S18)

- (1) Remove 1 screw and take off the sensor with the bracket.
(2) Disconnect 1 connector, release the latch and take off the sensor.

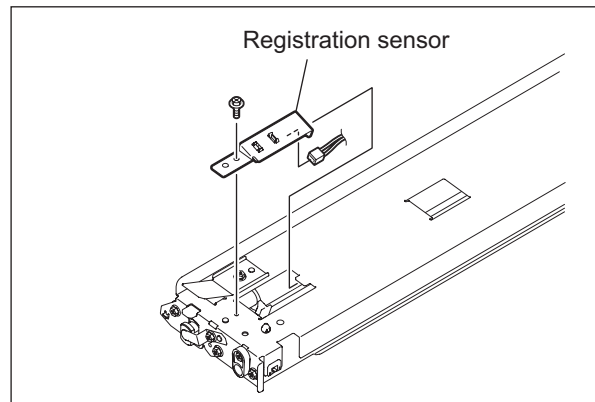

Fig. 8-61

[G-3] Paper dust removal brush 1 (for the rubber registration roller)

- (1) Remove 1 screw and take off the paper dust removal brush.

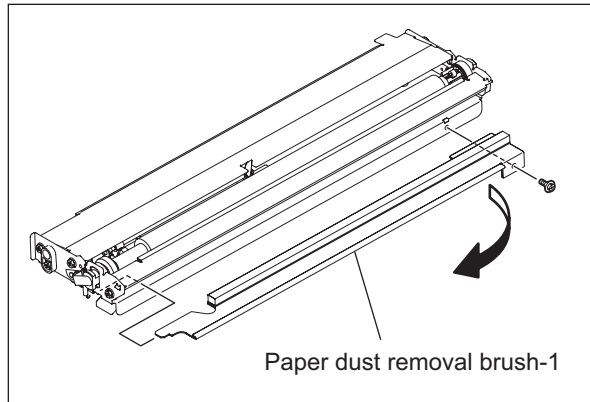

Fig. 8-62

[H] Paper dust removal brush 2 (for the metallic registration roller)

- (1) Take off the developer unit.
(P.11-16 "[C] Developer unit")
- (2) Remove 1 screw and take off the paper dust removal brush.

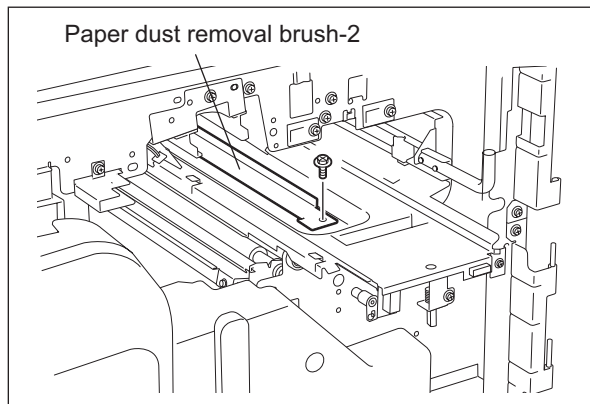

Fig. 8-63

[I] Registration motor (M16)

- (1) Take off the SYS board.
(P.2-45 "[L] Rear cover")
- (2) Remove 3 screws and take off the flywheel.
- (3) Remove 3 screws and take off the motor with the bracket.
- (4) Remove 2 screws and take off the motor.

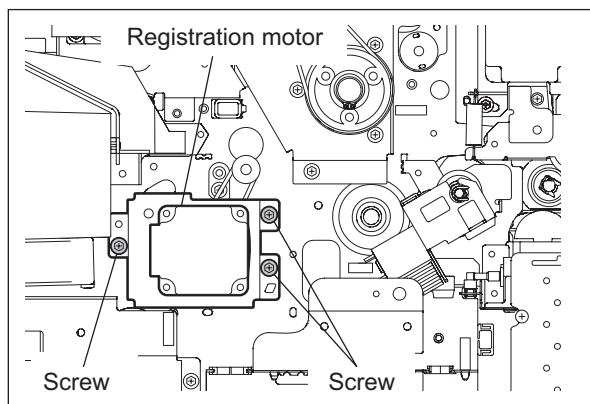

Fig. 8-64

[J] Tandem LCF

- (1) Pull out the tandem LCF
- (2) Remove 4 screws and take off the tandem LCF.

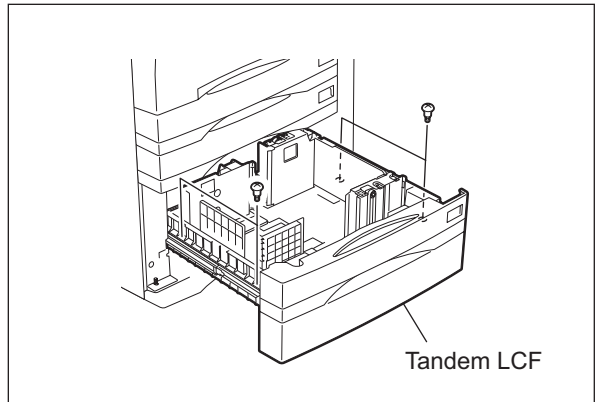

Fig. 8-65

[J-1] Standby side mis-stacking sensor (S72)

- (1) Remove 1 screw and take off the bracket.
- (2) Disconnect 1 connector, release the latch and take off the Standby side mis-stacking sensor.

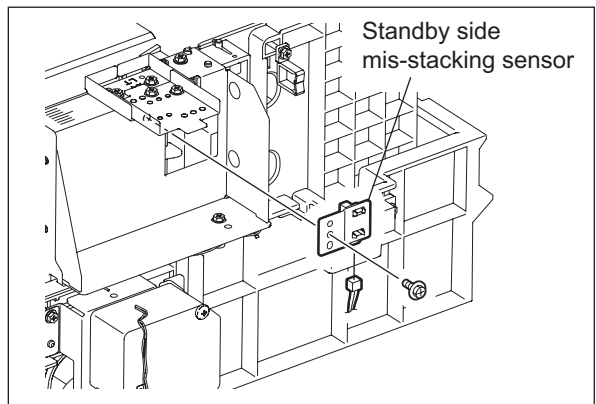

Fig. 8-66

[J-2] Tandem LCF end fence motor (M42)

- (1) Remove 1 E-ring and take off 1 bushing.
- (2) Disconnect 1 connector, remove 3 screws and take off the motor with the bracket.

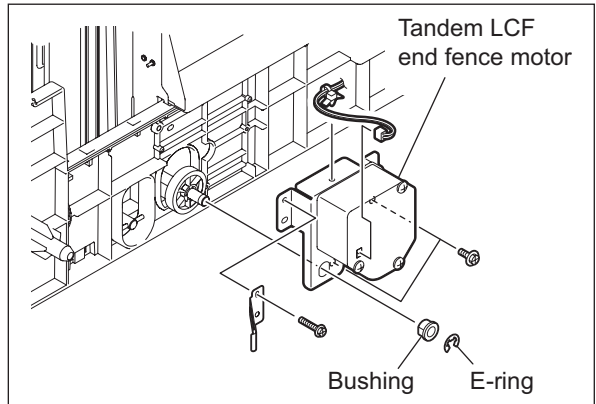

Fig. 8-67

Note:

When assembling, wire the harness and fix it with filament tape as shown in the figure. (Be sure not to wire it on the side of the motor.)

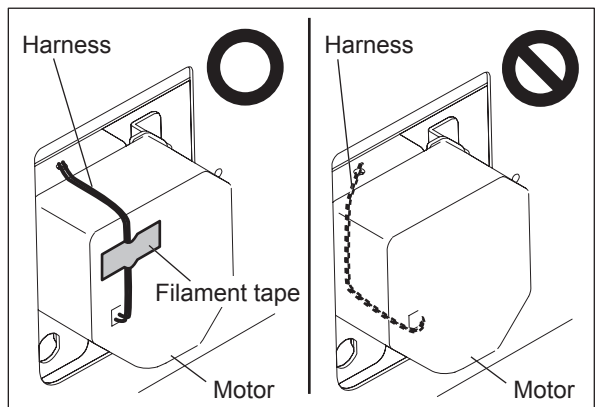

Fig. 8-68

- (3) Release 2 gear latches and remove the gear.

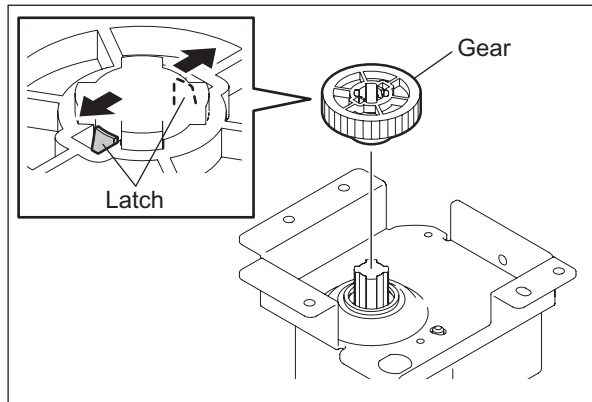

Fig. 8-69

- (4) Remove 3 screws and take off the tandem LCF end fence motor.

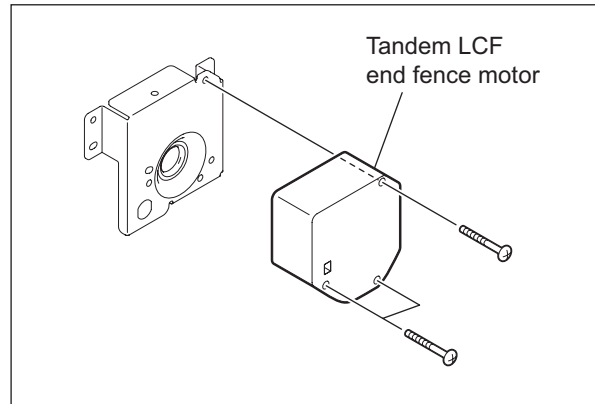

Fig. 8-70

[J-3] Tandem LCF end fence solenoid (SOL8)

- (1) Remove 4 screws and take off the bracket.
- (2) Remove 1 screw and take off the tray-up unit side wall.
- (3) Remove 2 screws, disconnect 1 connector, and take off the tandem LCF end fence solenoid.

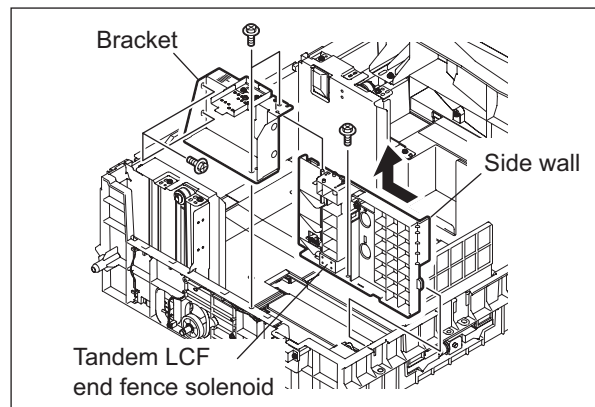

Fig. 8-71

[J-4] Tandem LCF bottom sensor (S71)

- (1) Remove 2 screws and take off the plates.

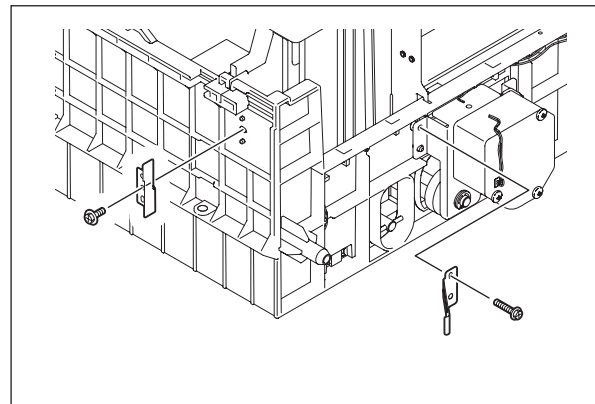

Fig. 8-72

- (2) Remove 2 screws and take off the tray-up unit.

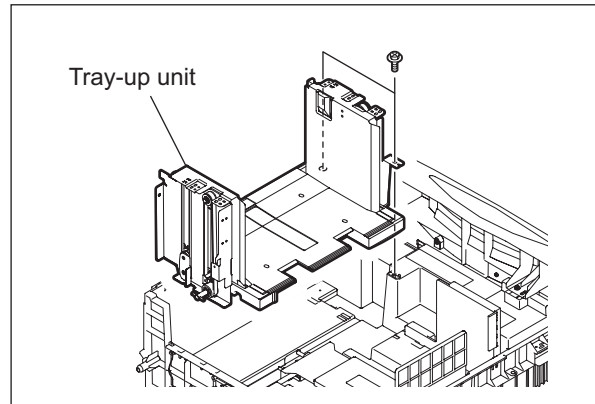

Fig. 8-73

- (3) Disconnect 1 connector, release the latch and take off the tandem LCF bottom sensor.

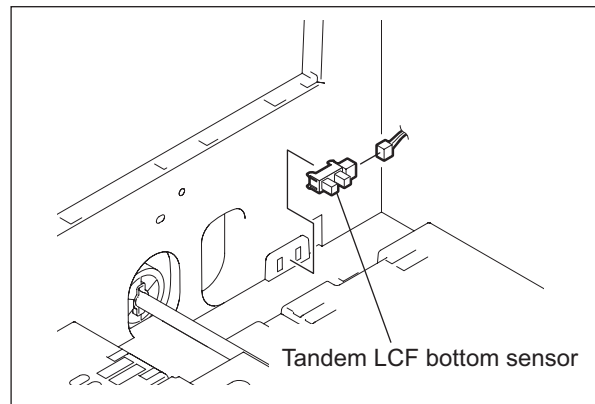

Fig. 8-74

[J-5] End fence home position sensor (S73) / Standby side empty sensor (S74) / End fence stop position sensor (S75)

- (1) Remove 1 screw and take off the plate cover.

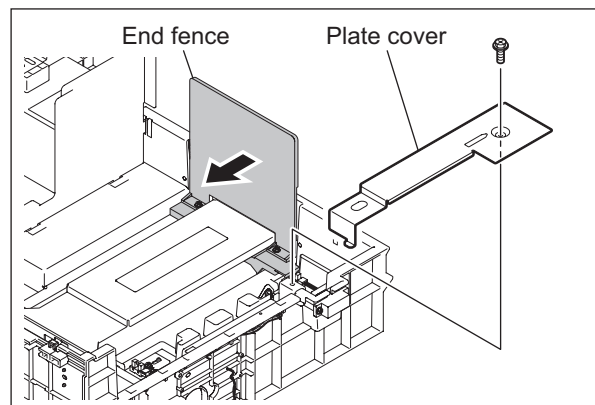

Fig. 8-75

- (2) Disconnect the connector for each sensor, and take off the sensor.

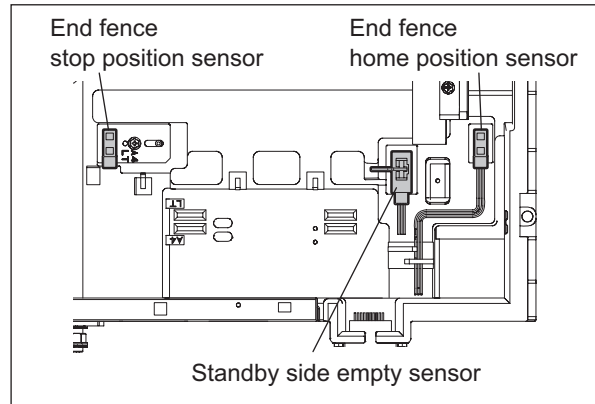

Fig. 8-76

[J-6] Tandem LCF tray-up motor (M41)

- (1) Take off the switching regulator.
(SERVICE HANDBOOK "[E] Switching regulator (PS)")
- (2) Disconnect 1 connector, remove 3 screws and take off the Tandem LCF tray-up motor.

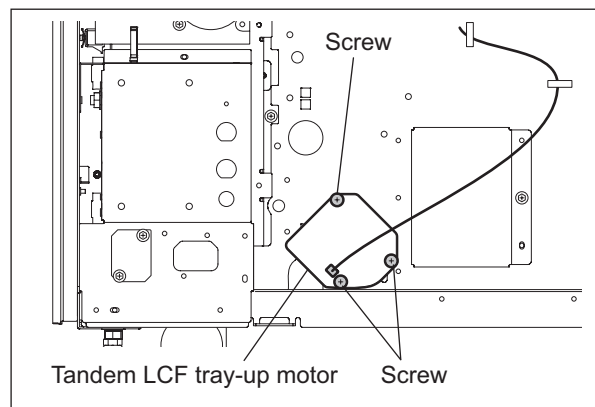

Fig. 8-77

9. PROCESS RELATED SECTION

9.1 Construction

This chapter describes the following unit regarding the image forming process.

- Main charger
- Charger wire cleaner
- Discharge LED
- Ozone filter
- Surface potential sensor
- High-voltage transformer
- Temperature/Humidity sensor

The drum/cleaner unit is described in chapter 10, the developer unit is described in chapter 11 and the transfer/transport unit is described in chapter 12.

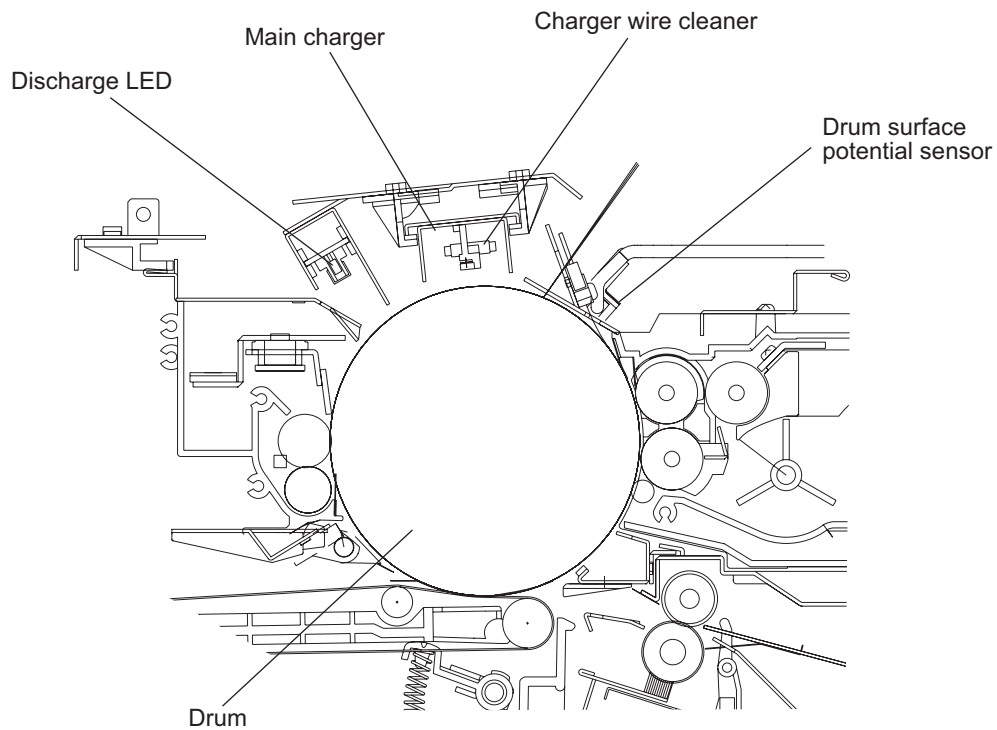

Fig. 9-1

9.2 Functions

- (1) Main charger
The main charger is configured by stretching a charger wire between two insulation blocks provided at both ends of the U-shaped metal rod.
When a high voltage is applied to the charger wire, the air around the wire is ionized (electrostatically charged), and this ionized air is attracted onto the drum's surface. This phenomenon is referred to as the "corona discharge". In the dark, the surface of the drum is negatively (-) charged by the corona discharge of the main charger.
- (2) Charger wire cleaner
It removes stains on the charger wire regularly to avoid poor charging and drum irregularities. The charger wire cleaner pad is pushed against the charger wire and moved to and fro on the wire to clean it. The charger wire cleaner drive motor (M12) moves the charger wire cleaner to and fro.
It cleans the wire when the power is turned ON, the cover interlock switch (SW8) is turned ON or 2000 or more continuous copies have been made since the previous cleaning.
- (3) Discharge LED (ERS)
Discharging is a process of reducing or eliminating the electrostatic charges on the drum. The discharge LED have two effects: a cleaning effect and a pre-exposure one. The cleaning effect neutralizes and eliminates the residual charges on the drum surface by lowering the electrical resistance of the photosensitive surface as a result of exposing it to the light, and the pre-exposure effect keeps a fixed drum surface potential before the charging process. There is an array of 14 LEDs with a 660 nm wavelength.
- (4) Ozone filter
Ozone produced by corona discharge of the main charger is exhausted through this filter. The catalyzer of the ozone filter degrades the ozone.
- (5) Drum surface potential sensor (S13)
It detects the surface potential of the photoconductive drum and performs control to keep the difference between the surface potential and the development bias constant.
- (6) High-voltage transformer
This board creates the output control voltage of the main charger, charge grid, power supply roller and developer bias.
- (7) Temperature/Humidity sensor (S7)
This sensor (S7) and drum thermistor (THM5) detect the temperature and humidity inside of the equipment since the drum, developer material and paper are affected by environmental elements such as temperature or humidity. Thus the main charger grid, transfer belt, developer bias, laser output and auto-toner output are controlled to be at their optimum states.
The temperature/humidity sensor (S7) is installed in the control panel.

9.3 Charger Wire Cleaner Control Circuit

9.3.1 General description

The charger wire cleaner control circuit drives the main charger wire cleaner in a periodical reciprocating movement to clean the main charger wire, on purpose of eliminating defective or irregular charging over the drum.

9.3.2 Configuration

The configuration of this control circuit is shown below.

- Wire cleaner drive motor:
Drives the wire cleaner in a reciprocating movement.
- Wire cleaner position detection switch:
Detects that the wire cleaner has reached to its home position (front side) or its stop position (rear side).
- Control section (LGC board):
Outputs the drive signal to the wire cleaner drive motor and detects the input signal from the wire cleaner position detection switch

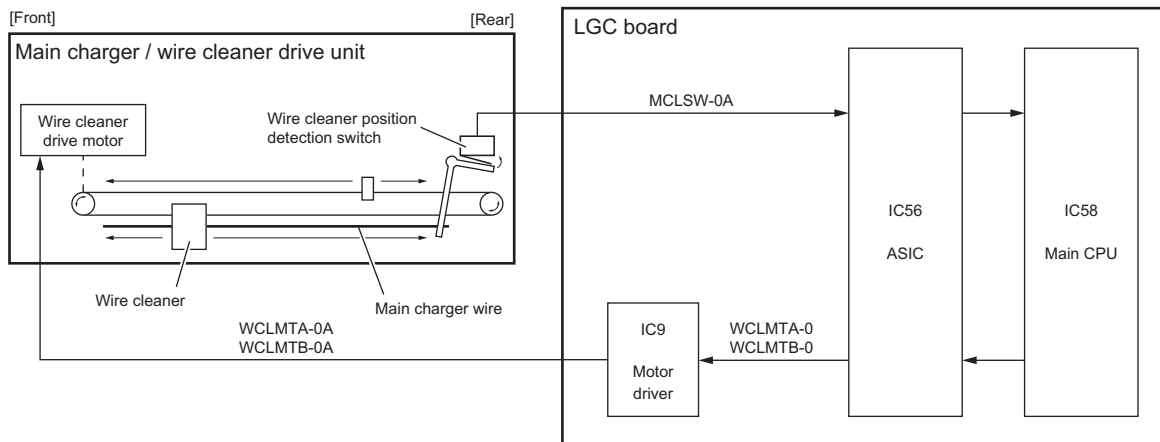

Fig. 9-2

Drive signal of wire cleaner drive motor

(L = Low level, H = High level)

Signal		Motor Status
WCLMTA-0A	WCLMTB-0A	
L	L	Off
H	L	Forward rotation (Stop position > Home position)
L	H	Reverse rotation (Home position > Stop position)
H	H	Brake

Signal	Low level	High level
MCLSW-0A	Cleaner detected (Cleaner reached to its home position or its stop position)	Cleaner not detected (During cleaning)

9.4 High-voltage Transformer Control Circuit

9.4.1 General description

The high-voltage transformer is controlled by the on-off signal of each bias output from the ASIC on the LGC board, and the reference voltage (Vctr) output through a D/A converter. The high-voltage transformer generates the output current or the output voltage of each bias, based on the input +24V voltage (+24VD1).

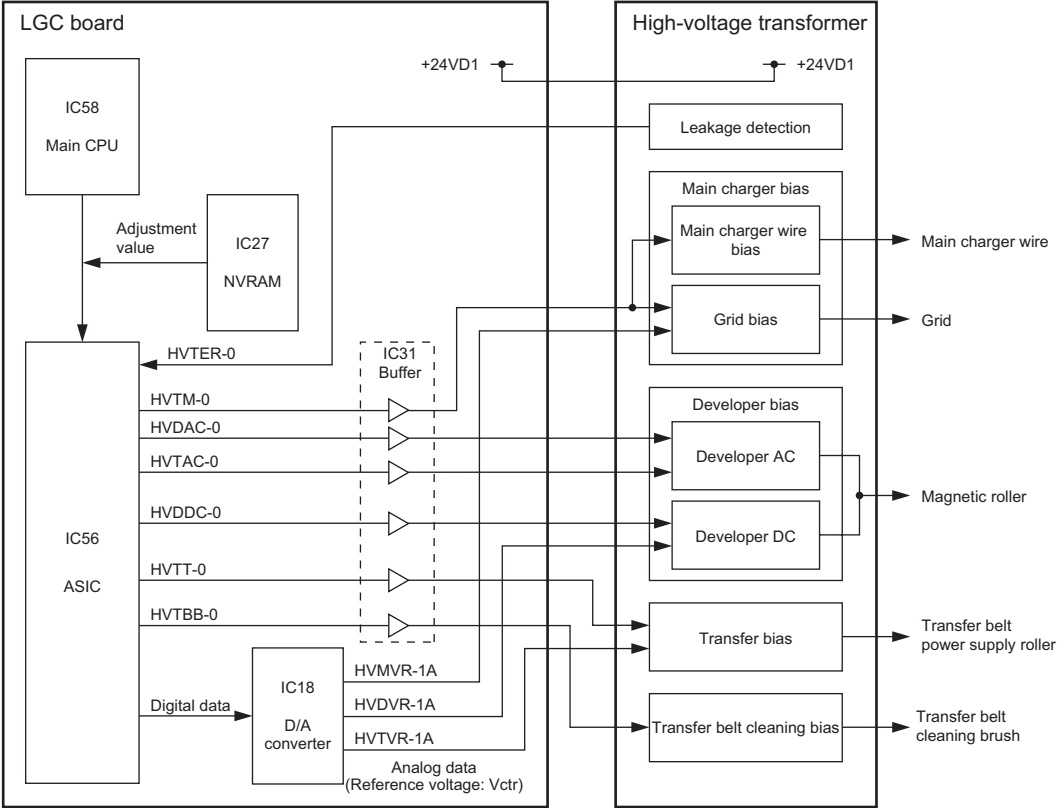

Fig. 9-3

9.4.2 Description of operation

The function and operation of each signal are as follows.

On-off signal (HVTM-0A, HVDAC-0A, HVDDC-0A, HVTT-0A, HVTBB-0A):

These signals are the on-off signals of each bias output to the main charger (main charger wire and grid), developer bias (AC/DC), transfer belt power supply roller, and transfer belt cleaning brush. When these signals move to a low level, the generating circuit of each bias on the high-voltage transformer becomes on status, thus the current or voltage is output.

Reference voltage (Vctr) (HVMVR-1A, HVDVR-1A, HVTVR-1A):

These analog voltages are the reference for each output of the main charger grid, developer bias (DC) and transfer belt power supply roller. Each output of the high-voltage transformer can be changed linearly by changing these reference voltages.

The output procedure of the reference voltages is shown below.

- The adjusted values of the main charger bias, developer bias and transfer bias in the NVRAM are output to the ASIC.
↓
 - The data of the reference voltage is output from the ASIC to the D/A converter.
↓
 - Digital-to-analog conversion at the D/A converter
↓
 - The reference voltage (Vctr) of each bias is output to the high-voltage transformer.
↓
 - The high-voltage transformer generates the output current or output voltage proportionate to the reference voltage.
- * The reference voltage (Vctr) can be adjusted in the Adjustment Mode (05).
* The output of the transfer belt cleaning brush was adjusted at a constant value when the high-voltage transformer was shipped from the factory, and this adjusted value has been fixed since then.

Developer AC bias generating clock (HVTAC-0A):

This clock signal is a reference for the AC component of the developer bias.

Leak detection signal (HVTER-0):

This signal detects the abnormality (leakage) of the high-voltage transformer output. When the abnormality is detected, the signal moves to a low level.

9.5 Drum Surface Potential Sensor Control Circuit

9.5.1 General description

The drum surface potential sensor measures the surface potential of the drum when the drum is charged. Based on the measured value, this sensor controls the main charger grid bias voltage, and thus can control the drum surface potential accurately.

9.5.2 Configuration

The configuration of this control circuit is shown below.

- Drum surface potential sensor:
Measures the drum surface potential.
- Control section (LGC board):
Calculates the main charger grid bias voltage to be applied when the image quality control is performed, then controls the high-voltage transformer to adjust its bias voltage output.
- High-voltage transformer:
Generates and supplies the bias voltage of the main charger grid.

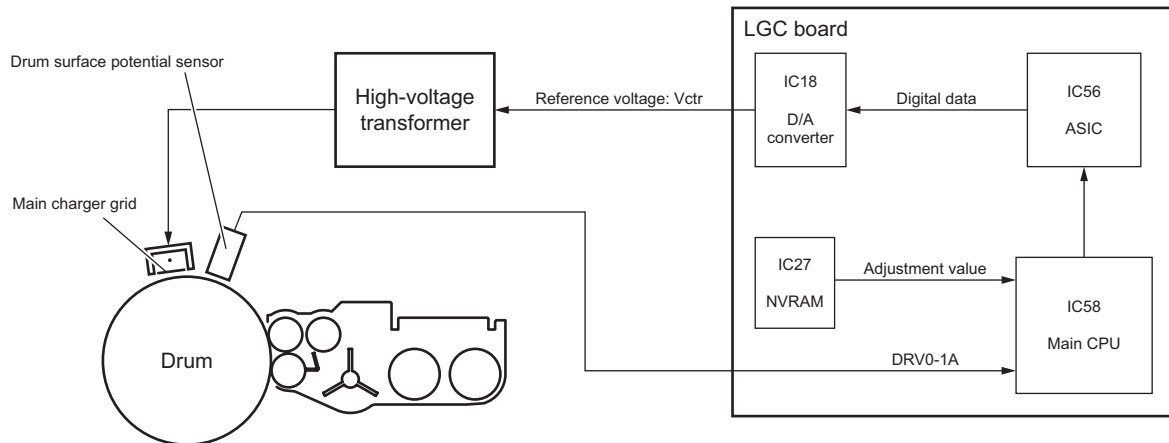

Fig. 9-4

9.5.3 Description of operation

1. Correction control procedure of drum surface potential

- The setting value of the main charger bias voltage when the surface potential stored in the NVRAM is measured is output to the Main-CPU.
↓
- The reference voltage data (digital data) is output from the Main-CPU to the D/A converter through the ASIC.
↓
- The reference voltage data is converted at the D/A converter into the reference voltage (V_{ctr}) (analog data), and the data is then output to the high-voltage transformer.
↓
- The high-voltage transformer outputs the main charger bias voltage based on the reference voltage, and thus the drum is charged.
↓
- The drum surface potential is measured by the drum surface potential sensor, and the measured value (DRV0-1A) is then fed back to the Main-CPU.
↓
- The current state of the drum (deterioration) is assumed based on the measurement result of the drum surface potential, and then the result is sent to the image quality control circuit.
↓
- The image quality control changes the image formation condition to make the image density and the line width appropriate.
At this time, the image quality control determines the main charger bias output (effective value).
↓
- The determined effective value of the main charger bias is stored in the NVRAM.

2. Timing of drum surface potential measurement

The drum surface potential is measured with the performance of the image quality control.

The image quality control is performed at the timing as follows.

- When the power is turned ON first thing in the morning or during warming-up after a specified period of time has passed since the last operation
 - When a print job is completed after a specified number of sheets have been printed out
 - When a print job is resumed after a toner cartridge empty status has been released
- * The drum surface potential measurement and whether or not the result reflects to the image quality control can be set in the Setting Mode (08).

9.6 Temperature/humidity detection circuit

9.6.1 Outline

The temperature/humidity detection circuit detects the temperature and humidity inside of the equipment by means of the corresponding sensor so that the printing quality is not changed due to their adverse influence where the equipment is set up, and corrects the output of the auto-toner sensor or similar according to the result.

9.6.2 Construction

The temperature/humidity detection circuit is composed as shown in the figure below. It converts the voltage of each analog signal output from the temperature/humidity sensor into a digital signal by means of the A/D converter embedded in the main CPU on the LGC board. The higher the temperature is, the lower the voltage of the temperature detection signal becomes. The higher the humidity is, the higher the voltage of the humidity detection signal becomes.

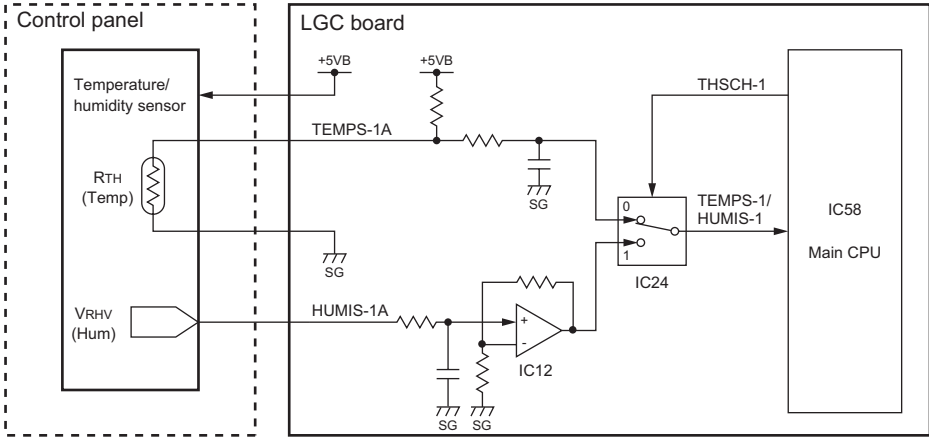

Fig. 9-5

Signal	Function	Low level	High level
THSCH-1	Temperature/humidity switch signal	Temperature detection	Humidity detection
TEMPS-1A	Temperature detection signal (analog)	-	-
HUMIS-1A	Humidity detection signal (analog)	-	-

9.7 Disassembly and Replacement

[A] Main charger

- (1) Take off the toner cartridge drive unit.
(P.11-12 "[A] Toner cartridge drive unit")
- (2) Remove 3 screws and take off the left inner cover.
- (3) Remove 1 stepped screw and pull out the main charger.

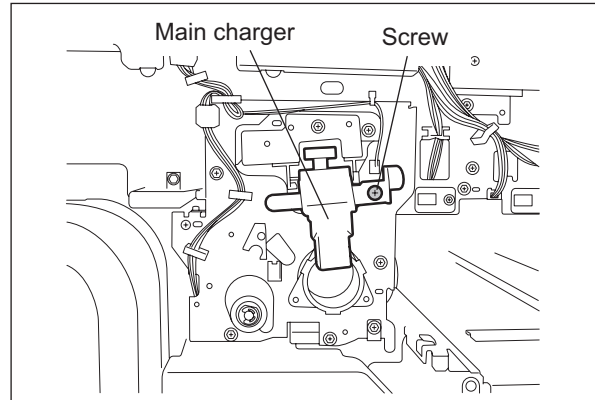

Fig. 9-6

- (4) Press the button to release the tension of the main charger grid, and then release the hook to remove the grid.

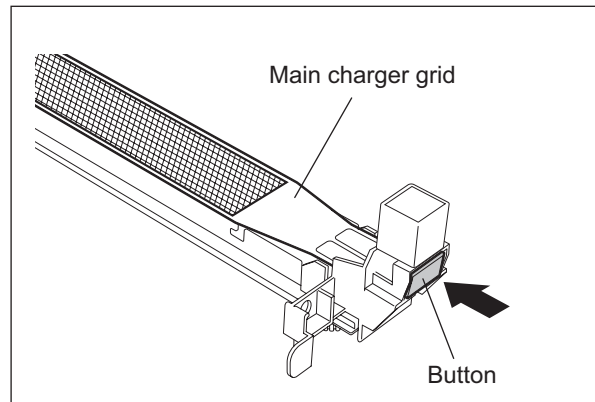

Fig. 9-7

- (5) Take off 1 finger and then the front terminal cover.

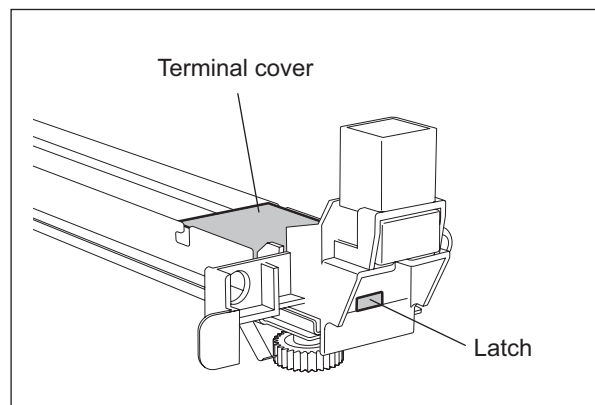

Fig. 9-8

- (6) Take off 2 fingers and then the rear terminal cover.

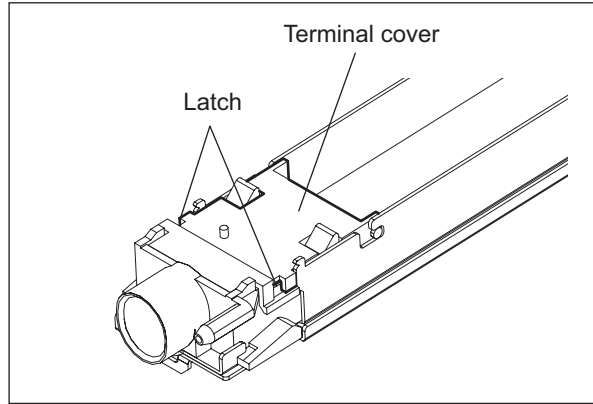

Fig. 9-9

- (7) Pull up the terminal, remove the spring and release the hook on the rear side to take off the charger wire.

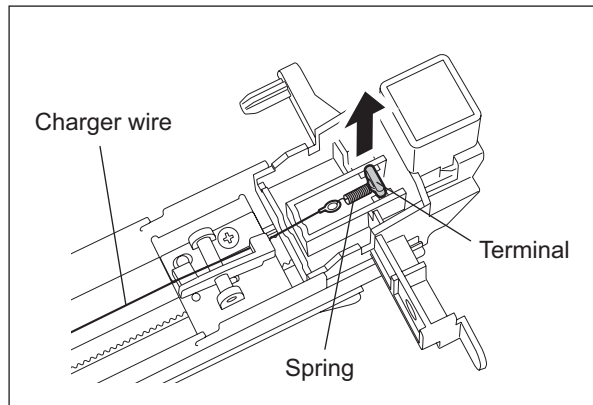

Fig. 9-10

- (8) Remove 1 screw and take off the cleaning pad.

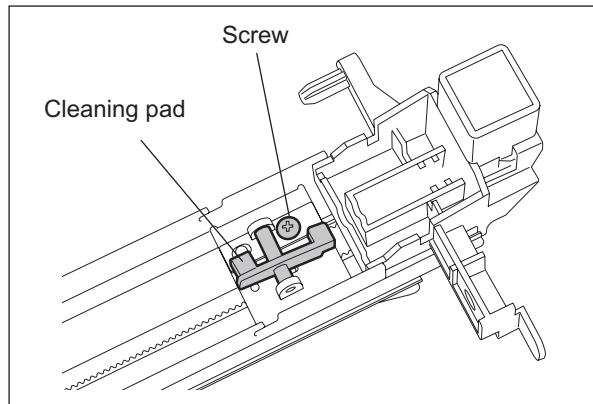

Fig. 9-11

Note:

When assembling the main charger, install it so that the charger wire passes through the center of the pad.

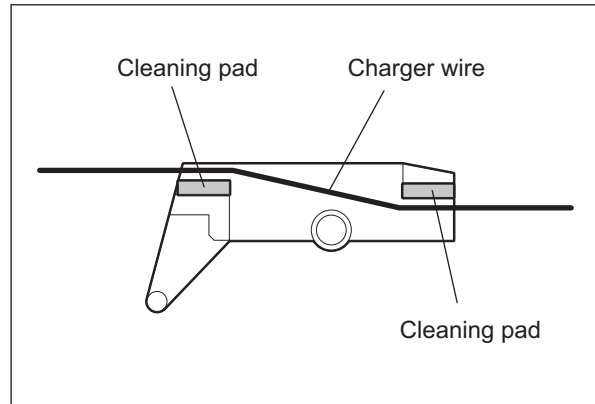

Fig. 9-12

[B] Wire cleaner drive unit / Wire cleaner drive motor (M12)

- (1) Take off the cleaner unit.
(P.10-7 "[A] Cleaner unit")
- (2) Disconnect 1 connector, remove 1 screw, and then take off the wire cleaner drive unit.

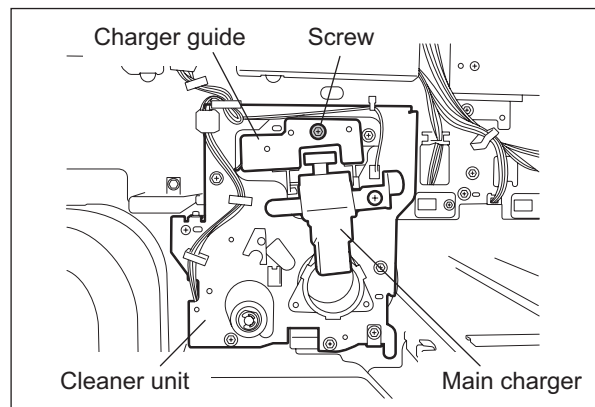

Fig. 9-13

- (3) Disconnect 1 connector, remove 1 screw, and then take off the wire cleaner drive motor (M12) with the bracket.
- (4) Remove 2 screws and take off the wire cleaner drive motor.

Note:

Pay attention to the size (length) of the screws. If incorrect ones are used, the motor could be damaged.

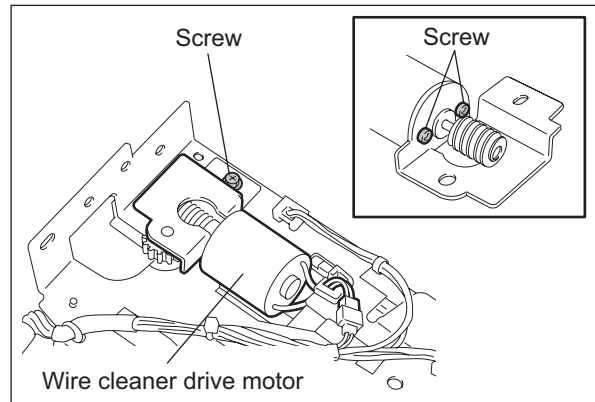

Fig. 9-14

- (5) Disconnect 2 connectors, remove 1 screw, and then take off the wire cleaner position detection switch (SW4).

Note:

Push the switch in the direction of arrow A to fix it. Also, carefully insert the connector into the terminal of the color of the harness, and then bend the terminal 45°.

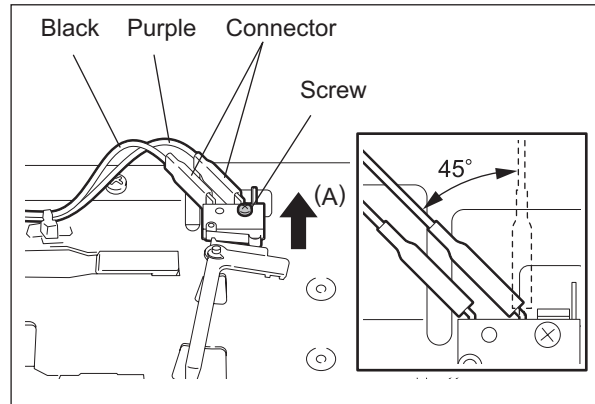

Fig. 9-15

[C] Discharge LED (ERS)

- (1) Take off the wire cleaner drive unit.
(P.9-11 "[B] Wire cleaner drive unit / Wire cleaner drive motor (M12)")
- (2) Disconnect 1 connector.

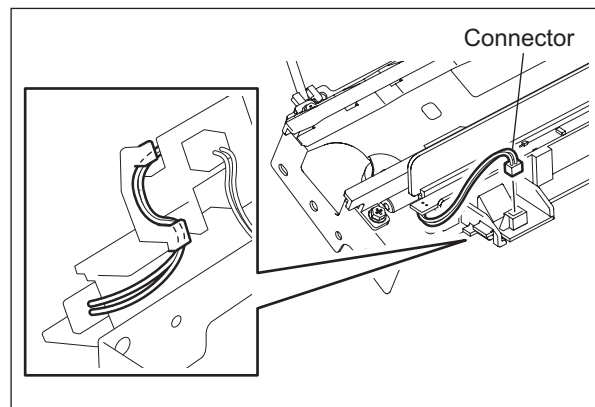

Fig. 9-16

- (3) Lift the connector side of the discharge LED slightly to release the lock, and then slowly pull out the discharge LED from the guide.

Note:

Assemble the discharge LED so that all fingers of the guide are hooked.

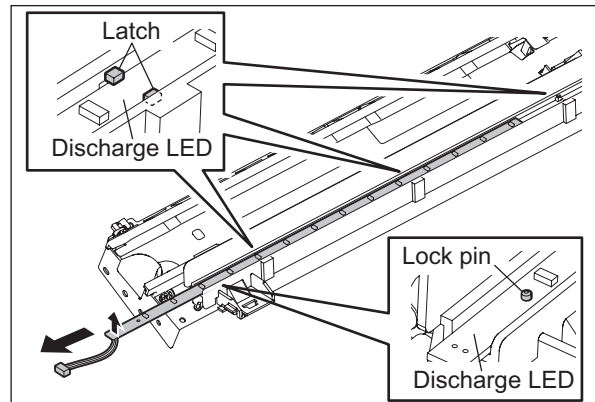

Fig. 9-17

[D] Drum surface potential sensor (S13)

- (1) Take off the cleaner unit.
(P.10-7 "[A] Cleaner unit")
- (2) Disconnect 1 connector, remove 1 screw, and then take off the sensor bracket.

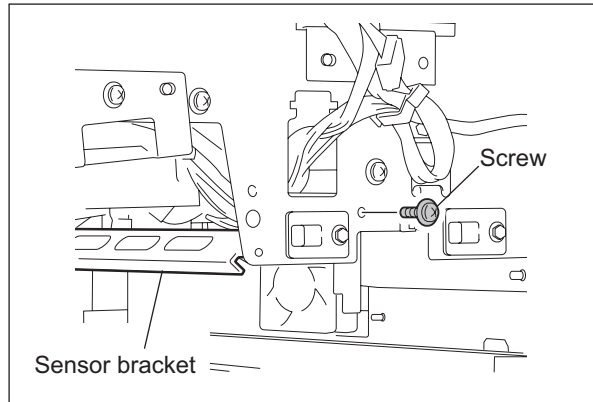

Fig. 9-18

- (3) Disconnect 1 connector, remove 1 screw, and then take off the surface potential sensor (detection section).

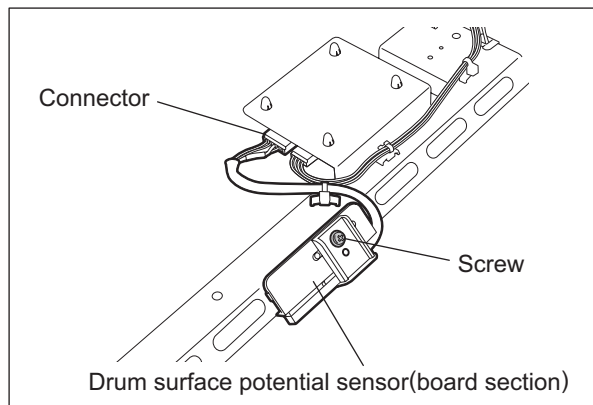

Fig. 9-19

- (4) Disconnect 1 connector, release 4 lock supports, and then take off the surface potential sensor (board section).

Note:

The drum surface potential sensor consists of the detection section and the board section as a set.

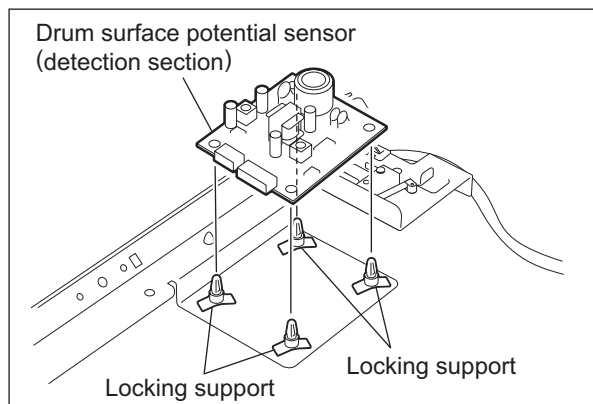

Fig. 9-20

[E] Temperature/humidity sensor (S7)

- (1) Take off the control panel unit.
(☞ P.5-12 "[A] Control panel unit")
- (2) Disconnect 1 connector, remove 1 screw, and then take off the temperature/humidity sensor.

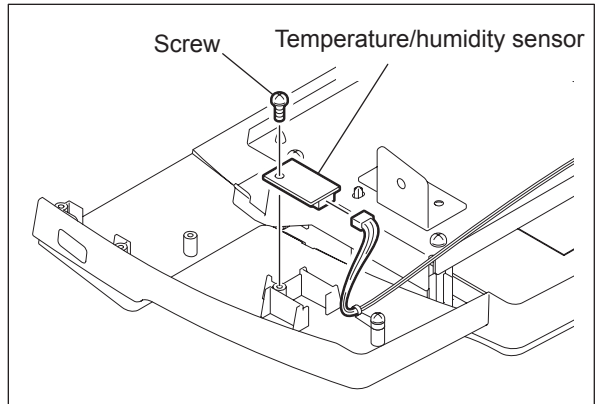

Fig. 9-21

[F] Exhaust duct

- (1) Take off the wire cleaner drive unit.
(☞ P.9-11 "[B] Wire cleaner drive unit / Wire cleaner drive motor (M12)")
- (2) Pull out the transfer/transport unit.
- (3) Take off the left upper cover.
(☞ P.2-44 "[I] Left upper cover")
- (4) Open the left lower cover (exit cover).
- (5) Disconnect 3 connectors and release the harness from 4 clamps.
- (6) Remove 1 screw, slide the exhaust duct to the front side to release the hook, and then pull it out toward you.

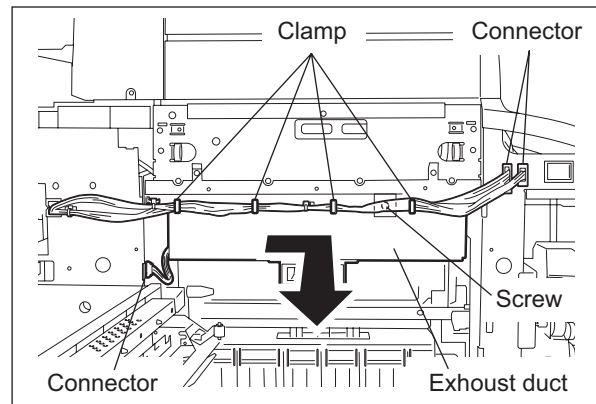

Fig. 9-22

[G] Duct out fan (M27) / Exit section cooling fan (M29)

- (1) Take off the exhaust duct.
(☞ P.9-14 "[F] Exhaust duct")
- (2) Disconnect 1 connector and pull out the duct out fan.
- (3) Disconnect 1 connector, remove 2 screws, and then take off the exit section cooling fan with the bracket.
- (4) Remove 2 screws and take off the exit section cooling fan from the bracket.

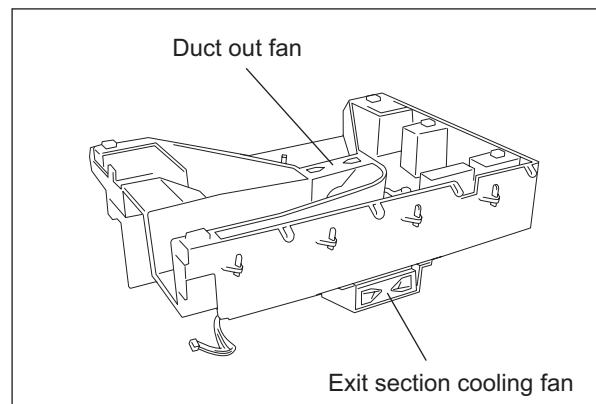

Fig. 9-23

[H] Ozone filter

- (1) Remove 1 screw on the left face of the rear cover and pull out the ozone filter.
- (2) Remove the ozone filter from the case.

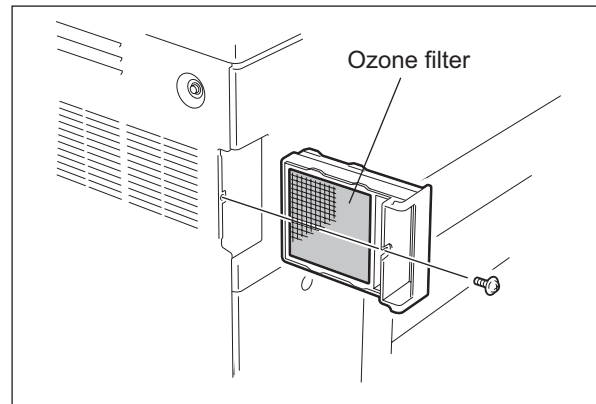

Fig. 9-24

10. DRUM/CLEANER UNIT

10.1 Construction

This chapter describes the drum and cleaner unit. The cleaner unit consists of the drive section, cleaning section, recovered toner transport section, image quality sensor (S14), drum separation finger, etc.

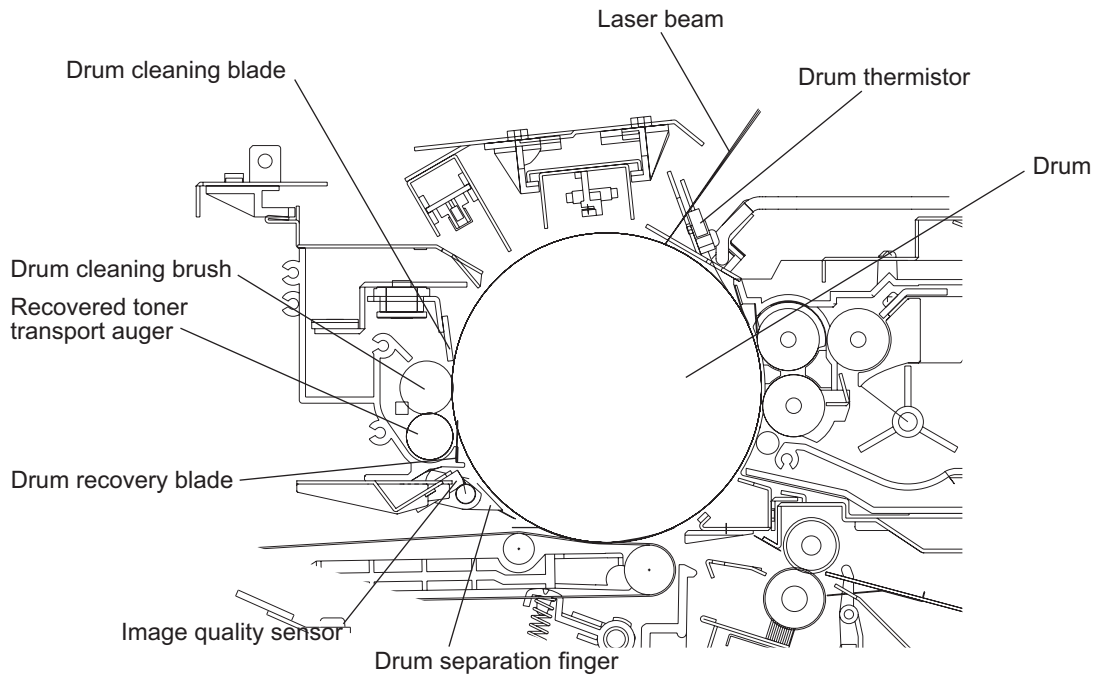

Fig. 10-1

10.2 Functions

- (1) Drum
It is a cylindrical aluminum base on which an organic photosensitive material (photoconductor) is thinly applied. A photoconductor becomes insulative (high electric resistance) at dark places (out of the light), while it becomes conductive (low electric resistance) under the light, so it is called a photoconductor.
- (2) Drum cleaning blade
It is made of polyurethane rubber. It scrapes off the residual toner on the drum surface by being pressed against the drum with a certain pressure by the weight. You can separate the blade from the drum by turning the cam manually in order to release the pressure.
- (3) Drum recovery blade
It catches the toner scraped off by the drum cleaning blade.
- (4) Recovered toner transport auger
It corrects and transfers the toner scraped off by the drum cleaning blade and caught by the drum recovery blade. The toner is transferred to the recycle unit to be reused.
- (5) Drum separation finger
It separates paper not separated from the drum on the transfer belt.
- (6) Image quality sensor (S14)
It detects the adhered toner amount from the reflective rate for the test pattern formed on the drum in order to maintain a proper image density and line width.
- (7) Drum thermistor (THM5)
Since the charging amount changes depending on the temperature of the drum surface, the drum thermistor detects the temperature of the drum surface.
- (8) Drum cleaning brush
It eliminates the paper dust and extraneous substances adhering to the drum surface after the paper has been separated. It also decreases the friction of the drum cleaning blade to lengthen its life span, which improves the image reliability.
- (9) Drum motor (M11)
It drives the drum through the timing belt, pulleys and couplings.
- (10) Cleaning brush driving motor (M13)
It drives the drum cleaning brush and recovered toner transport auger through the timing belt, pulleys and gears.
- (11) Drum separation finger solenoid (SOL1)
It works only when the leading edge of the paper is passing the drum. The drum separation finger is pressed against the drum by this solenoid and the finger separates the paper forcibly from the drum.

10.3 Drum Temperature Detection Circuit

The drum temperature detection circuit is composed as shown in the figure below. It converts the input voltage from the drum thermistor into a digital signal by means of the A/D converter embedded in the main CPU on the LGC board. The drum thermistor is an element whose resistance value is smaller when the temperature is higher. Therefore, when the temperature becomes higher, the input voltage to the main CPU becomes lower.

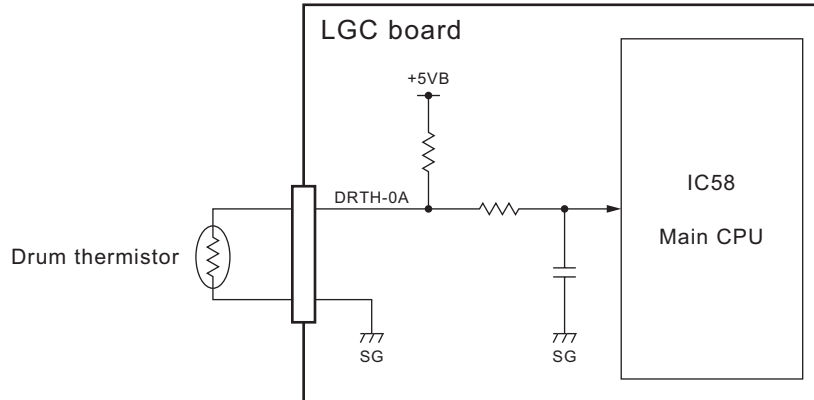

Fig. 10-2

10.4 Image Quality Control

10.4.1 Outline

This equipment performs image quality control with the image quality sensor. Image quality control is for altering the image formation condition to minimize the changing of the image density and line width caused by the setting environment for the equipment and the life of consumables.

The image quality sensor detects the density of the test pattern developed on the drum, and the image formation condition is changed depending on the result.

10.4.2 Construction

The construction of the control circuit is as follows.

- Image quality sensor:
This sensor emits the light corresponding to the voltage of the light source amount signal output from the control section onto the drum, and outputs the voltage corresponding to the reflected light amount of the drum and the test pattern (toner image) on the drum.
- Control section (LGC board):
This section performs image quality control mainly with the main CPU, which outputs the light source amount signal (CTDVR-1A) of the image quality sensor by a D/A converter, and converts the reflected light amount signal (CTDS-1) into a digital signal by mean of the A/D converter embedded in the main CPU and reads it, and then sets the image formation condition based on the read result.
- Image formation process system:
This system consists of the process of charging, laser exposing and developing. Each process is operated based on the image formation condition set by the control section. When image quality control is performed, the laser unit exposes the test pattern on the drum.

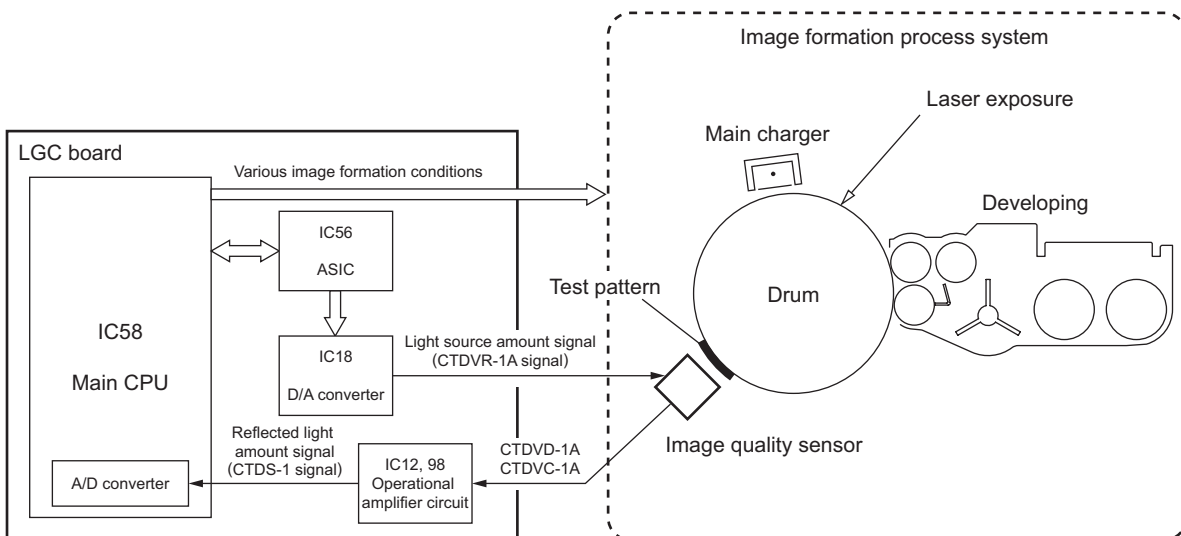

Fig. 10-3

10.4.3 Principle of Image Quality Sensor

The image quality sensor applies the light to the drum and test pattern (toner image) developed on the drum and outputs the voltage corresponding to its reflected light amount.

Toner amount on the drum is calculated from the reflected light amount obtained by this sensor.

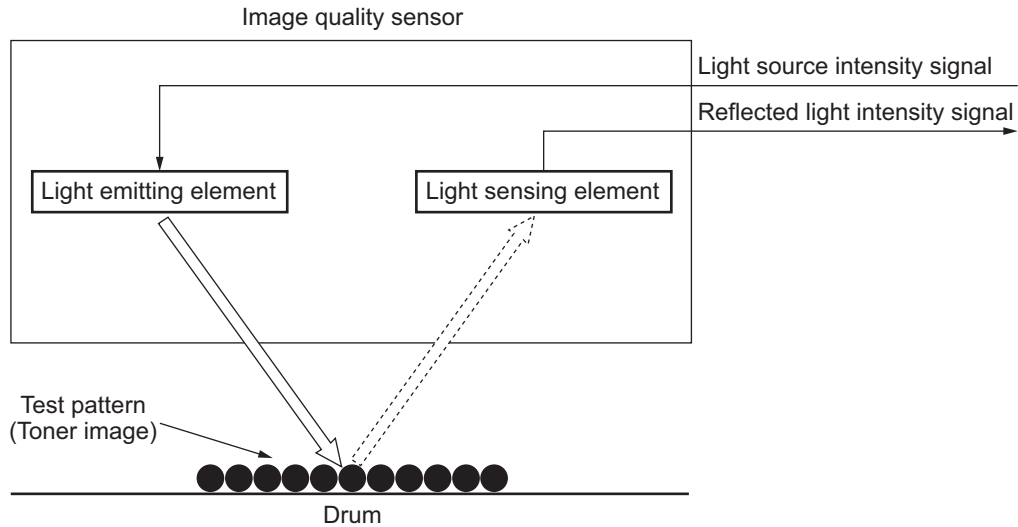
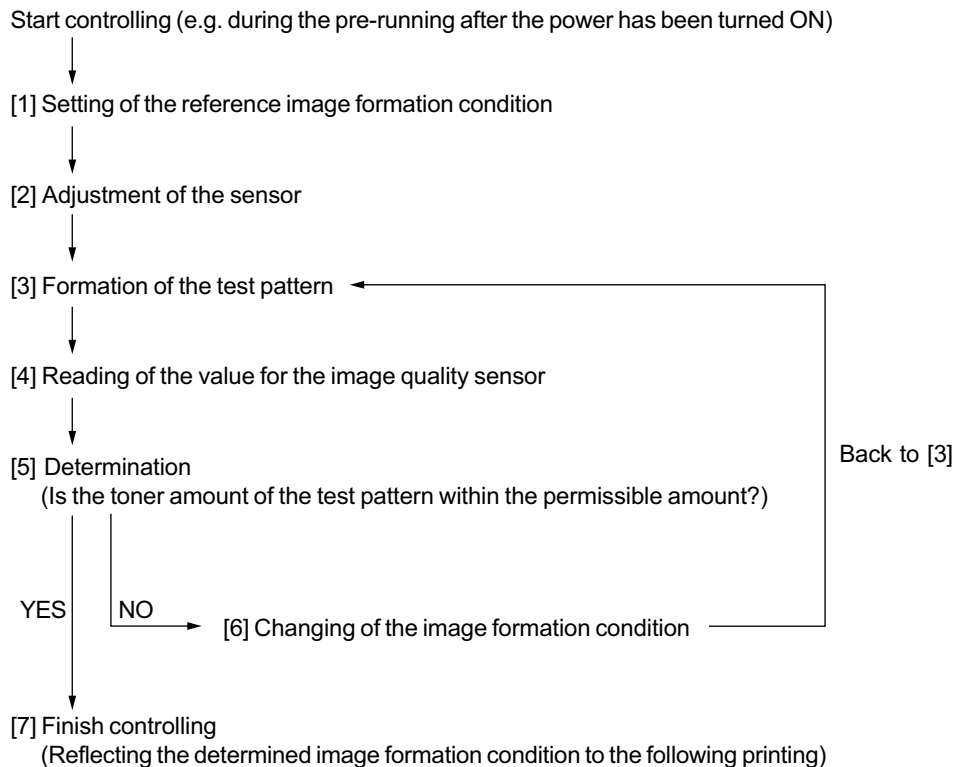

Fig. 10-4

10.4.4 Flow of control



10.5 Drum motor control circuit

The drum motor control circuit is composed as shown in the figure below. It drives the drum motor by the drive signal output from the main CPU on the LGC board, and rotates the drum. The drum motor is a stepping motor driven by the pulse signal (DRMA-0, DRMB-0, DRMA-B-0, DRMBB-0) output from the motor driver. These pulse signals are formed based on the reference clock signal (DRCLK-0), and output only when the enable signal (DRMEN-1) is L level. Also, the rotational speed of the motor is switched by changing the frequency of the reference clock signal (DRCLK-0) while its rotational direction is switched with the motor rotational direction switch signal (DRMCW-0).

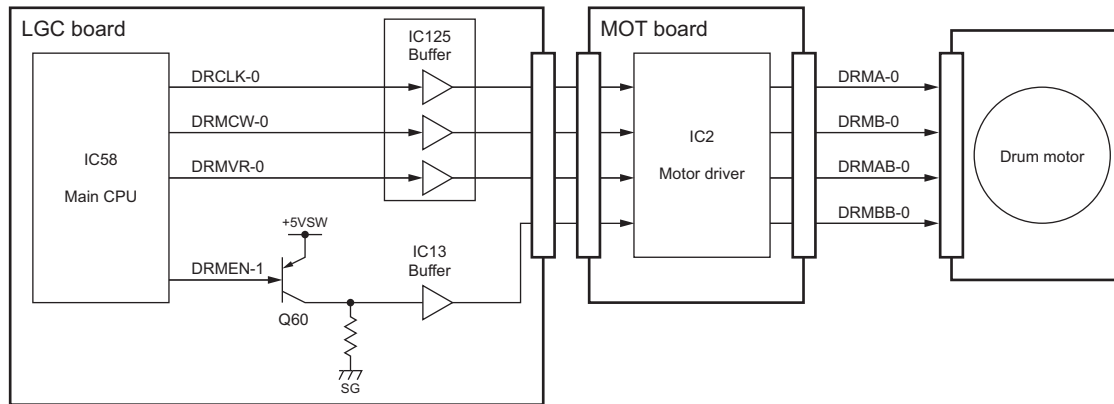



Fig. 10-5

Drum motor drive signal

Signal				Motor status
DRCLK-0	DRMEN-1	DRMVR-0	DRMCW-0	
Pulse signal	L	L	L	Forward rotation when accelerating/ decelerating
	L	L	H	Reverse rotation when accelerating/ decelerating
	L	H	L	Forward rotation at a constant speed
	L	H	H	Reverse rotation at a constant speed
-	H	-	-	Stop

10.6 Disassembly and Replacement

[A] Cleaner unit

- (1) Take off the main charger.
( P.9-9 "[A] Main charger")
- (2) Disconnect 1 connector and remove 2 screws to pull out the cleaner unit.

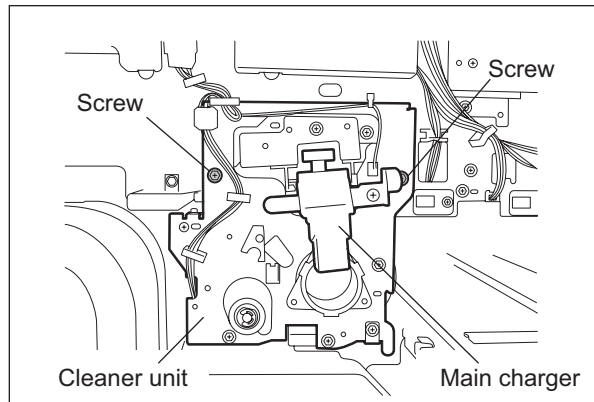



Fig. 10-6

[B] Drum thermistor (THM5) and Drum

- (1) Take off the cleaner unit
( P.10-7 "[A] Cleaner unit")
- (2) Disconnect 1 connector and remove 1 screw to take off the drum thermistor with its bracket.
- (3) Remove 1 screw to take off the drum thermistor.

Note:

When installing the thermistor, tighten it with the 0.2-0.6N•m torque.

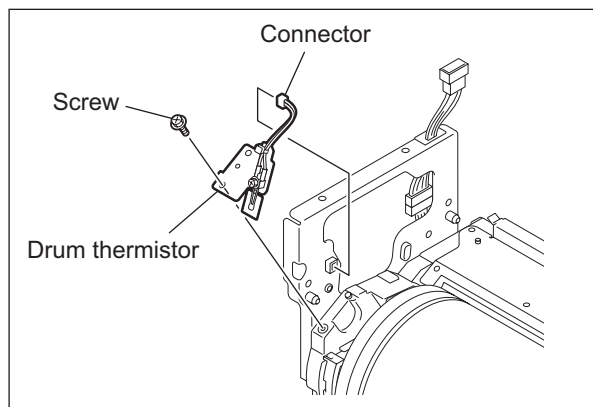

Fig. 10-7

- (4) Turn the cam to release the pressure of the cleaning blade.
- (5) Remove 3 screws to take off the drum shaft.

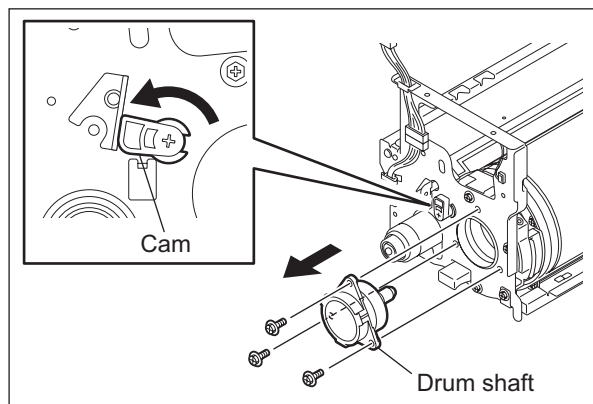

Fig. 10-8

(6) Take out the drum upward.

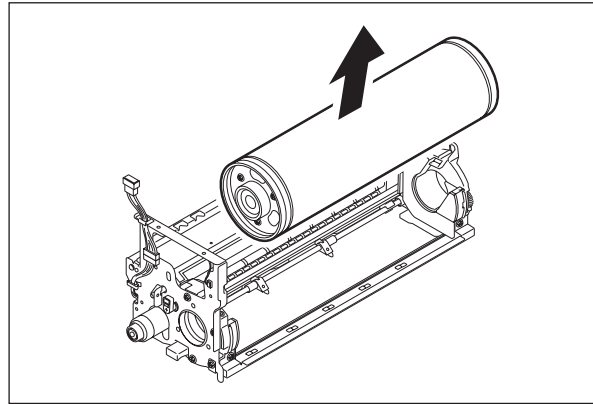

Fig. 10-9

(7) Remove 3 screws to take off the flange on the front side.

(8) Pull out the drum upward.

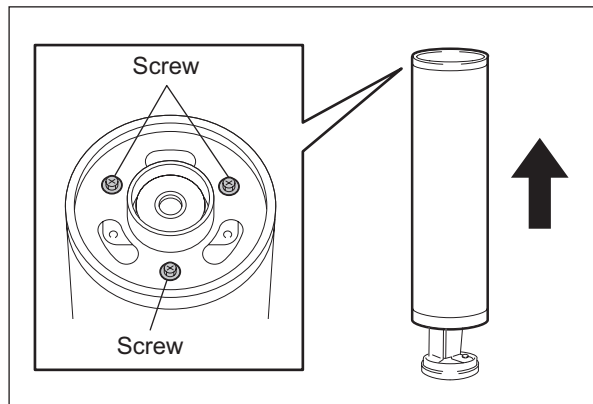

Fig. 10-10

<<Precaution when installing the drum shaft>>

- Make sure that the gap plate is not caught with the drum shaft.
- Be sure to install the drum shaft and cleaner frame without a gap.
- No foreign matter must be attached on the cleaner stay.

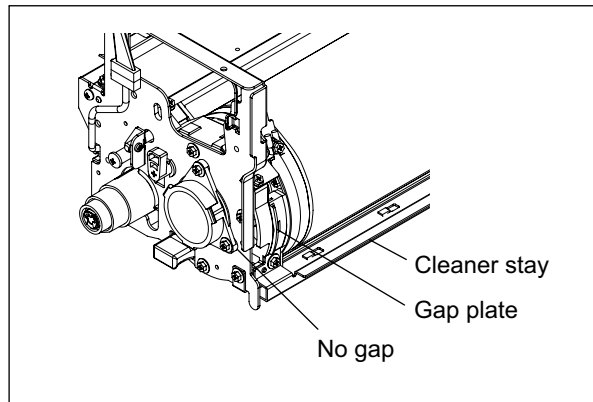

Fig. 10-11

[C] Cleaning blade

- (1) Take off the drum.
(☞ P.10-7 "[B] Drum thermistor (THM5) and Drum")
- (2) Remove 4 screws to take off the cleaner top cover.

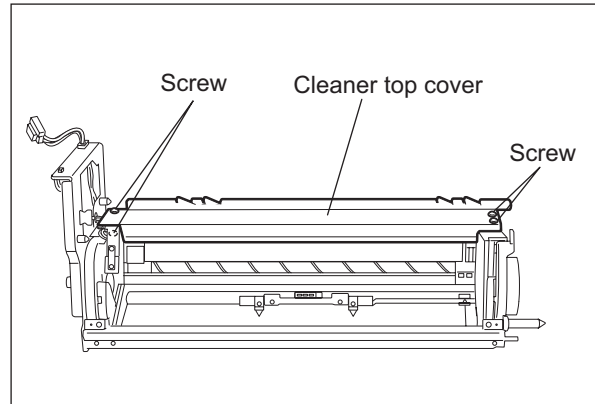

Fig. 10-12

- (3) Remove 1 screw to take off the cleaning blade by holding both sides of the plate.

Note:

Do not touch the edge of the cleaning blade.

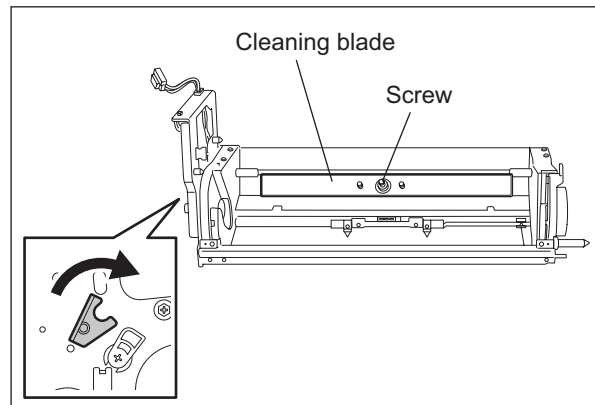

Fig. 10-13

[D] Recovery blade

- (1) Take off the cleaning blade.
(☞ P.10-9 "[C] Cleaning blade")
- (2) Separate the recovery blade gently.

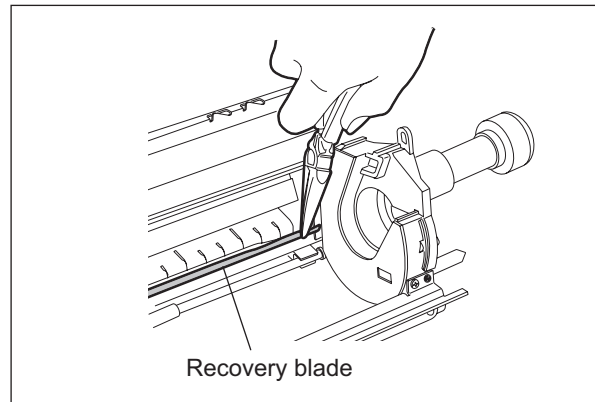

Fig. 10-14

Notes:

1. When replacing the recovery blade, be sure to separate it completely because it is attached with the two-sided adhesive tape.
2. Attach the recovery blade by pushing its lower edge against the step of the cleaner frame. (A in the figure on the right)

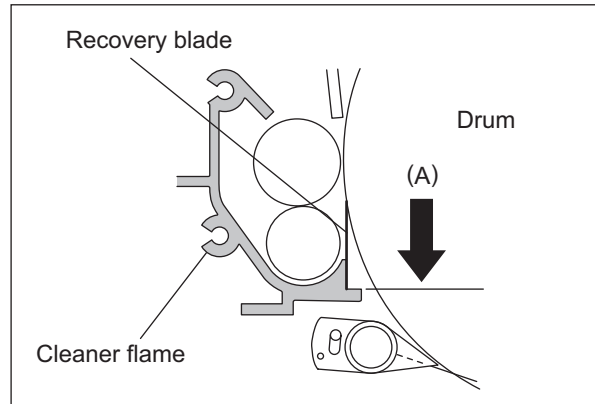

Fig. 10-15

[E] Cleaning brush

- (1) Take off the drum.
(P.10-7 "[B] Drum thermistor (THM5) and Drum")
- (2) Pull out the shaft held on the rear side to take out the cleaning brush.

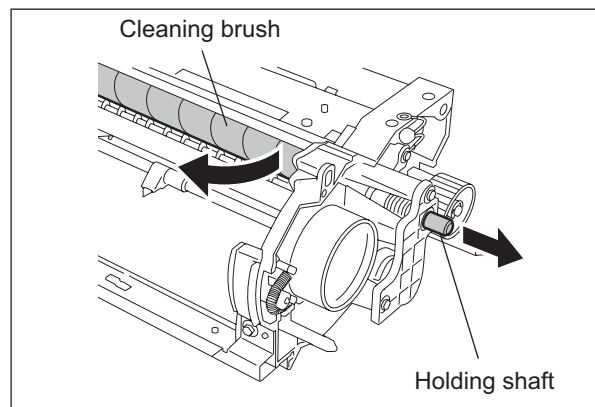

Fig. 10-16

[F] Image quality sensor (S14)

- (1) Take off the cleaner unit.
(P.10-7 "[A] Cleaner unit")
- (2) Disconnect 1 connector and remove 2 screws to take off the image quality sensor.

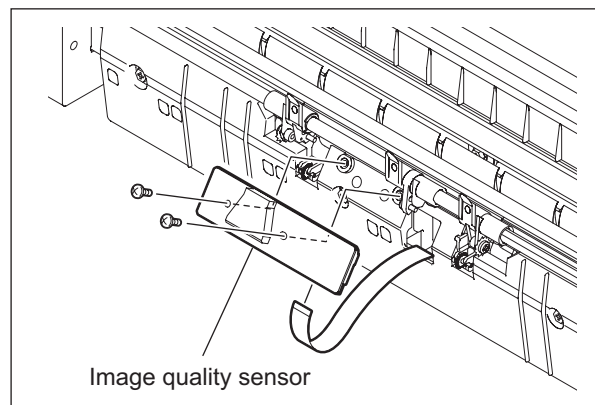

Fig. 10-17

Note:

Do not touch the board parts (especially the 3 variable resistors shown in the figure) of the image quality sensor.

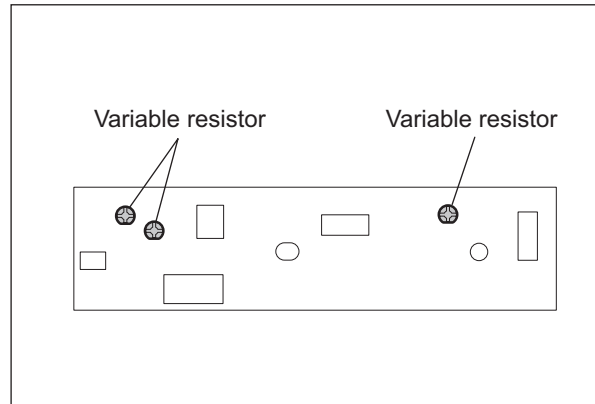

Fig. 10-18

[G] Drum separation finger

- (1) Take off the drum.
(P.10-7 "[B] Drum thermistor (THM5) and Drum")
- (2) Take off the image quality sensor.
(P.10-10 "[F] Image quality sensor (S14)")
- (3) Remove 2 screws to take off the plate on the rear side.

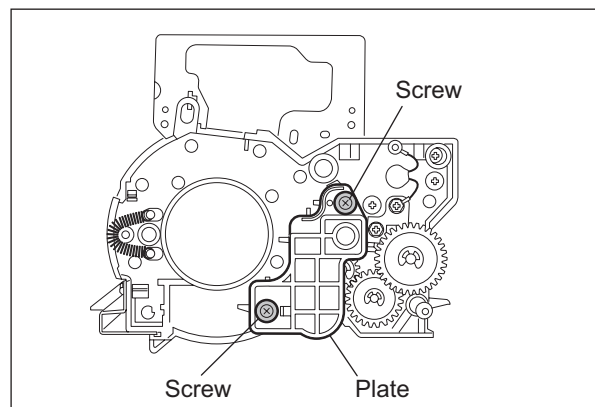

Fig. 10-19

- (4) Remove the E-ring to take off the cam.

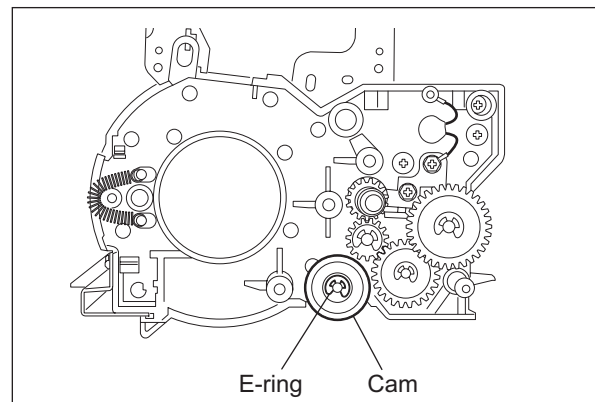

Fig. 10-20

- (5) Take off the shaft of the separation finger by sliding it to the front side.
- (6) Remove 1 screw each to pull out the separation finger from the shaft.
- (7) Remove 1 E-ring and 1 screw, and then take off the separation finger (in the middle) from the shaft.

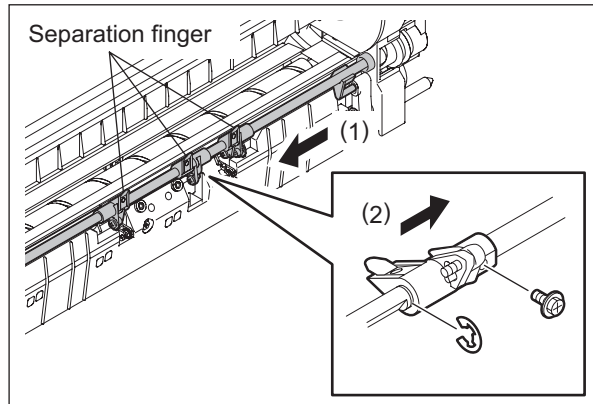

Fig. 10-21

Notes:

1. When assembling, be sure that the arm is in the hole of the separation finger.

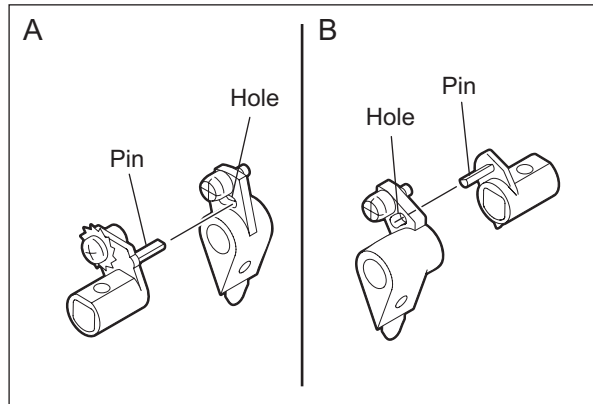

Fig. 10-22

2. Make sure you assemble the drum separation finger with the weight screws in the correct direction.
3. Be sure to install the separation finger in the correct position because the shape of the separation finger in the middle and on the outer side is different.

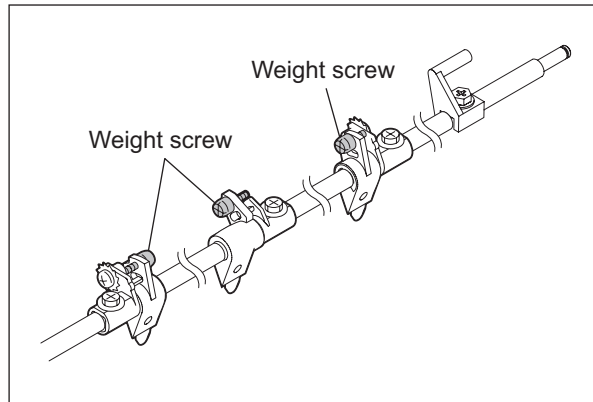

Fig. 10-23

[H] Drum motor (M11) / Motor driving PC board (MOT)

- (1) Take off the rear cover, SYS board and then hard disk with its bracket.
- (2) Remove 3 screws to take off the drum wheel.

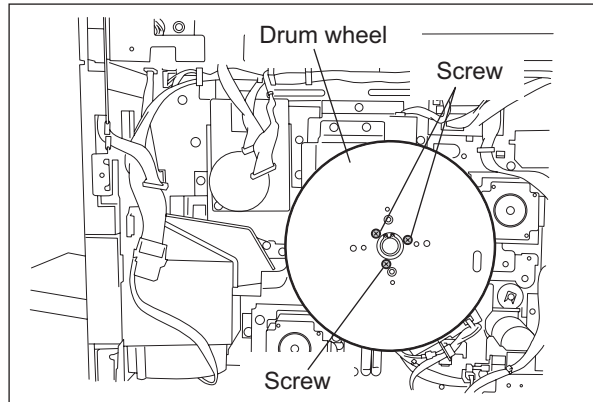

Fig. 10-24

- (3) Disconnect 1 connector and remove 3 screws to take off the drum motor with its bracket.

Note:

When installing the drum motor, tighten the screw while the bracket is pushed against the motor in the direction of the arrow.

- (4) Remove 3 screws to take off the drum motor.

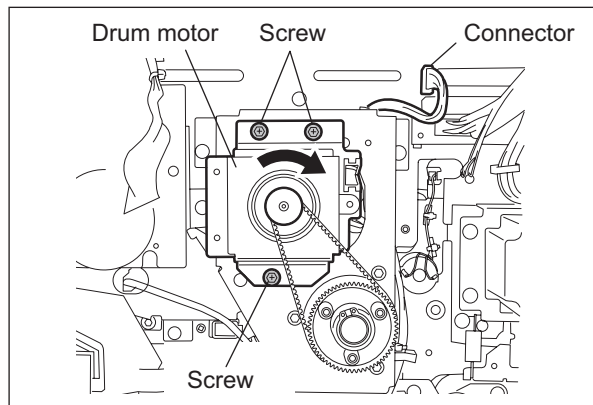

Fig. 10-25

[I] Cleaning brush drive motor (M13) / Drum separation finger solenoid (SOL1)

- (1) Take off the exhaust duct.
(P.9-14 "[F] Exhaust duct")
- (2) Remove 1 screw and take off the stay.

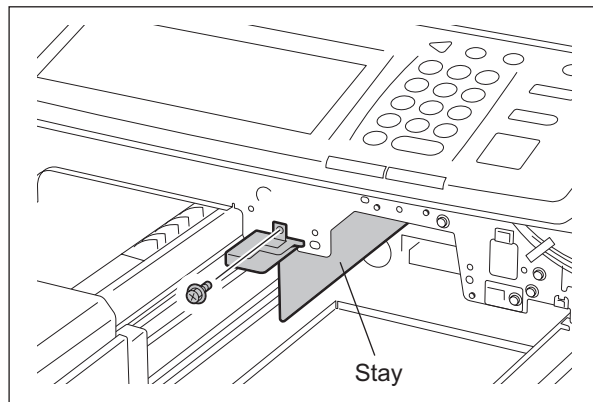

Fig. 10-26

- (3) Disconnect 2 connectors, remove 3 screws and take off the motor and solenoid with the bracket.

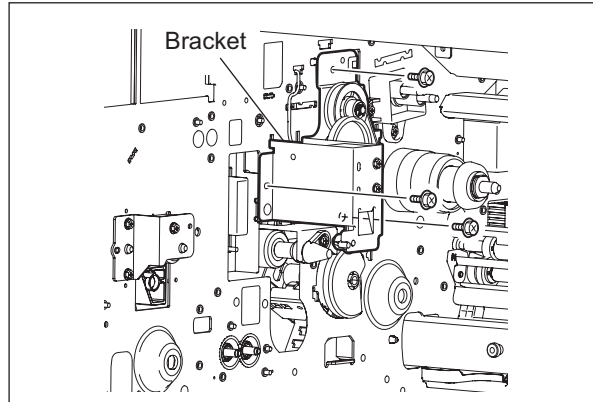

Fig. 10-27

- (4) Remove 2 screws and take off the cleaning brush drive motor.
- (5) Remove 2 screws and take off the drum separation finger solenoid.

Note:

Pay attention to the size (length) of the screws. If incorrect ones are used, the motor could be damaged.

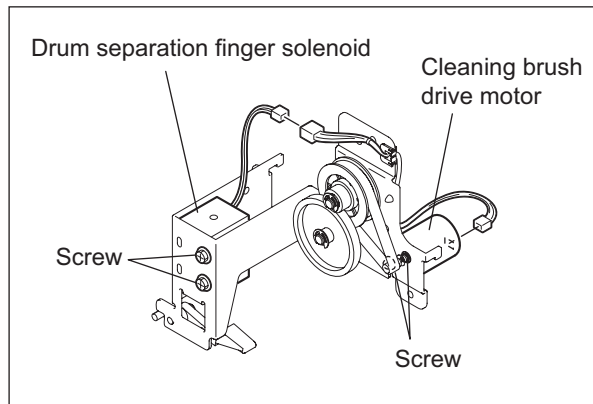

Fig. 10-28

11. DEVELOPER UNIT

11.1 Construction

This chapter describes about the following units related to the development process, parts, control circuit, etc.

- Toner cartridge drive unit
- Toner recycle unit
- Developer unit
 - Developer material
 - Mixer unit
 - Paddle
 - Transport sleeve (magnetic roller)
 - Upper/Lower developer sleeve
 - Doctor blade
 - Auto-toner sensor
 - Scattered toner recovery roller
- Developer unit drive section

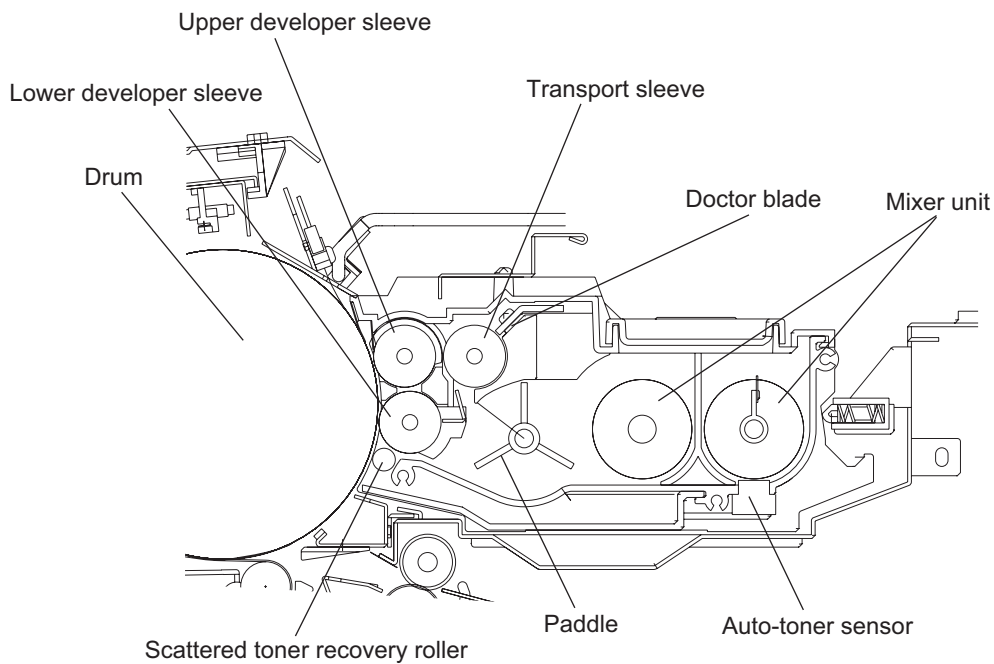

Fig. 11-1

11.2 Functions

(1) Toner cartridge

The toner cartridge is filled with the toner and the toner is supplied to the developer unit. In this equipment, the toner cartridge can be replaced without stopping any operation when the toner cartridge becomes empty during printing.

The remaining amount of the toner can be detected in the following 3 steps.

- Detecting that the toner in the toner cartridge has decreased
The drive count of the new toner transport motor (M6) theoretically can be a detection of decreased toner amount in the toner cartridge.
- Detecting that the toner cartridge is empty
The toner cartridge empty sensor (S10) detects that the toner cartridge has become empty. This sensor is installed on the toner cartridge holder, and detects the presence of the toner in the cartridge by the contact of the toner to the sensor surface.
Even after the cartridge is detected as empty, a small amount of toner still remains in the sub-hopper. This remaining toner enables to print approx. 2,000 sheets of A4/LT paper so that the toner cartridge can be replaced during this printing, without stopping the printing operation.

When the front cover (upper) is opened for the cartridge replacement during printing, the recycle toner transport motor (M8) continues running but the new toner supply motor (M5) is stopped. While the cover is opened, the equipment exits only a number of sheets specified in the code 08-1520. When the number of sheets being exited exceeds this specified number, the printing is interrupted. When the cover is closed, the printing is resumed.

- Detecting lowered toner density in the developer unit (printing is disabled)
The auto-toner sensor (S12) detects that the toner in the developer unit has been consumed by detecting the toner density in the unit.

Note:

Calculation of the pixel counter is not used for the above detection of the amount of toner remaining.

(2) Toner cartridge drive unit

The toner cartridge drive unit consists of the toner cartridge holder which rotates the toner cartridge, and the sub-hopper.

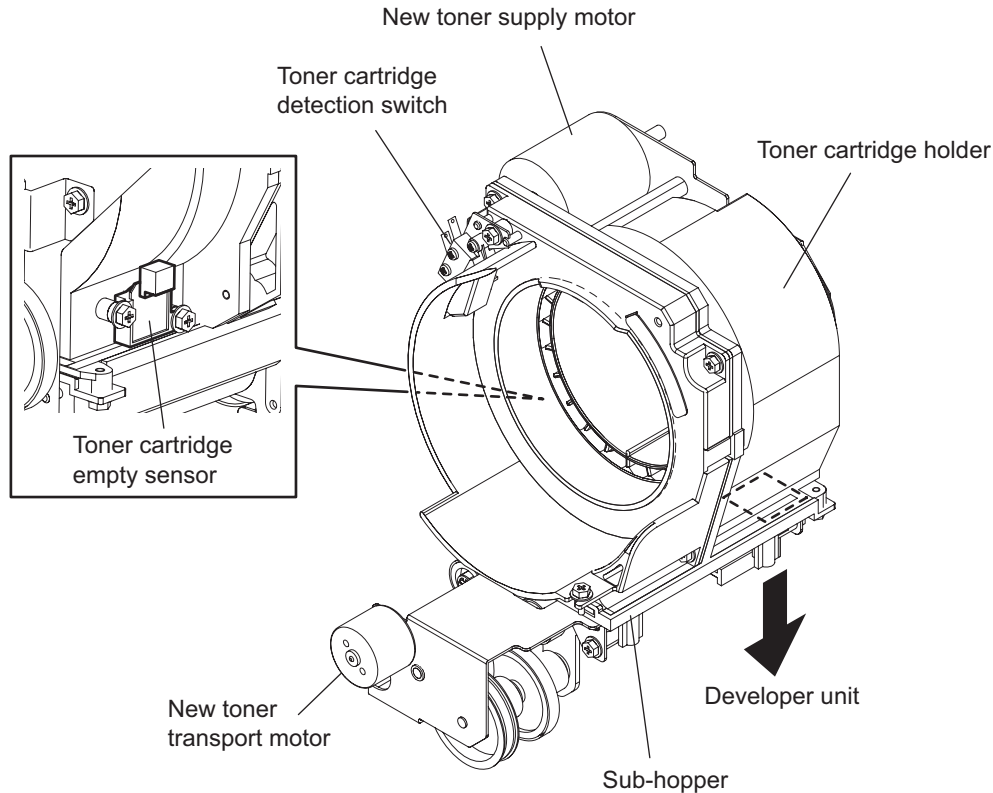

Fig. 11-2

- **Toner cartridge holder**
The toner cartridge holder includes a coupling to hold the toner cartridge, the new toner supply motor (M5) to rotate the cartridge, the toner cartridge detection switch (SW2) to detect the rotation of the cartridge, and the toner cartridge empty sensor (S10) to detect the empty status of the cartridge.
- **New toner supply motor (M5)**
The drive of the new toner supply motor (M5) is transmitted to the toner cartridge holder through the pulley, timing belt and gear, and thus the coupling of the holder is rotated. The cartridge is rotated along with the rotation of the coupling to supply the toner.
- **Toner cartridge detection switch (SW2)**
This switch detects the rotation of the toner cartridge.
- **Toner cartridge empty sensor (S10)**
This sensor is a piezoelectric type sensor which detects the empty status of the cartridge. When the toner is adhered on the surface of this sensor, a correct detection cannot be performed. Therefore a blade to scrape off the toner adhered on the sensor surface is equipped on the toner cartridge holder. This blade is rotated by the drive of the new toner supply motor (M5).
- **Sub-hopper**
The sub-hopper consists of the paddle to mix the toner transported from the cartridge, and the auger to transport the toner to the developer unit.

- New toner transport motor (M6)
The new toner transport motor (M6) drives the paddle and auger of the sub-hopper through the pulley, timing belt and gear. Therefore the drive of the toner cartridge holder differs from that of the sub-hopper.

(3) Toner recycling unit

A toner recycling system is adopted in this equipment. The toner, which has been recovered from the drum surface by the drum cleaner, is transported to the developer unit by the toner recycling unit, and thus the transported toner is recycled.

This unit consists of the recycle toner hopper to collect and mix the recycle toner, and the pipe to transport the recycle toner from the drum cleaner to the recycle toner hopper.

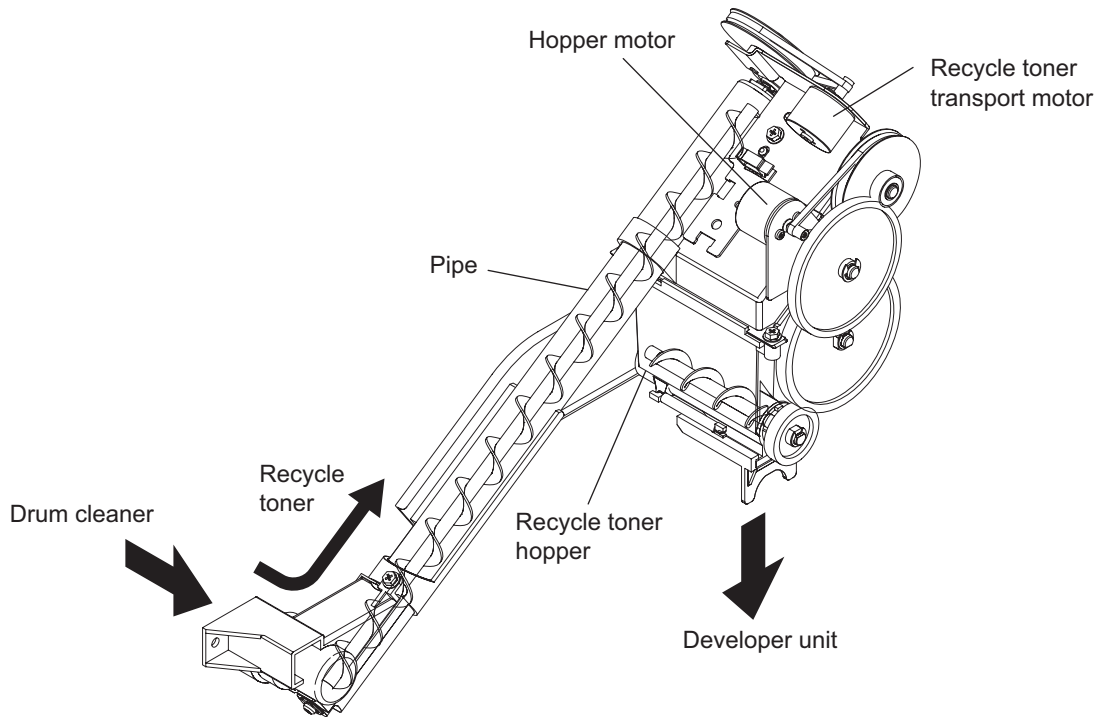

Fig. 11-3

- Recycle toner hopper
This hopper includes the paddle and auger driven by the hopper motor (M7).
- Pipe
The auger is equipped in the pipe to transport the toner. This auger is driven by the recycle toner transport motor (M8).

(4) Developer unit

The developer unit of the e-STUDIO755/855 has a different structure (driving gear) from that of e-STUDIO555/655 due to its copy speed. The developer unit of the e-STUDIO555/655 has a protrusion on its rear side to prevent a wrong installation.

- Developer material

The developer material consists of the carrier and toner. The carrier is a conductive ferrite whose size is approx. 65 μm . The toner consists of approx. 12.5 μm size resin particles. The developer material requires a periodic maintenance since it deteriorates in a long-term use and print images may be influenced by this deterioration.

- Mixer

The carrier and toner generate a friction when the developer material is mixed. The carrier is positively charged while the toner is negatively charged, and thus the toner is adhered on the drum by static electricity caused by this charging.

- Paddle

The paddle supplies the developer material mixed by the mixer to the transport sleeve. Also the paddle returns the developer material separated from the lower developer sleeve to the mixer section.

- Transport sleeve / Developer sleeve (Magnetic roller)

These sleeves are aluminum rollers which include a magnet in each. This magnetic force attracts the developer material to form a magnetic brush. This magnet is fixed, therefore only the sleeves are rotated. By this rotation, the developer material is transported from the transport sleeve to the developer sleeve, and the magnetic brush formed by the developer sleeve sweeps over the drum surface, thus the development is performed.

- Doctor blade

The doctor blade controls the amount of the developer material transported from the transport sleeve so that the magnetic brush of the developer material can contact with the drum surface properly.

- Auto-toner sensor (S12)

The ratio of the carrier and toner (= toner density) in the developer material should constantly be fixed at a certain level for a correct image printing. The auto-toner sensor (S12) detects the inclusion ratio of the toner in the developer material with a magnetic bridge circuit. When the toner becomes insufficient, the new toner supply motor (M6) and the hopper motor (M7) are driven to supply the toner from the toner cartridge and the recycle toner hopper.

- Scattered toner recovery roller

This roller catches the toner scattered from the developer sleeve and puts the caught toner into the developer unit, so that the scattered toner will not fall out of the developer unit.

(5) Developer unit drive section

The developer unit is driven by the developer unit motor (M10).

(6) Developer unit fan (M31) / Toner filter

The developer unit fan (M31) suctions the toner scattered out of the developer unit, and the suctioned toner is then collected at the toner filter through the duct.

(7) Duct in fan (M30)

This fan cools down the developer unit.

(8) Developer unit detection switch (SW3)

This switch detects whether the developer unit is installed or not.

11.3 Developer Unit Drive

Developer unit drive

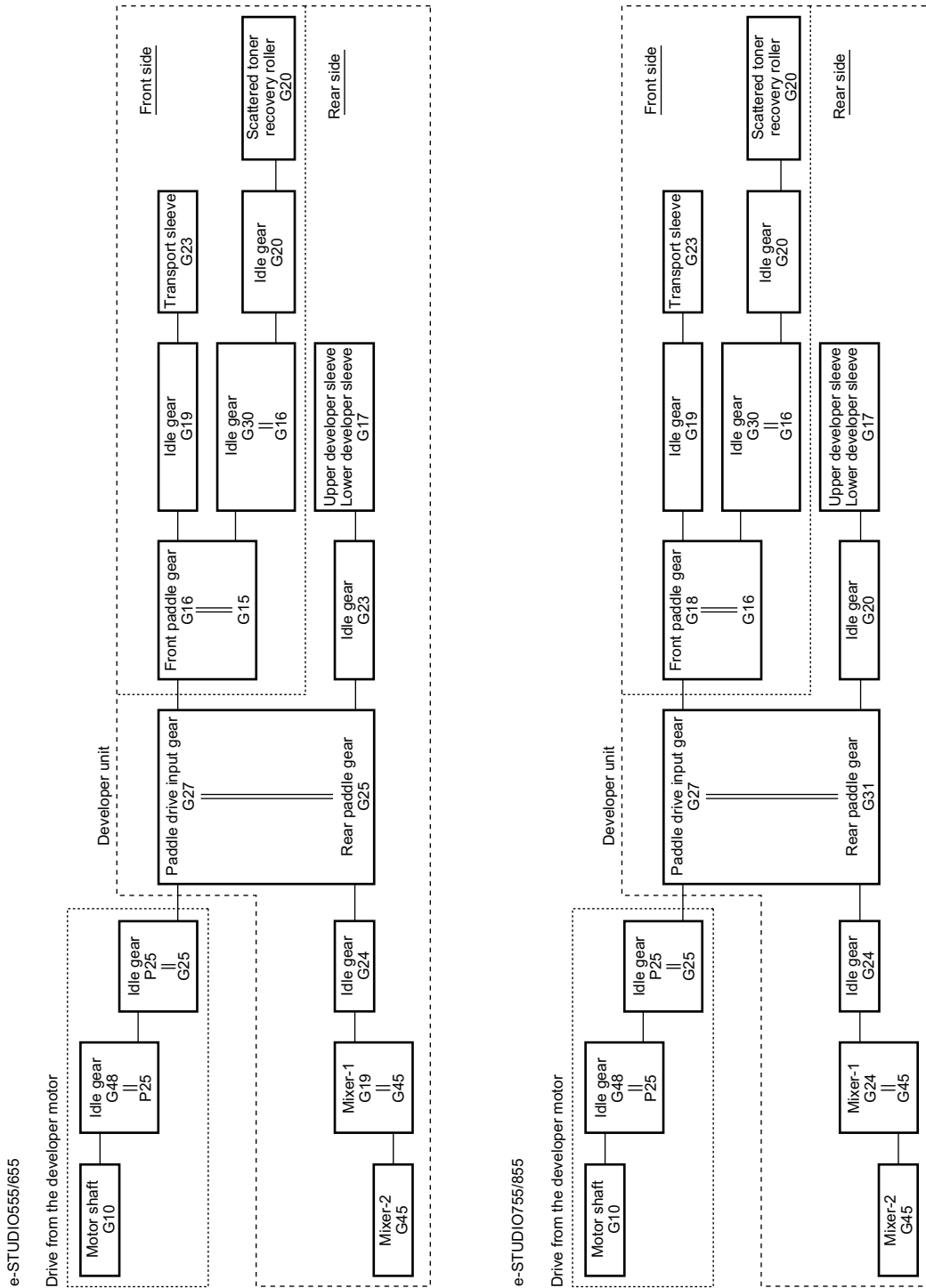

Fig. 11-4

11.4 Motor Control Circuit

11.4.1 New toner supply motor control circuit

The new toner supply motor, which is a DC motor driven by control signals from the main-CPU on the LGC board, rotates the toner cartridge.

This motor is driven when the on/off signal (TNMTON-0) output from the main-CPU moves to a high level. The motor rotation direction switching signal (TNMTCW-0) switches the rotational direction of this motor.

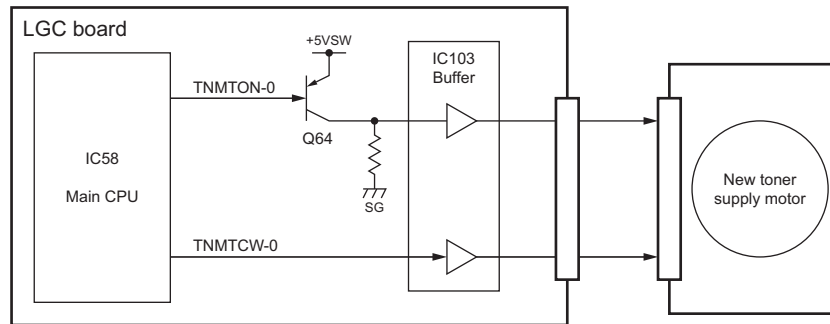

Fig. 11-5

Driving signal of new toner supply motor
(L: Low level, H: High level)

Signal		Motor Status
TNMTON-0	TNMTCW-0	
L	-	Off
H	L	Reverse rotation (detecting cartridge installation)
H	H	Forward rotation (when supplying toner)

11.4.2 Developer unit motor control circuit

The developer unit motor, which is a DC motor driven by control signals from the ASIC on the LGC board, drives the developer unit.

A driving PC board is embedded in this motor to perform the following controls.

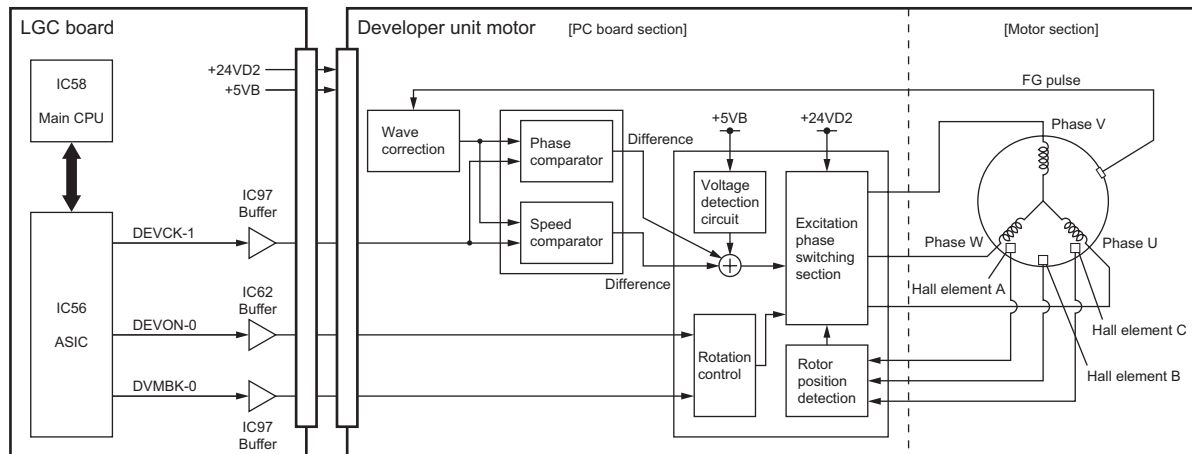

Fig. 11-6

1. ASIC outputs the control signals for the developer unit motor rotation.
(DEVON signal: Motor rotation command)
2. The excitation phase switching section excites each phase of the developer unit motor.
→ The developer unit motor is rotated.
3. Hall elements A, B and C detect the rotation position of the motor (rotor).
4. The excitation phase switching section switches the excitation of each phase.
(The motor keeps rotating by repeating from 2 to 4.)
5. An FG (Frequency Generator) pulse is generated by the rotation of the motor.
6. The FG pulse and the reference frequency (DEVCK-1) from the ASIC are compared in terms of the phase and speed, and the difference is added to the excitation phase switching section.
Fluctuations in the power supply voltage are also added to the value. (Signal generation)
7. According to the result of step 6), the switching timing of the excitation phase switching section is changed, namely, the FG pulse and the reference clock are controlled to be equal.
→ The developer unit motor rotates at a constant speed. (Lock range)
8. When the DVMBK signal from the ASIC moves to a low level, the developer unit motor is braked.
When the DEVON signal moves to a high level, the motor is stopped.

Control signal of developer unit motor

- DEVON signal:
This signal switches the on/off of the developer unit motor. When this signal moves to a low level, the motor is rotated, and when this moves to a high level, the motor is stopped.
- DEVCK signal:
This signal is a reference clock which keeps the developer unit motor rotation at a constant speed. When the cyclic change of the FG pulse period against this reference signal is within $\pm 6.25\%$, this is defined as a lock range (= the normal rotation of the motor). When the cyclic change is within this range, the LED on the driving PC board of this motor is lit.
- DVMBK signal:
This signal applies a brake on the developer unit motor. When this signal moves to a low level, a brake is applied to the rotation of the motor.

11.5 Auto-toner Circuit

11.5.1 General description

1. Function of the auto-toner circuit
 - Detects the toner density in the developer material, and supplies toner when the density is lowered to a certain level.
 - Detects that there is no toner left in the developer unit.

2. Configuration of the auto-toner circuit

- Auto-toner sensor:
Detects the toner density.
- Toner cartridge empty sensor:
Detects that the new toner is almost consumed. (The toner cartridge is empty.)
- Control section:
Controls each section to maintain the toner density of the developer material at a constant ratio.
- Control panel:
Displays a status that the toner cartridge is nearly empty.
- New toner supply section:
The new toner supply motor and the new toner transport motor in this section supply the new toner to the developer unit from the toner cartridge.
- Recycle toner supply section:
The hopper motor in this section supplies the recycle toner to the developer unit from the recycle toner hopper.

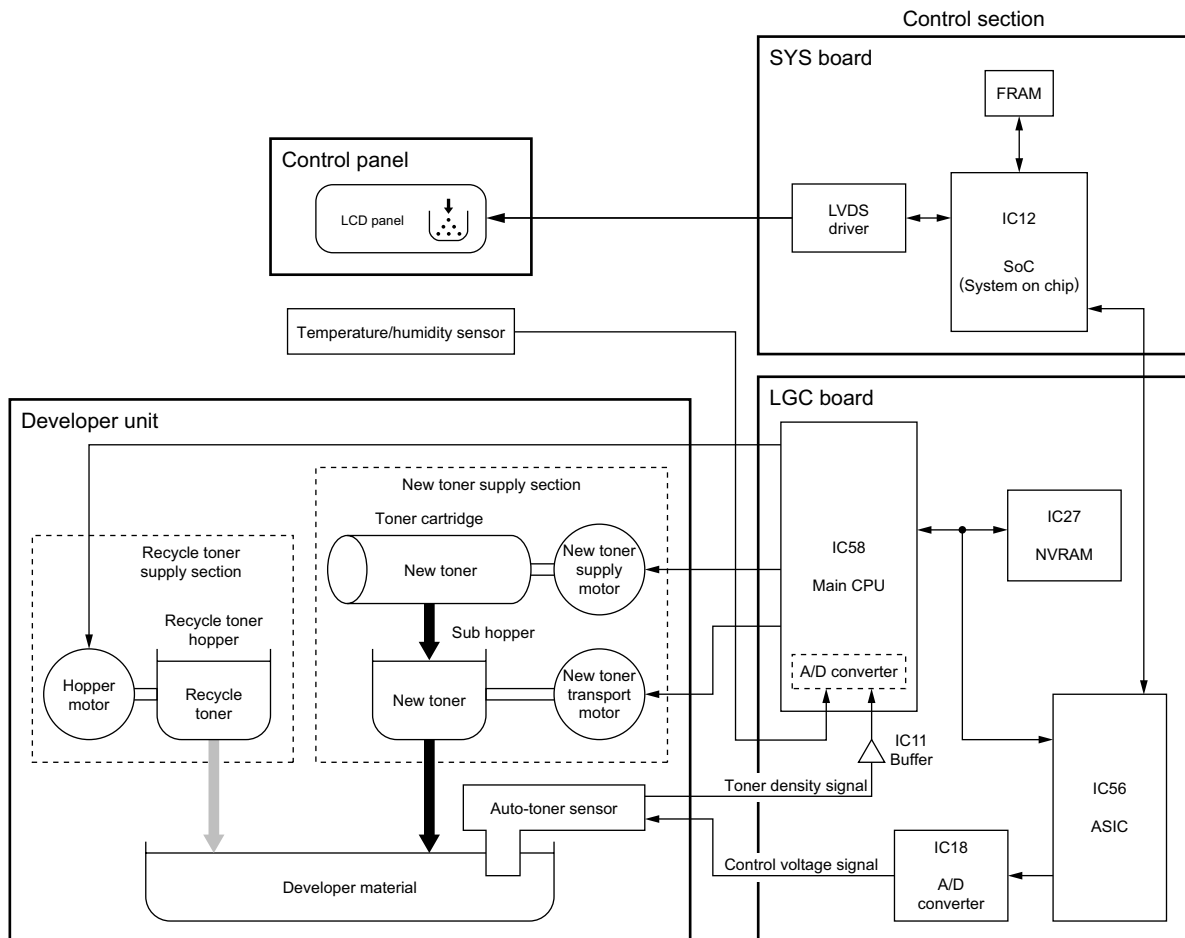

Fig. 11-7

11.5.2 Operation of auto-toner sensor

1. Functions of the auto-toner sensor

- Initializing function: When the copier is set up or when the developer material is replaced
The automatic adjustment is made so that the output of the auto-toner sensor (input value of the main-CPU) will be 2.45 to 2.85V for the toner density of new developer material.
- Toner density stabilizing function: During the printing operation
Through the following phases, the toner density is kept constant.
The toner is consumed.
 - The toner density is lowered.
 - The output change of the auto-toner sensor caused by humidity is detected.
 - The new toner transport motor, new toner supply motor and hopper motor are driven.
(The new toner supply motor and the hopper motor are driven only when the new toner is left in the toner cartridge and also the front cover (upper) is closed.)
 - The toner is supplied to the developer unit from the sub-hopper (toner cartridge) and the recycle toner hopper.
- Detection and release of empty status of the developer unit
The empty status of the developer unit is detected in the following procedure.
The new toner supply motor and the new toner transport motor are driven.
 - The output value of the auto-toner sensor remains the same.
 - The toner density is not changed.
 - The developer unit is judged as empty.

The empty status of the developer unit is released in the following procedure.
The new toner supply motor and the new toner transport motor are driven.

- The new toner is supplied to the developer unit from the toner cartridge.
- The output value of the auto-toner sensor is changed.
- The toner density returns to its normal value.
- The empty status of the developer unit is released.

2. Auto-toner sensor drive circuit

The auto-toner sensor is composed of the following circuits.

- Drive winding:
Magnetic head (primary side) with a high-frequency magnetic field, which forms a magnetic circuit in the developer material
- Detection winding:
Receiving the changes in the magnetic resistance of the developer material via a magnetic circuit (secondary side)
- DC conversion circuit:
Converting the high-frequency output from the detection winding to a DC signal (auto-toner output ATS-1A)

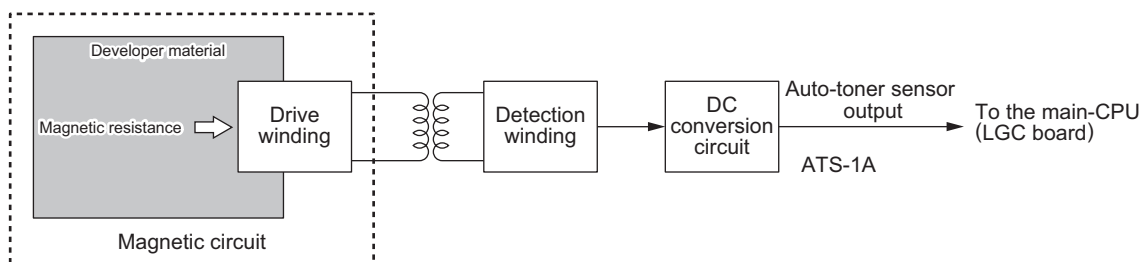

Fig. 11-8

- When the toner density is low:
 Toner ratio to the carrier in the developer material decreased
 → Magnetic resistance decreased
 → Detection output increased
 → Auto-toner output ATS-1A increased

- When the toner density is high:
 Toner ratio to the carrier in the developer material increased
 → Magnetic resistance increased
 → Detection output decreased
 → Auto-toner output ATS-1A decreased

11.6 Disassembly and Replacement

[A] Toner cartridge drive unit

[A-1] Toner cartridge drive unit

- (1) Take off the right front inner cover.
 (📖 P.2-41 "[B] Front right inner cover")
- (2) Disconnect 1 connector.
- (3) Loosen 1 screw to take off the bracket.
- (4) Pull down the fixing pin and rotate it by 90°.

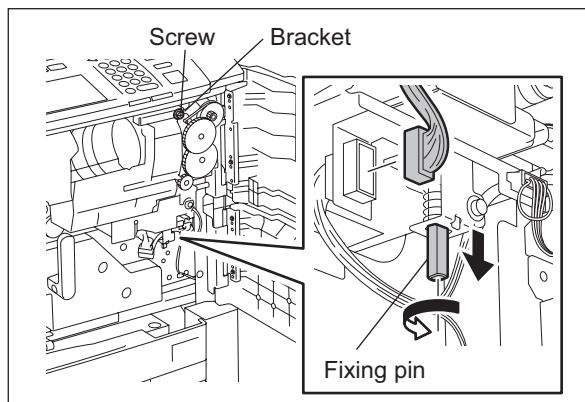

Fig. 11-9

- (5) Pull out the toner cartridge drive unit up to approx. 30°, and then take it off in the direction of the arrow.

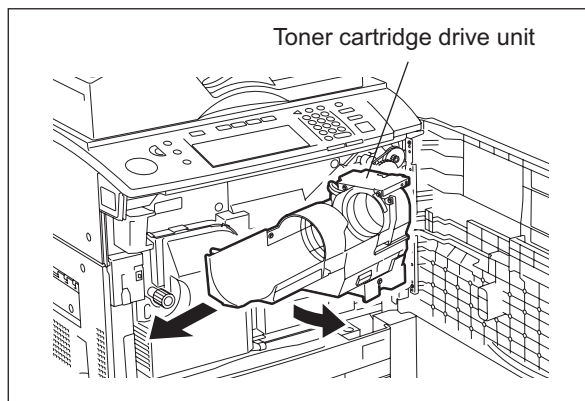

Fig. 11-10

[A-2] Toner cartridge switch (SW2)

- (1) Disconnect 2 connectors, remove 1 screw, and then take off the toner cartridge switch with the bracket.
- (2) Remove 2 screws to take off the toner cartridge switch.

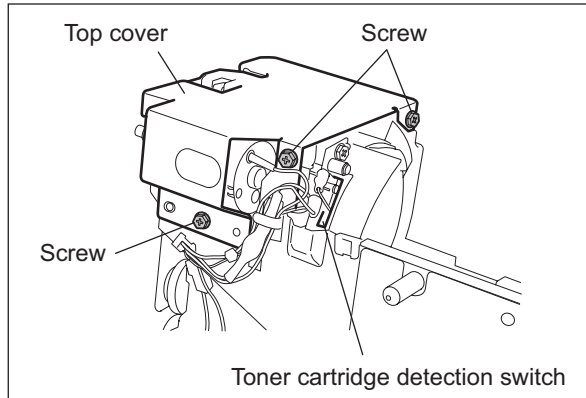

Fig. 11-11

[A-3] New toner supply motor (M5)

- (1) Remove 3 screws to take off the top cover.
- (2) Disconnect 1 connector, remove 2 screws, and then take off the new toner supply motor.

Note:

Pay attention to the size (length) of the screws. If incorrect ones are used, the motor could be damaged.

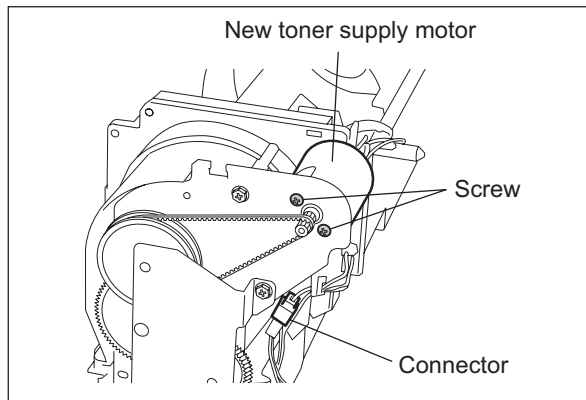

Fig. 11-12

[A-4] Toner cartridge empty sensor (S10)

- (1) Remove 2 screws, and then take off the toner cartridge empty sensor with the harness.
- (2) Disconnect 1 connector from the toner cartridge empty sensor.

Note:

Be careful not to damage the sensor when connecting and disconnecting the connector.

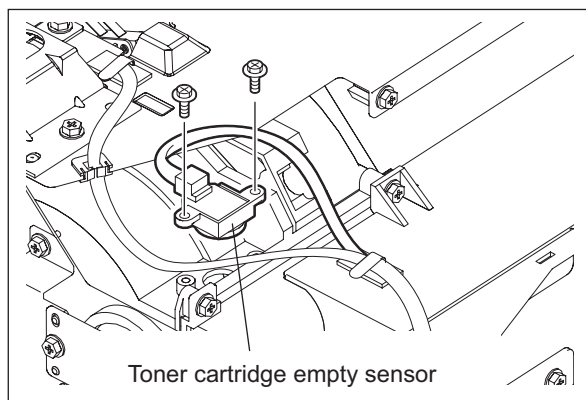

Fig. 11-13

[A-5] New toner transport motor (M6)

- (1) Remove 3 screws to take off the top cover.

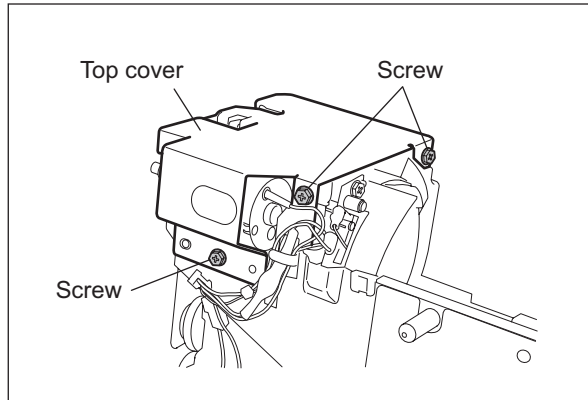

Fig. 11-14

- (2) Disconnect 1 connector to release the harness from the clamp.

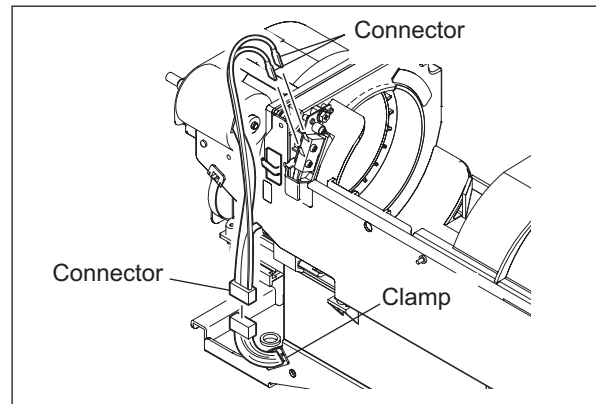

Fig. 11-15

- (3) Remove 2 screws to take off the inner cover.
(4) Remove 1 screw.
(5) Remove 3 screws to take off the toner drive section.

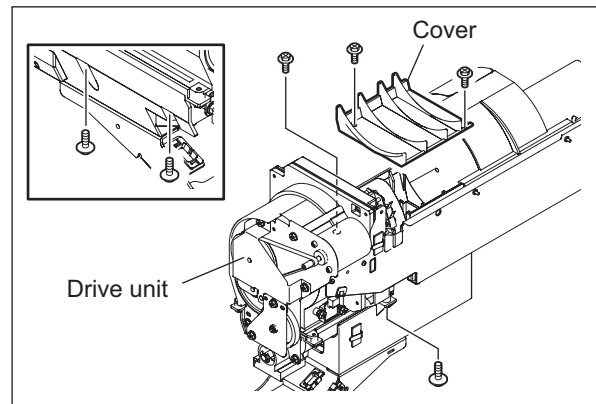

Fig. 11-16

- (6) Disconnect 1 connector to release the harness from the clamp.
- (7) Remove 2 screws to take off the motor with bracket.

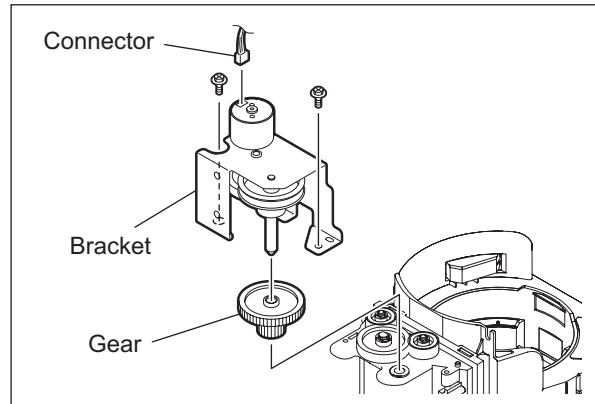

Fig. 11-17

- (8) Remove 2 E-rings and then 2 gears.
- (9) Remove 2 screws to take off the new toner transport motor.

Note:

Pay attention to the size (length) of the screws. If incorrect ones are used, the motor could be damaged.

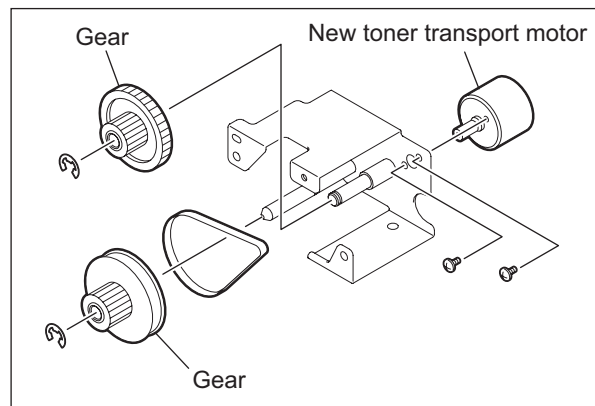

Fig. 11-18

[B] Toner recycle unit

[B-1] Toner recycle unit

- (1) Take off the toner cartridge drive unit.
(📖 P.11-12 "[A] Toner cartridge drive unit")
- (2) Remove 2 screws to take off the left inner cover.
- (3) Disconnect 1 connector, remove 2 screws, and then take off the toner recycle unit.

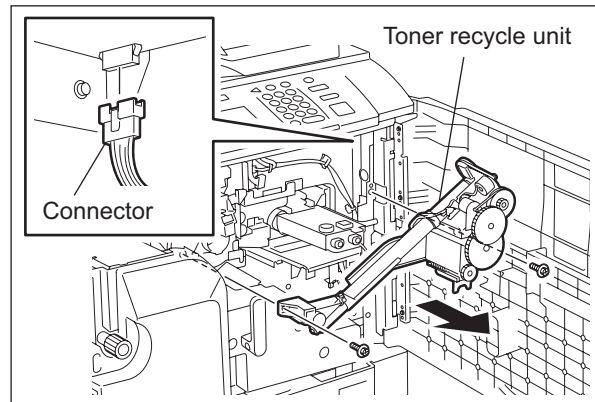

Fig. 11-19

Notes:

1. Be extremely careful when handling this unit because toner may spill out from the joint with the toner recycle unit, cleaner unit and developer unit.
2. Install the window of the shutter section on the toner recycle unit so that it matches with the protrusion of the developer unit.
3. Be careful to allow as little vibration as possible to the unit when installing and removing the toner recycle unit. Vibration could cause stains on the image after assembling, especially when the remaining toner amount in the cartridge is small.

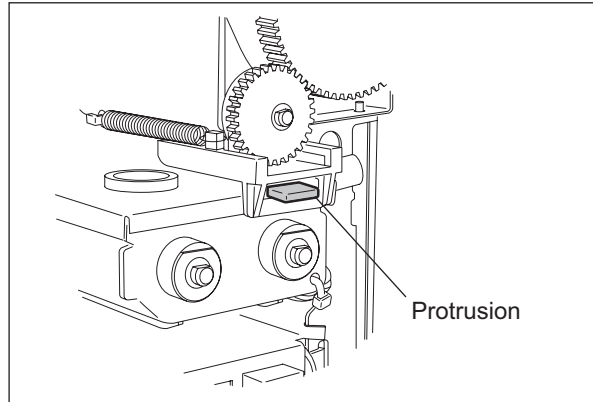

Fig. 11-20

[B-2] Recycle toner transport motor (M8) and Hopper motor (M7)

- (1) Disconnect 1 connector, remove 2 screws, and then take off the recycle toner transport motor.
- (2) Disconnect 1 connector, remove 2 screws, and then take off the hopper motor.

Note:

Pay attention to the size (length) of the screws. If incorrect ones are used, the motor could be damaged.

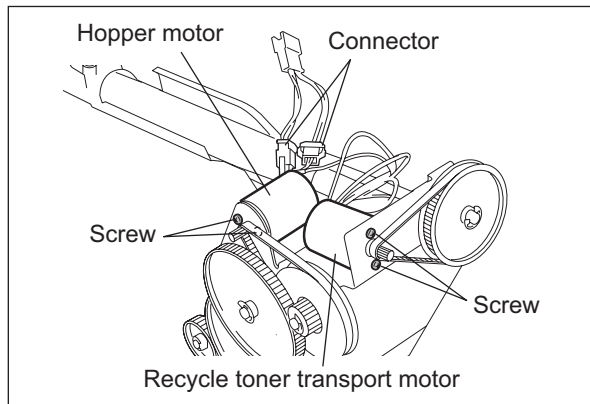

Fig. 11-21

[C] Developer unit

- (1) Take off the toner recycle unit. (P.11-15 "[B] Toner recycle unit")
- (2) Rotate the L-shaped shaft upward to release the lock.
- (3) Disconnect 1 connector and pull out the developer unit to the front side.

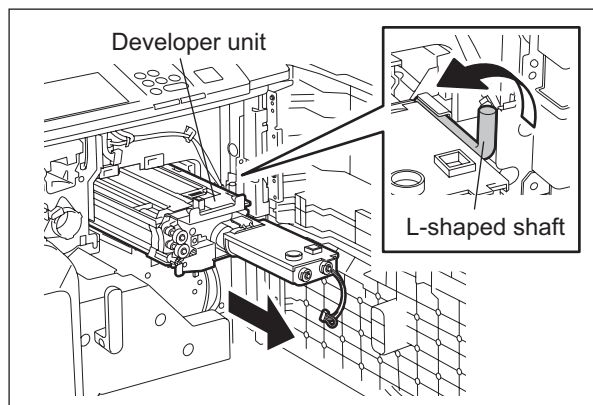



Fig. 11-22

[D] Developer material

- (1) Take off the developer unit.
( P.11-16 "[C] Developer unit")
- (2) Remove 2 screws to take off the top cover.

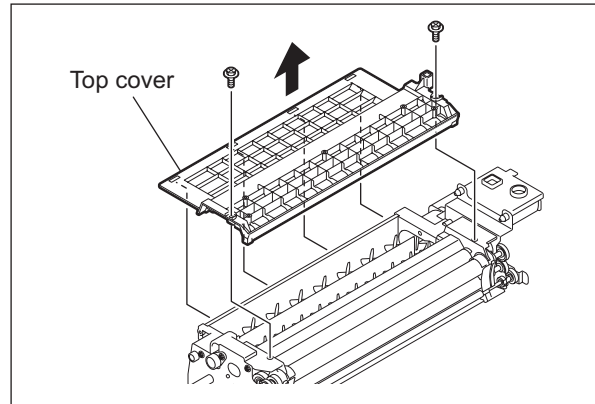

Fig. 11-23

- (3) Tilt the developer unit and take out the old developer material by rotating the gear on the rear side.

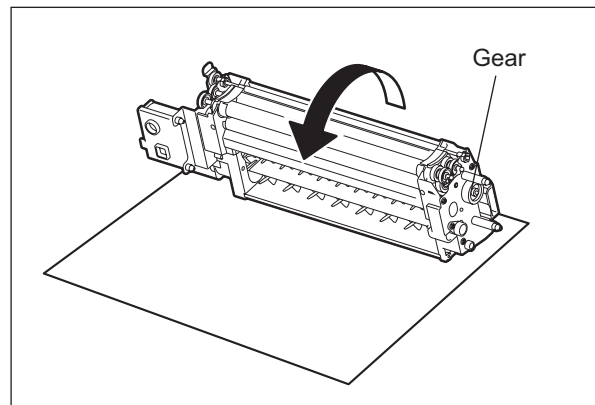

Fig. 11-24

- (4) Put in the new developer material.
- (5) Rotate the gear on the rear side several times so that the developer material is mixed evenly.

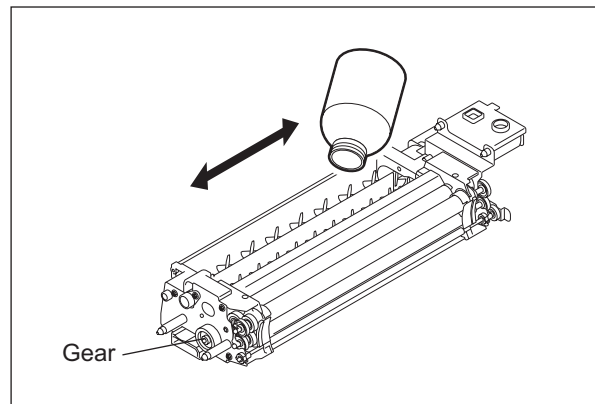

Fig. 11-25

Note:

When installing the top cover, make sure that the latches insert completely, the cover does not catch in the urethane seal and the urethane sheets are overlapped correctly.

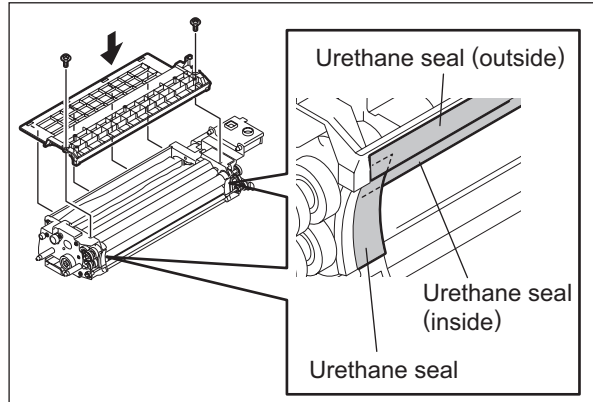



Fig. 11-26

[E] Doctor blade

- (1) Take out the developer material.
( P.11-17 "[D] Developer material")
- (2) Remove 2 screws and take off the doctor blade.

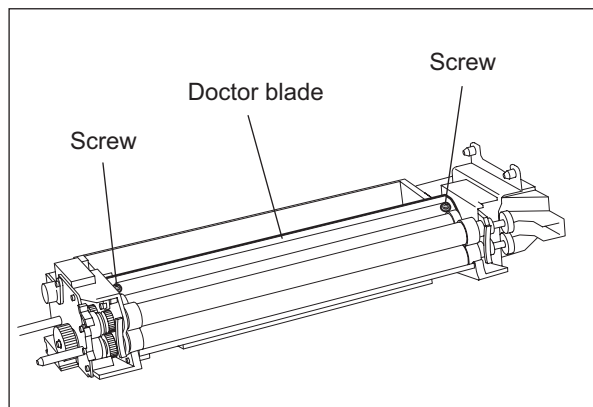

Fig. 11-27

Note:

When installing the doctor blade, butt both edges to the protrusion on the front and rear side frame and tighten the screw. (The doctor sleeve gap does not need to be adjusted.)

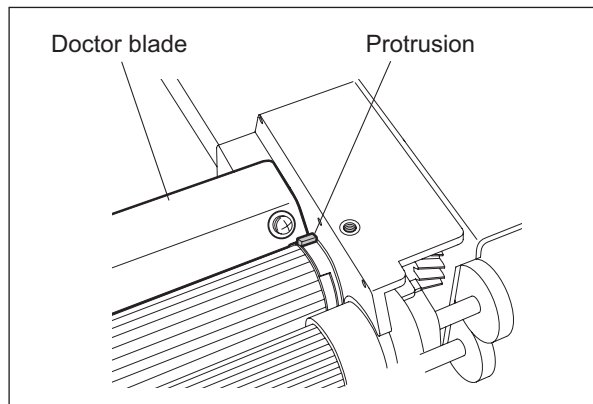



Fig. 11-28

[F] Auto-toner sensor (S12)

- (1) Take out the developer material.
( P.11-17 "[D] Developer material")
- (2) Release the harness from the clamp and pull out the harness.
- (3) Remove 2 screws to take off the auto-toner sensor.

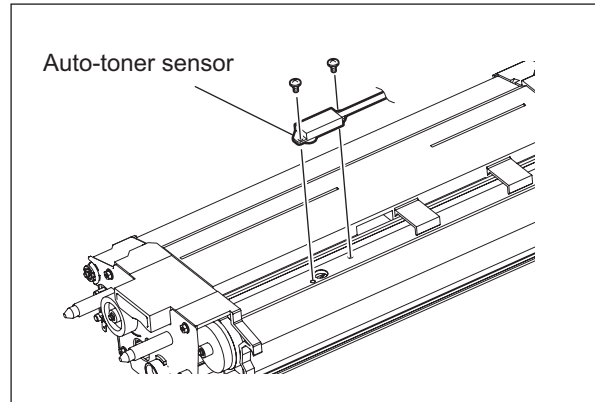



Fig. 11-29

[G] Guide roller

[G-1] Guide roller on the front side

- (1) Take off the developer unit.
( P.11-16 "[C] Developer unit")
- (2) Remove 2 screws, take off the bracket and then remove 3 gears.

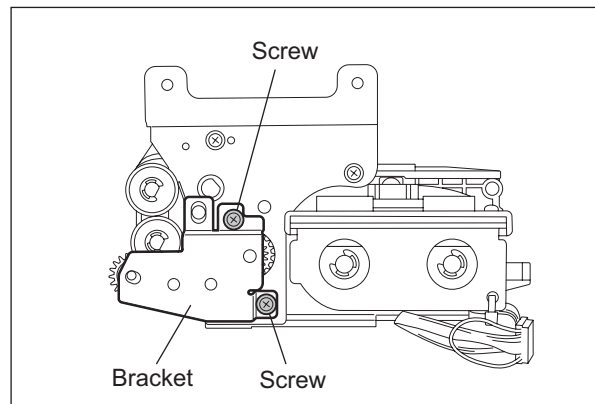

Fig. 11-30

- (3) Remove 1 E-ring and then the spring.
- (4) Remove 2 E-rings and take off 2 guide rollers.

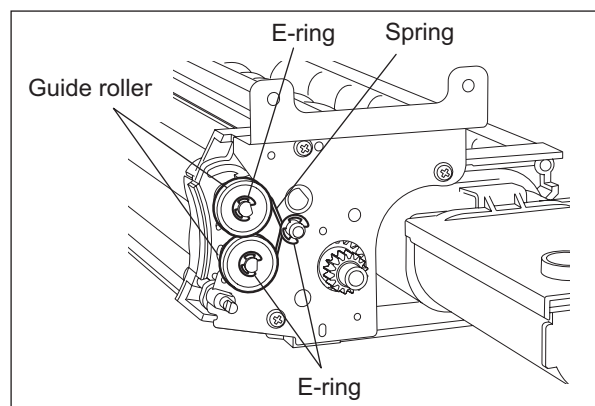

Fig. 11-31

[G-2] Guide roller on the rear side

- (1) Take off the developer unit.
(P.11-16 "[C] Developer unit")
- (2) Remove 1 E-ring and then the gear.
- (3) Remove 1 E-ring, 1 spring and then the bushing.
- (4) Remove 4 screws, the rear side frame and then disconnect the bias connector.

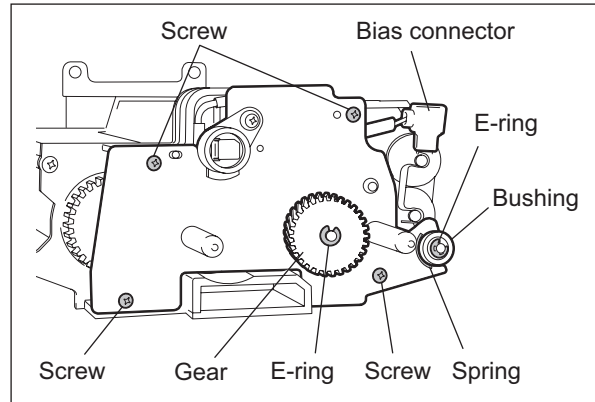

Fig. 11-32

- (5) Remove the bias plate and the spring.
- (6) Remove 2 E-rings and take off 2 guide rollers.

Note:

Make sure that the color of the guide roller is correct when assembling. (upper side: white, lower side: black)

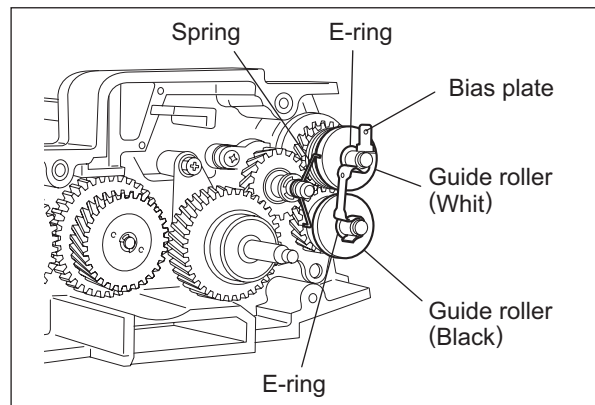

Fig. 11-33

[H] Scattered toner recovery roller / Developer sleeves (Magnetic roller)

- (1) Take off the guide roller.
(P.11-19 "[G] Guide roller")
- (2) Remove 3 screws to take off the front side plate.

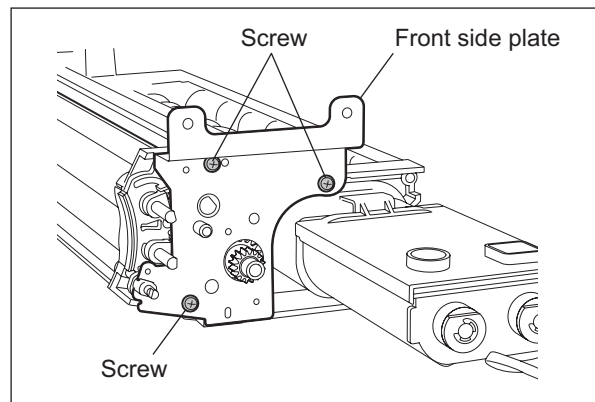

Fig. 11-34

- (3) Take off the toner recovery roller.
- (4) Remove 2 screws of the developer sleeve holder on the front side.

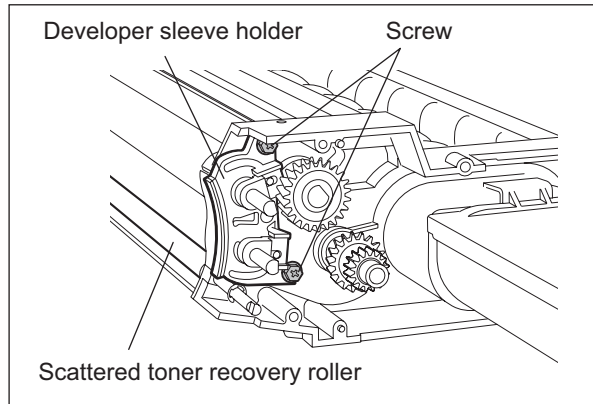

Fig. 11-35

- (5) Remove the bearing, the E-ring, and then the gear and the parallel pin.
- (6) Remove 2 screws of the developer sleeve holder on the rear side.
- (7) Take off the upper and lower developer sleeve with the holder.

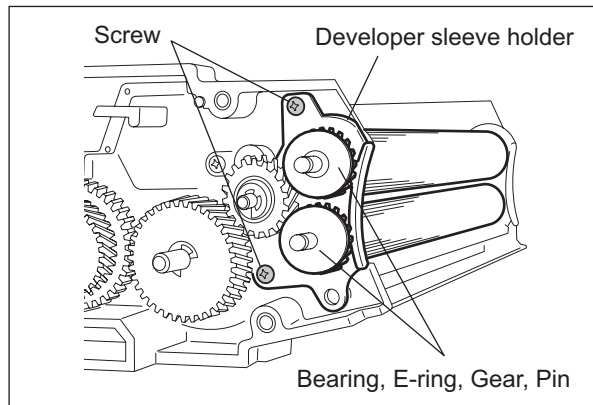

Fig. 11-36

- (8) Remove 2 pole position fixing bushings, and then 2 E-rings.
- (9) Remove 4 E-rings and then 2 gears.

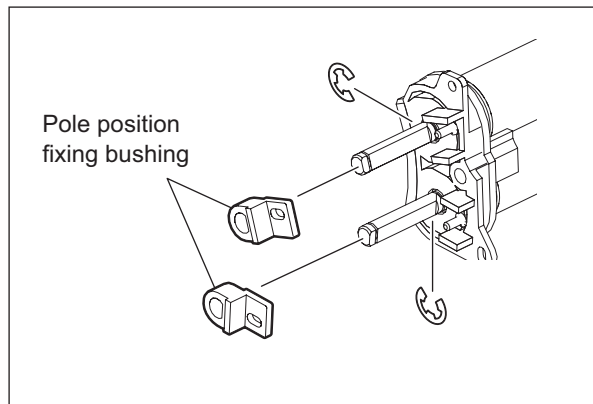

Fig. 11-37

- (10) Remove the developer sleeve holder on the front and rear side.

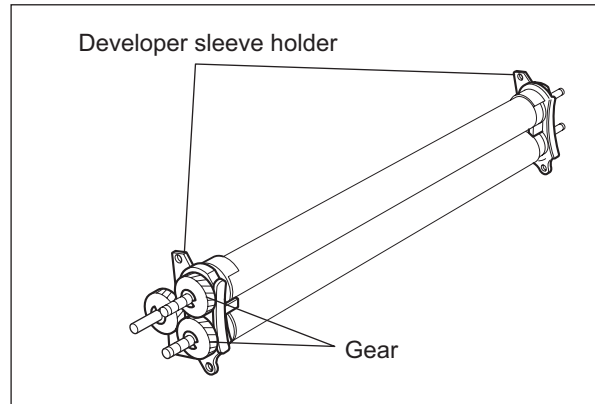

Fig. 11-38

- (11) Remove 2 seals, 4 shield bushings, the scraper, and then take off the upper and lower developer sleeves.
 (12) Replace the oil seal pressed into 2 shield bushings on the rear side, if necessary.
 * Procedure for replacing an oil seal:
 (P.11-25 "Fig. 11-47 ")

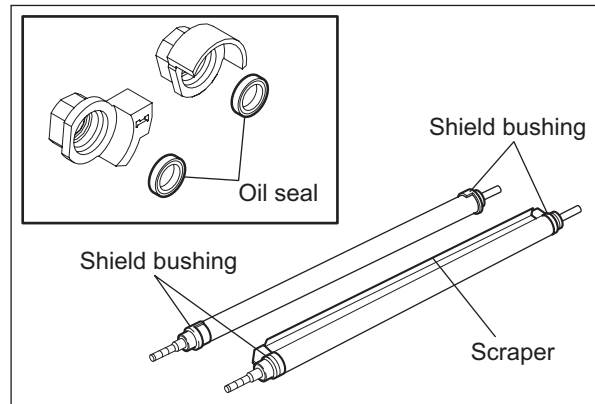

Fig. 11-39

[I] Transport sleeve

- (1) Remove 1 screw and then the pole position fixing bushing on the rear side.

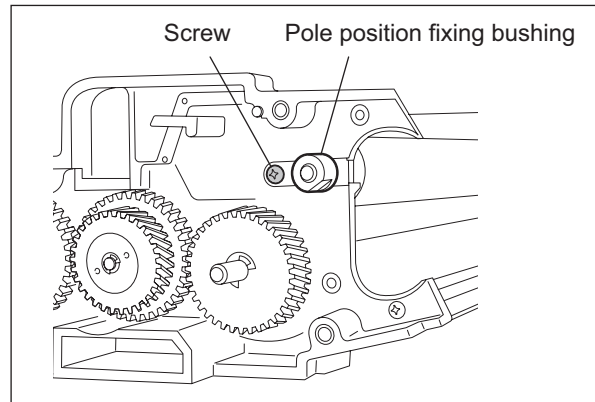

Fig. 11-40

- (2) Remove the gear, E-ring and bearing on the front side, and then take off the transport sleeve.
 - (3) Replace 1 oil seal pressed into the front side of the frame, if necessary.
- * Procedure for replacing an oil seal:
 (📖 P.11-25 "Fig. 11-47 ")

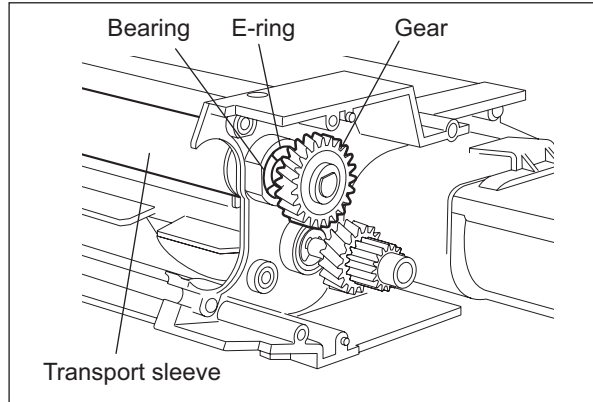

Fig. 11-41

[J] Mixer

- (1) Take off the auto-toner sensor.
 (📖 P.11-19 "[F] Auto-toner sensor (S12)")
- (2) Remove 2 E-rings and then 2 gears on the rear side.
- (3) Remove 2 bearings and replace 2 oil seals pressed into the frame, if necessary.

Note:

Apply grease (Alvania No. 2) all around the mixer shaft before installing the bearings.

- (4) Take off the cover.

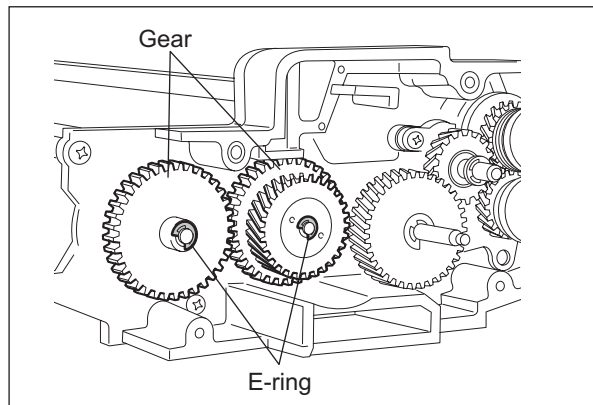

Fig. 11-42

- (5) Remove 2 E-rings, 2 screws and then take off the mixer nozzle on the front side.
 - (6) Pull out 2 mixers.
 - (7) Replace the oil seal pressed into the mixer nozzle, if necessary.
- * Procedure for replacing an oil seal:
 (📖 P.11-25 "Fig. 11-47 ")

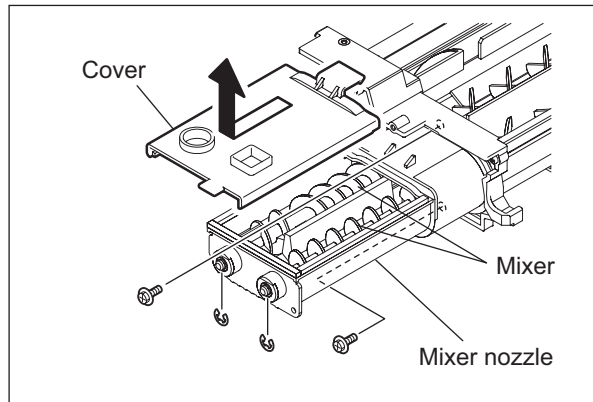

Fig. 11-43

[K] Paddle

- (1) Take off the mixer. (📖 P.11-23 "[J] Mixer")
- (2) Remove 1 E-ring, the gear and parallel pin on the rear side.

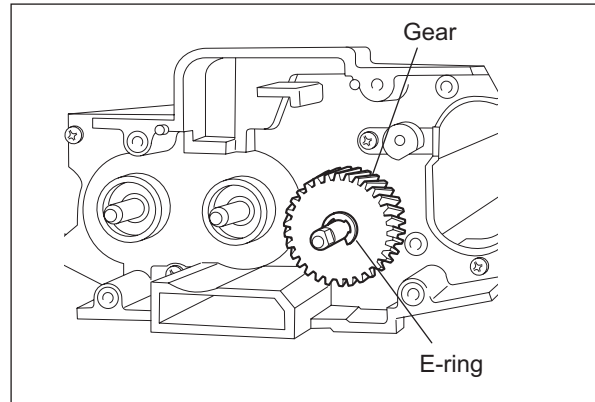

Fig. 11-44

- (3) Remove 1 screw, 1 E-ring and then the paddle bushing on the rear side.
- (4) Replace the oil seal pressed into the paddle bushing, if necessary.

* Procedure for replacing an oil seal:
(📖 P.11-25 "Fig. 11-47 ")

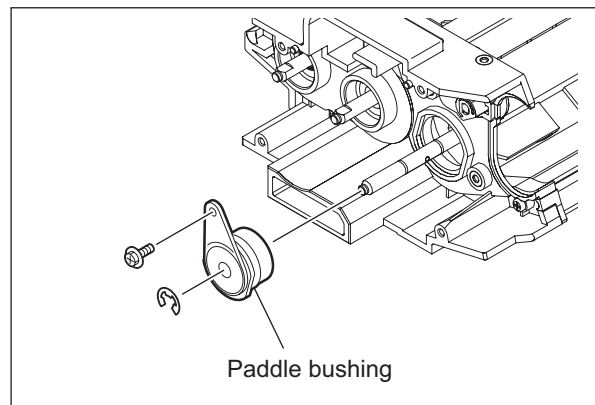

Fig. 11-45

- (5) Remove the gear, 1 E-ring and then paddle bushing on the front side.
- (6) Replace the oil seal pressed into the paddle bushing, if necessary.
- (7) Take out the paddle.

* Procedure for replacing an oil seal:
(📖 P.11-25 "Fig. 11-47 ")

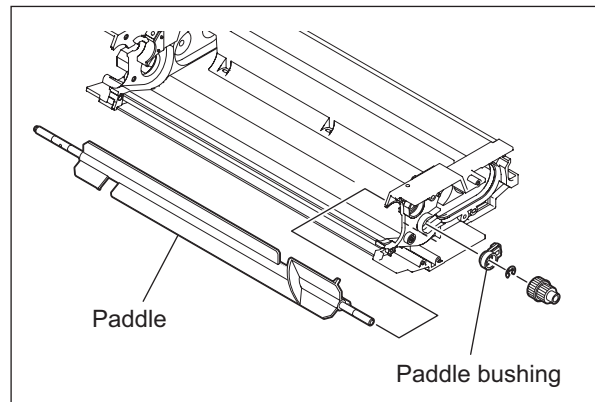

Fig. 11-46

<< Procedure for replacing an oil seal >>

In the developer unit, the oil seals are used at the following 9 places.

- Rear side of the upper and lower developer sleeve (1 for each)
- Front side of the transport sleeve (1)
- Rear and front side of the mixer (2 for each)
- Rear and front side of the paddle (1 for each)

Replace the oil seal according to the procedure below.

1. Insert the fine screwdriver or the like into the inside of the oil seal, and then take out the oil seal by hooking it out.
2. Make sure of the direction of the new oil seal and push it in parallel to the frame, bushing or the like. (See the figure on the right.)
3. Apply the grease (Alvania No. 2; approx. 2 grains of rice) all around the inside diameter of the oil seal.

Note:

Wipe off the grease which has run off to the inner side of the oil seal.

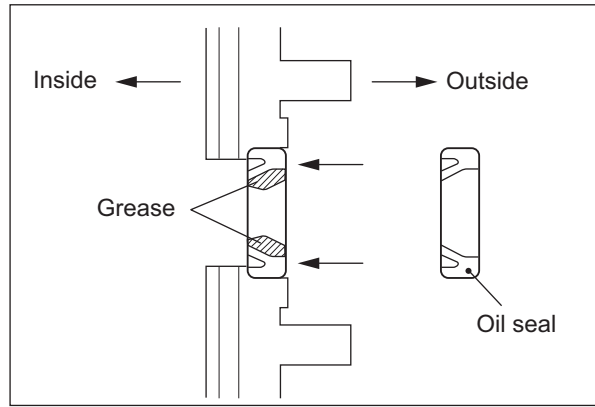

Fig. 11-47

[L] Developer unit motor (M10)

- (1) Take off the rear cover.
(P.2-45 "[L] Rear cover")
- (2) Take off the SYS board case.
(SERVICE HANDBOOK "5.3.1 Installation and Separation of PC Boards / HDD: [A] System control PC board (SYS board) / System interface PC board (SYSIF board) / SYS board case")
- (3) Remove 3 screws to take off the flywheel.
- (4) Disconnect 1 connector, remove 3 screws and then take off the developer unit motor with bracket.
- (5) Remove 2 screws to take off the motor from the bracket.

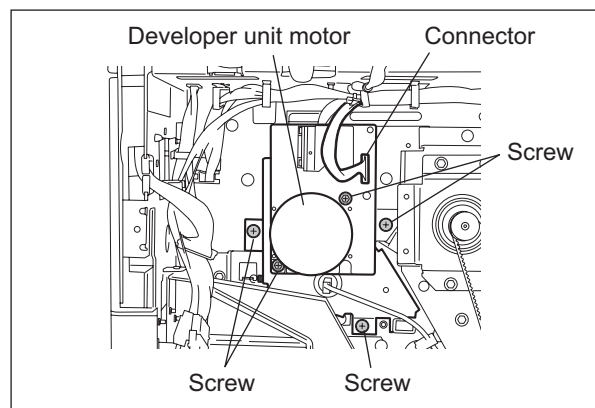

Fig. 11-48

[M] Developer unit detection switch (SW3)

- (1) Take off the cleaner unit.
(P.10-7 "[A] Cleaner unit")
- (2) Disconnect 1 connector, remove 1 screw and then take off the sensor bracket.

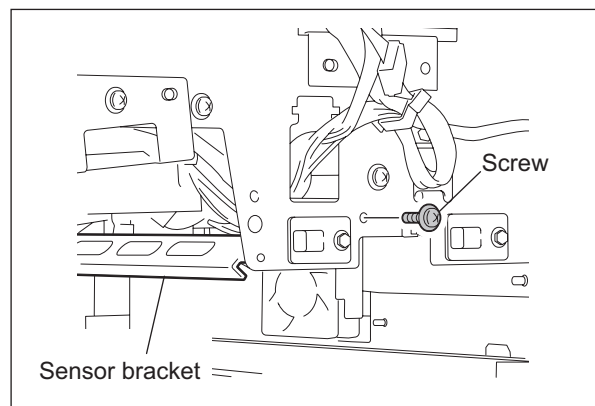

Fig. 11-49

- (3) Disconnect 2 connectors, remove 1 screw and then take off the developer unit detection switch.

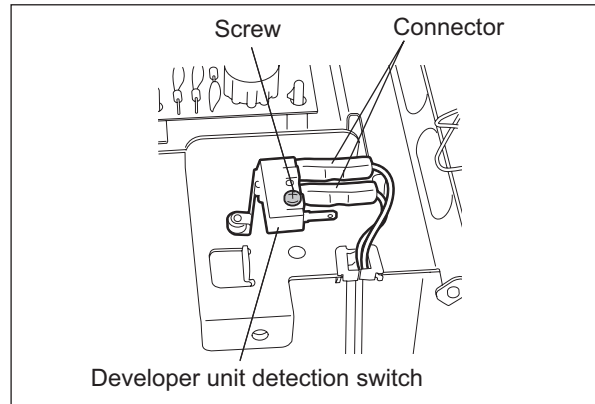

Fig. 11-50

[N] Toner filter unit / Developer unit fan (M31)

- (1) Take off the right rear cover.
(P.2-43 "[H] Right rear cover")
- (2) Pull out the toner filter.
- (3) Remove 2 screws to pull out the filter duct.
- (4) Disconnect 1 connector of the fan.

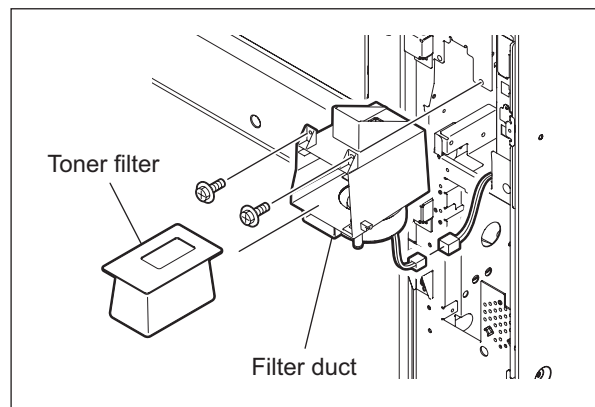

Fig. 11-51

- (5) Remove 3 screws to take off the fan.

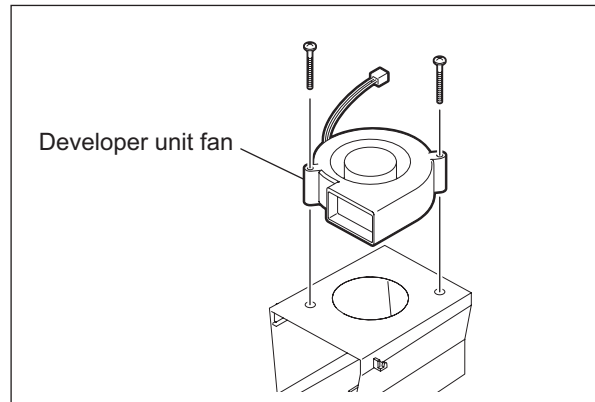

Fig. 11-52

[O] Toner bag full detection sensor (S11)

- (1) Take off the SYS board case.
(SERVICE HANDBOOK "5.3.1 Installation and Separation of PC Boards / HDD: [A] System control PC board (SYS board) / System interface PC board (SYSIF board) / SYS board case")
- (2) Disconnect 1 connector and remove 1 screw to take off the toner bag full detection sensor.

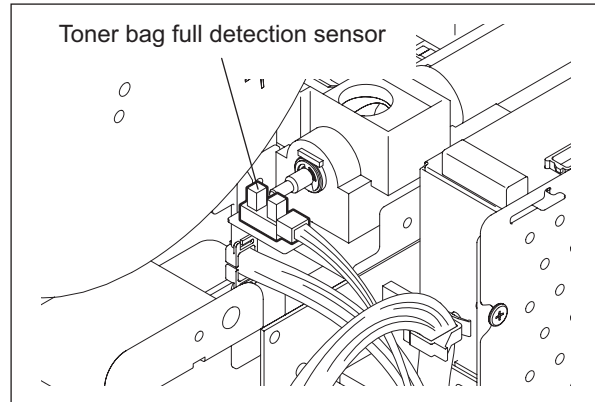

Fig. 11-53

[P] Used toner transport motor (M9)

- (1) Take off the rear cover
(P.2-45 "[L] Rear cover")
- (2) Take off the left rear cover
(P.2-44 "[K] Left rear cover")
- (3) Disconnect 1 connector and remove 2 screws to take off the used toner transport motor.

Note:

Pay attention to the size (length) of the screws. If incorrect ones are used, the motor could be damaged.

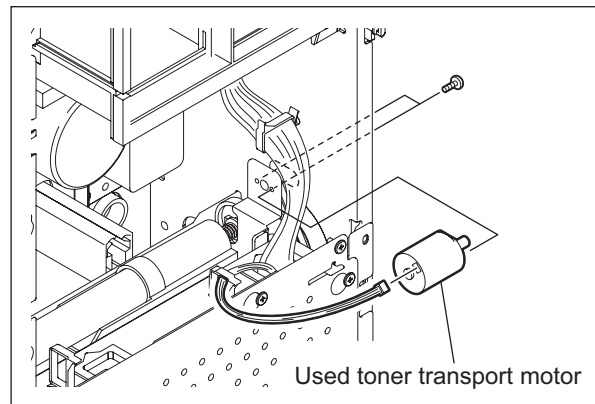

Fig. 11-54

12. TRANSFER/TRANSPORT UNIT

12.1 General Description

The transfer/transport unit consists of the following 3 sections.

- Transfer section: Separates the paper from the drum with the transfer belt, and transports the paper to the fuser unit.
- Fuser unit: Fuses the toner onto the paper.
- Horizontal transport section: Transports the reversed paper to the intermediate transport roller during duplex printing.

The general descriptions of the transfer section and the horizontal transport section are shown below. (The general description of the fuser unit is written in Chapter 13.)

Transfer section:

The paper transported from the registration roller and the toner on the drum are transferred to the transfer belt by a static attraction (the paper is separated from the drum here), and then the separated paper is transported to the fuser unit. The toner adhered on the transfer belt is cleaned in the belt cleaning mechanism, and then transported to the used toner bag. The transfer section is driven by the transfer belt motor (M14).

Horizontal transport section:

The reversed paper for duplex printing is transported to the horizontal transport section. At the horizontal transport section, the paper is transported to the intermediate transport roller. The section includes 4 transport rollers controlled by 3 clutches (CLT1/2/3). The fuser motor (M3) drives the operation of this section.

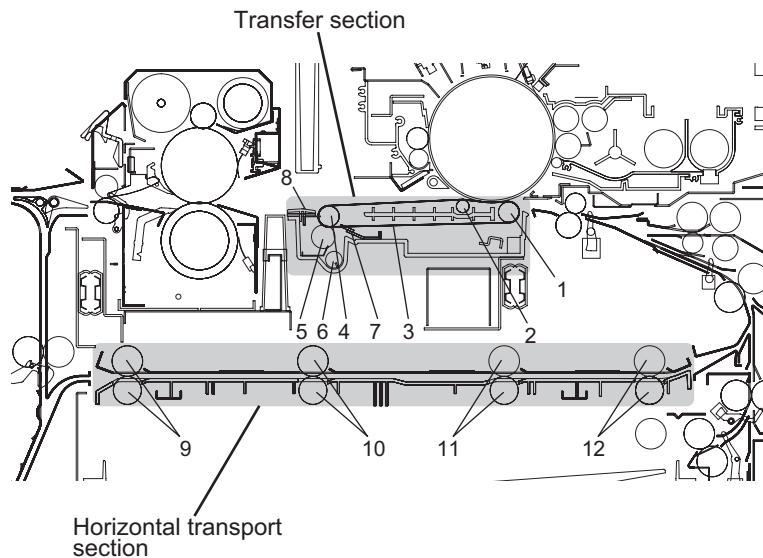

Fig. 12-1

No.	Name	No.	Name
1	Follower roller	7	Cleaning blade
2	Power supply roller	8	Transport guide
3	Transfer belt	9	Horizontal transport roller-1
4	Transfer belt drive roller	10	Horizontal transport roller-2
5	Cleaning brush	11	Horizontal transport roller-3
6	Recovery auger	12	Horizontal transport roller-4

12.2 Functions

(1) Transfer belt unit

The transfer belt unit is a main unit of the transfer section. This unit is divided into 2 parts; the belt support/power supply section which supports and rotates the belt and supplies the power to the belt, and the cleaning mechanism section which scrapes off the toner adhered on the belt surface.

The transfer belt motor (M14) drives the transfer belt unit.

The drive from the transfer belt motor (M14) is transmitted to the drive gear and drive roller through the timing belt and relay gears. The drive is transmitted to the transfer/transport unit with a gear having a planetary joint.

(2) Transfer belt support/power supply section

The transfer belt is supported by 3 rollers; transfer belt drive roller, follower roller and power supply roller. A voltage, whose polarity is reverse to that of the toner on the photoconductive drum, is applied on the power supply roller. The current flowing to the transfer belt is controlled at a constant current of 70 μA (85 μA : e-STUDIO755/855). (The voltage is normally between +2 kV and +5 kV, while the applied voltage changes due to this constant-current control.) A voltage of +510 V is applied on the follower roller by a varistor. A high-voltage probe is required for this measurement. Do not use a digital voltmeter for your safety.

(3) Transfer belt

The transfer belt is a high-precision flat rubber belt with coating, holding electrical resistance, which electrostatically attracts the paper (toner).

(4) Transfer belt cleaning mechanism

The transfer belt cleaning mechanism section scrapes off the residual toner or paper dusts on the transfer belt surface with the transfer belt cleaning blade and transfer belt cleaning brush, and also transports the used toner with the recovery auger.

(5) Transfer belt cleaning blade

The cleaning blade removes paper dusts and foreign objects left on the transfer belt surface after the separation of the paper.

(6) Transfer belt cleaning brush

The cleaning brush is a conductive part to clean the toner electrostatically, and the voltage whose polarity is reverse to that of toner is applied on it. The current flowing to the cleaning brush is controlled at a constant current of 5 μA . (The voltage is normally between +100V and +500V, while the applied voltage changes due to this constant-current control.) A high-voltage probe is required for this measurement. Do not use a digital voltmeter for your safety.

(7) Recovery auger

The recovery auger transports the residual toner scraped off with the transfer belt cleaning blade and transfer belt cleaning brush to the used toner transport auger section.

(8) Transport guide

The transport guide leads the electrostatically attracted paper to the fuser unit. The guide is made of a material which prevents a frictional charge caused by the paper.

(9) Transfer/transport unit lock/unlock mechanism

The transfer/transport unit lock/release mechanism locks the unit in the equipment, and unlocks it to draw the unit out to the front side when the paper jam is being cleared. The mechanism also separates the transfer belt unit from the drum when the transfer/transport unit is drawn out. When the unit is being drawn out, the mechanism can prevent the erroneous operation of the handle. When the handle is turned clockwise (in a horizontal position), the unit can be drawn out. Insert the transfer/transport unit into the equipment and turn the handle counterclockwise (in a vertical position), so that the unit can be locked in. If the unit is not inserted completely, the handle cannot be turned from the horizontal position.

(10) Transfer belt unit contact/release mechanism

When printing is completed or a paper jam has occurred, the mechanism releases the transfer belt unit from the photoconductive drum. When printing is started, the mechanism contacts the unit with the photoconductive drum.

The cam is rotated by the drive of the transfer belt cam motor (M15). Along with this rotation, the lever on the rear side of the transfer/transport unit moves up and down, and thus the transfer belt unit and the drum are contacted or released.

The phase of the cam is controlled by the transfer belt release detection sensor (S15) and the transfer belt contact detection sensor (S16).

(11) Drum damp heater (DH3) (condensation prevention)

The drum damp heater (DH3) is installed under the transfer belt. The power is supplied to this heater when the main switch (SW6) is turned OFF.

(12) Horizontal transport section

The paper reversed for duplex printing is transported to the horizontal transport section. At this section, the paper is transported to the intermediate transport roller.

This section is driven by the fuser motor (M3) and controlled by the horizontal transport section driving clutches-1 (CLT1), -2 (CLT2) and -3 (CLT3), and this drive is transmitted to the transport roller. The horizontal transport sensors-1 (S19), -2 (S20) and -3 (S21) detect the paper transport.

12.3 General Description of Transfer Belt Unit Operation

1. The transfer belt unit is released from the photoconductive drum in the ready status.
2. The transfer belt is lifted, as well as rotated, and contacted with the photoconductive drum at the start of printing.
3. The voltage of the high-voltage transformer is applied on the transfer belt through the power supply roller.
4. Since the surface of the transfer belt is positively charged by a dielectric polarization, the belt electrostatically attracts the paper from the drum. Thus the processes of transfer, separation and paper transport are continuously performed.
5. The transfer belt unit is lowered, stops rotating, and waits at the released position from the photoconductive drum after the completion of printing.

12.4 Transfer belt motor control circuit

The transfer belt motor is a stepping motor driven by the control signal output from the main CPU on the LGC board and rotates the transfer belt.

The transfer belt motor is driven by the pulse signal (TRMA-0, TRMB-0, TRMAB-0, TRMBB-0) output from the motor driver. These pulse signals are formed based on the reference clock signal (TRMCK-0) and output only when the enable signal (TRMEN-1) is L level. Also, the rotational speed of the motor is switched by changing the frequency of the reference clock signal (TRMCK-0).

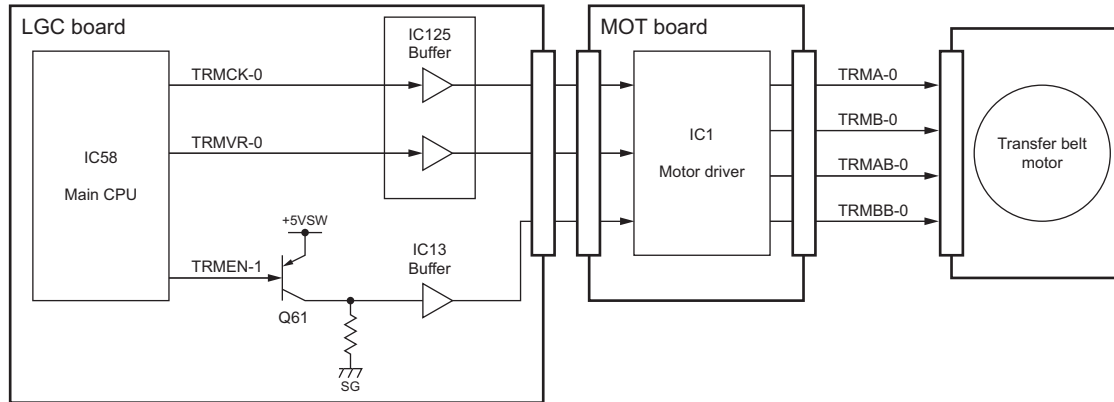

Fig. 12-2

Transfer belt motor drive signal

Signal			Motor status
TRMCK-0	TRMEN-1	TRMVR-0	
Pulse signal	L	L	Rotation when accelerating/ decelerating
	L	H	Rotation at a constant speed
-	H	-	Stop

12.5 Disassembly and Replacement

[A] Transfer unit

- (1) Open the front cover and take out the transfer/transport unit by turning the lever clockwise.

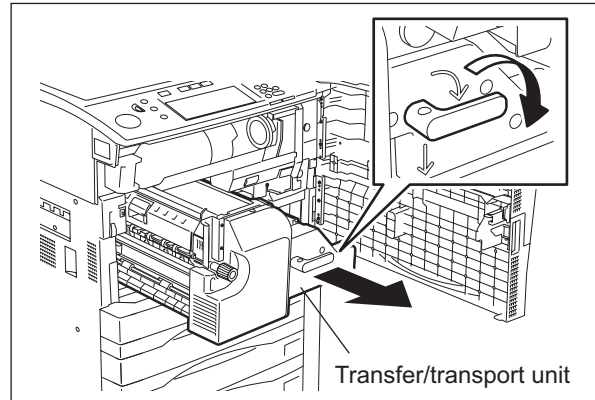

Fig. 12-3

- (2) Remove 1 screw to take off the handle.
- (3) Remove 2 screws to take off the cover.

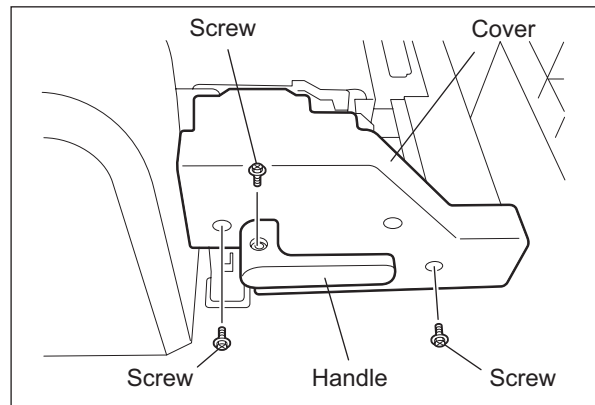

Fig. 12-4

- (4) Disconnect 2 connectors. (Raise the belt when disconnecting the connector on the right side.)
- (5) Remove 1 clip and slide the bearing on the front side to inside.
- (6) Remove 4 screws.
- (7) Slide the transfer unit to the rear side and raise the front side to take it off.

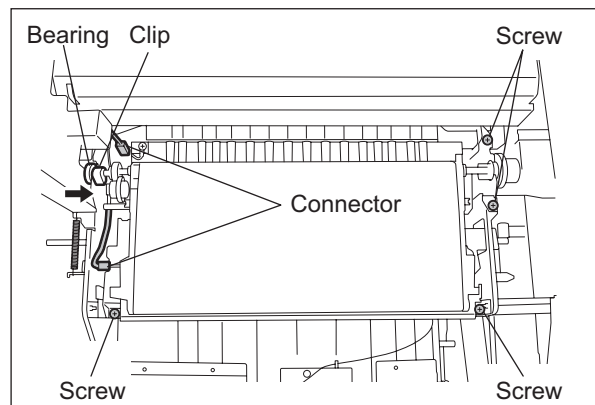

Fig. 12-5

Notes:

1. Change the screw position before performing the transfer belt deviation adjustment.
For the adjustment procedure, refer to "3.10 Transfer belt deviation adjustment" in the SERVICE HANDBOOK.

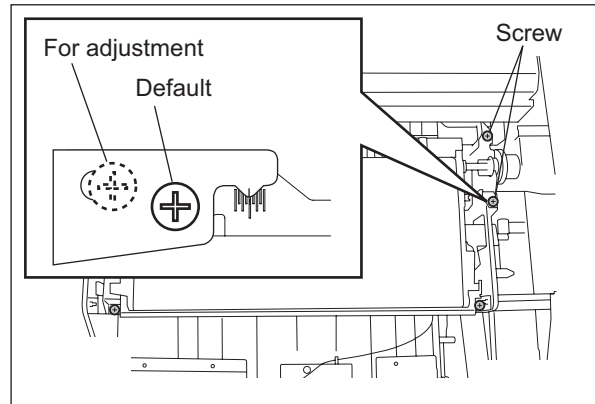

Fig. 12-6

2. When installing the transfer unit, make sure that the lever comes under the cam.

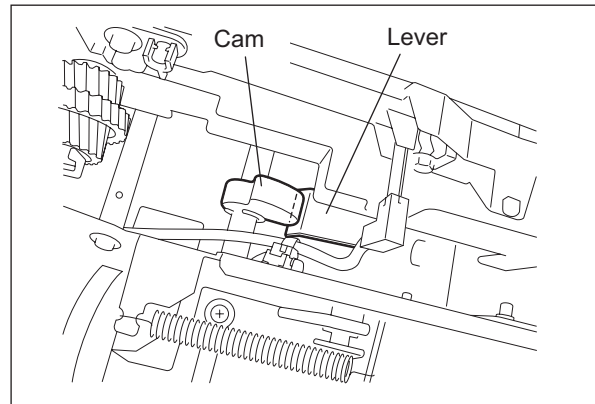



Fig. 12-7

[B] Transfer belt

- (1) Take off the transfer unit.
( P.12-5 "[A] Transfer unit")
- (2) Turn the transfer belt unit 90° and pull it out upward.

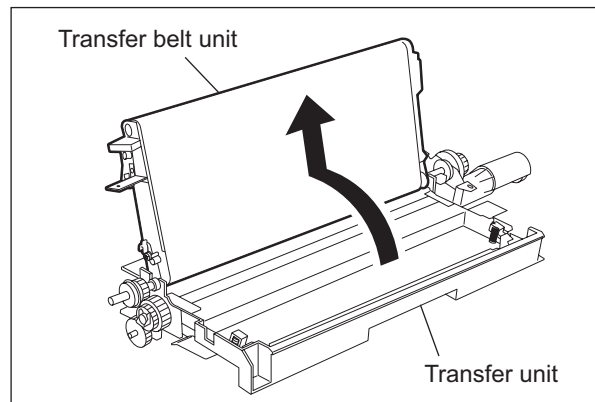

Fig. 12-8

- (3) Remove 2 screws.

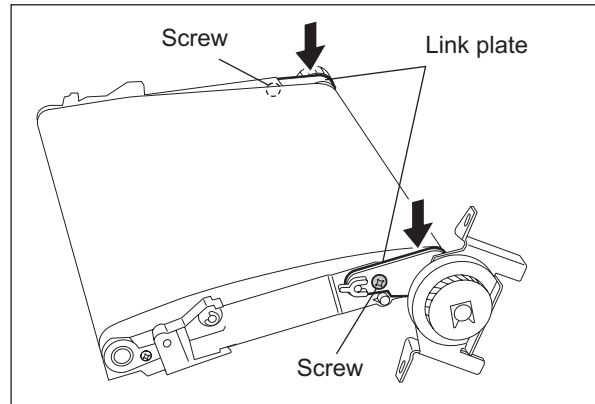

Fig. 12-9

- (4) Turn the driving roller to the direction of the arrow.
 (5) Pull out the transfer belt.

Notes:

1. Install the transfer belt in the middle so that it does not move to one side.
2. Do not touch the surface of the belt.
3. Fix the link plate securely by pressing the rear and front side of the plate to the direction of the arrow.

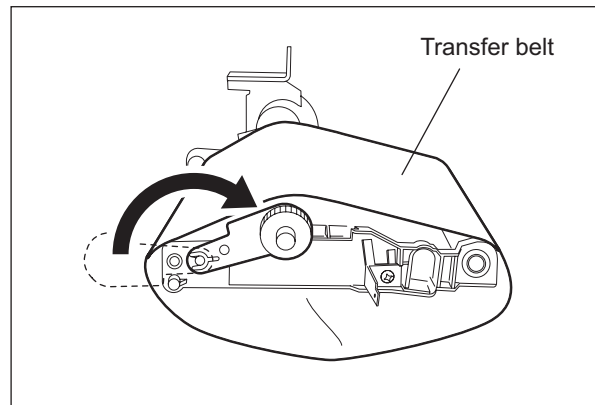

Fig. 12-10

[C] Cleaning brush

- (1) Take off the transfer unit.
(P.12-5 "[A] Transfer unit")
- (2) Take off the transfer belt unit.
(P.12-6 "[B] Transfer belt")
- (3) Remove 1 clip and then 3 gears.

Notes:

1. There are latches on gear "a" and "c". Remove gear "a", "b" and then "c".
 2. When installing the gear, be sure that the latch is securely inserted into the groove of the shaft.
- (4) Remove 1 screw and then the plate spring.
 (5) Slide the transport guide to the rear side to pull it out upward.

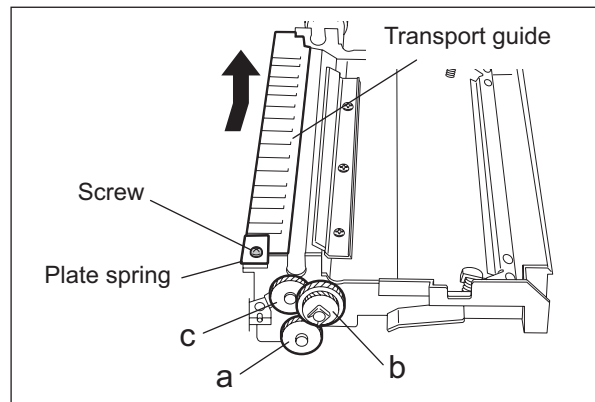

Fig. 12-11

- (6) Remove 1 clip and then the bushing.
- (7) Push the brush to the rear side, take off the shaft on the front side and then pull it out to the upper front side.

Note:

Do not touch the surface of the brush.

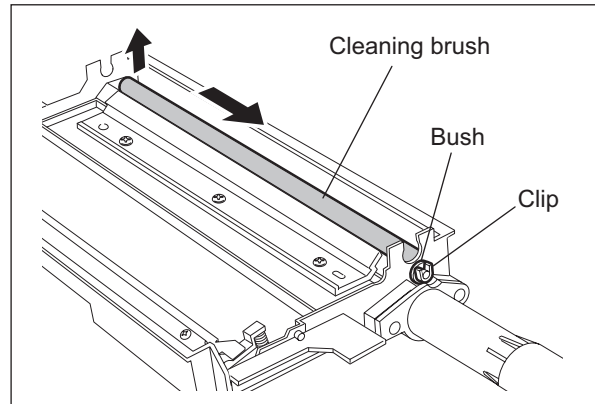

Fig. 12-12

[D] Cleaning blade

- (1) Take off the transfer unit.
(P.12-5 "[A] Transfer unit")
- (2) Remove 3 screws to take off the cleaning blade.

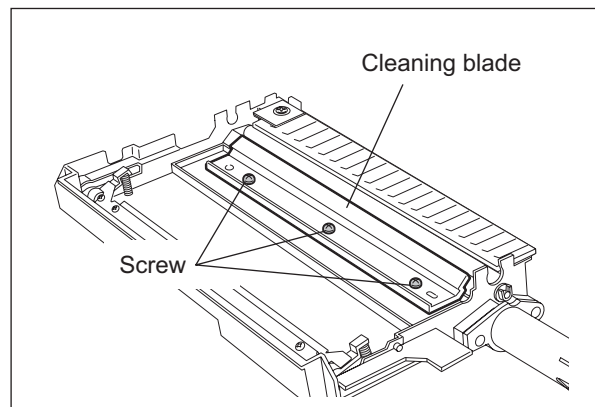

Fig. 12-13

Notes:

1. When installing the blade, fix the boss on both sides with the screws.
2. Be careful not to touch, scratch or damage the blade.
3. After installing the blade, be sure that the seals on both sides are not damaged.

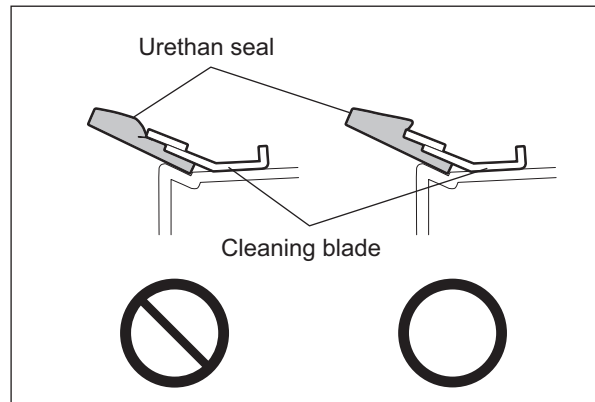

Fig. 12-14

[E] Transfer/Transport unit

- (1) Take off the transfer unit.
(☞ P.12-5 "[A] Transfer unit")
- (2) Take off the fuser unit.
(☞ P.13-17 "[B] Fuser unit")

Note:

Make sure to take off the fuser unit and transfer unit before the transfer/transport unit.

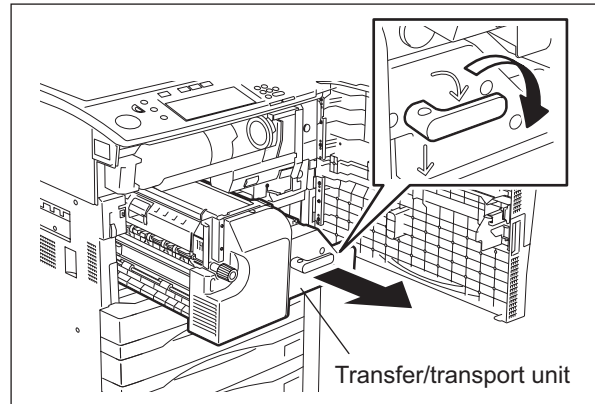

Fig. 12-15

- (3) Remove 2 stepped screws fixing the slide rail.

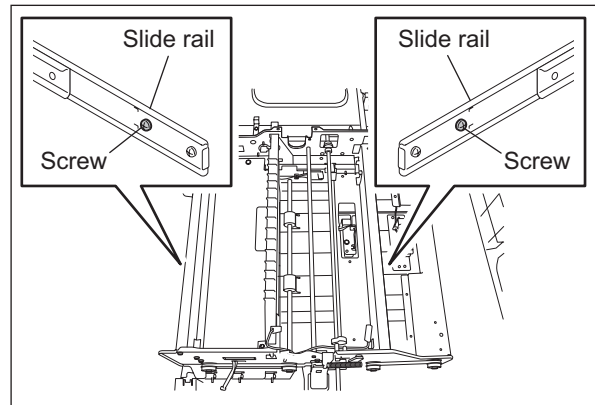

Fig. 12-16

- (4) Hold A (shaft) or B (stay) with your left hand.
- (5) Hold the slide rail on the right with your right hand.

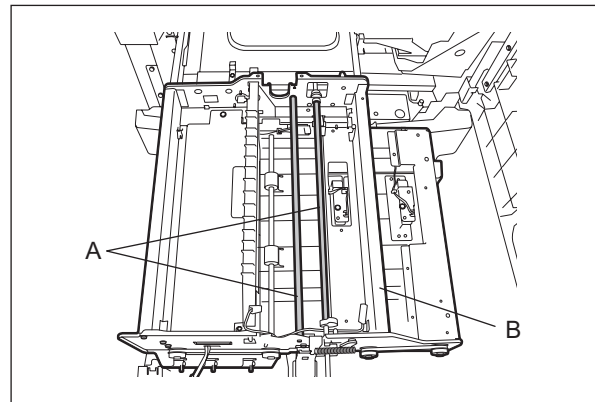

Fig. 12-17

- (6) Lift up the transfer/transport unit to release the hook.
- (7) Push in the slide rail while loosening the slide rail on the right side.

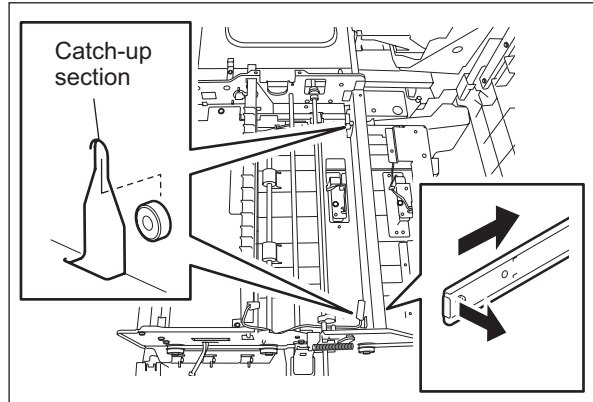

Fig. 12-18

- (8) Shift A or B from your left to your right hand and then hold C in your left hand.
- (9) Take off the transfer/transport unit from the slide rail by lifting it up.

Notes:

- 1. When lifting up the transfer/transport unit, do not hold D (Transport guide) because it may cause damage to the transport guide.
- 2. When installing, follow the procedure below.

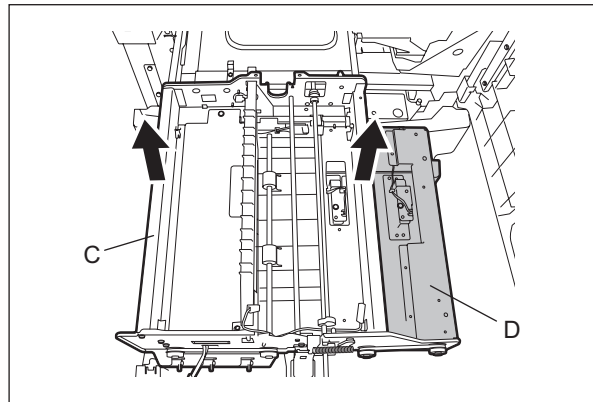

Fig. 12-19

- (10) Pull out the slide rail on the left side completely.
- (11) Hook the transfer/transport unit on the slide rail on the left side properly.
- (12) Extend the slide rail on the right side. Make sure to extend the leading edge of the slide rail completely.
- (13) Hook the transfer/transport unit on the slide rail on the right side.
- (14) Fix the transfer/transport unit with 2 stepped screws.
- (15) Assemble it in the reverse order of the disassembling procedure.

[F] Horizontal transport sensor-1, -2 and -3 (S19, S20, S21)

- (1) Take off the transfer unit.
(P.12-5 "[A] Transfer unit")
- (2) Take off the fuser unit.
(P.13-17 "[B] Fuser unit")
- (3) Remove 1 screw to take off each sensor with its bracket.
- (4) Disconnect 1 connector and release the latch to take off each sensor.

Note:

The horizontal transport sensor-3 (S21) can be replaced without the transport unit being taken off.

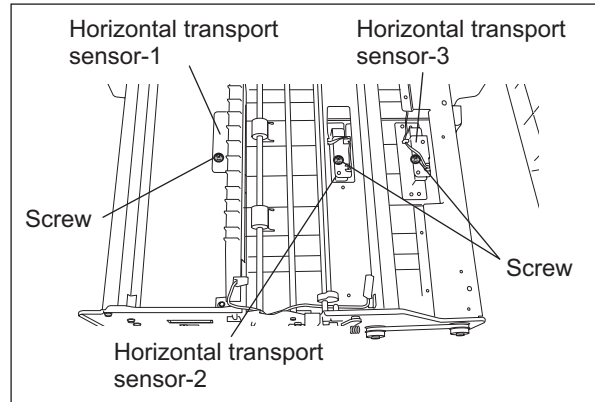

Fig. 12-20

[G] Horizontal transport section driving clutch-2 (CLT2)/ -3 (CLT3)

- (1) Remove the transfer/transport unit.
(P.12-9 "[E] Transfer/Transport unit")
- (2) Disconnect 1 connector and remove 1 E-ring to take off the each clutch.

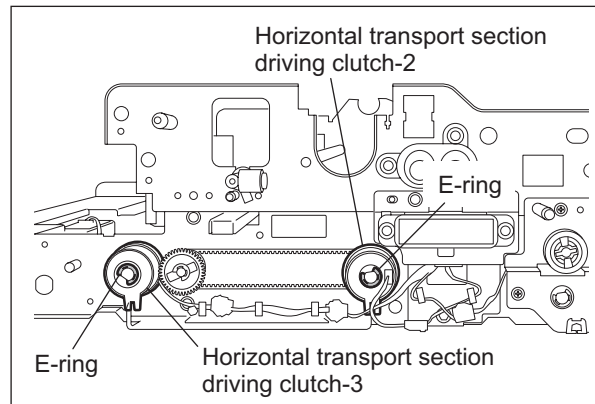

Fig. 12-21

[H] Horizontal transport section driving clutch-1 (CLT1)

- (1) Take off the transfer/transport unit
(P.12-9 "[E] Transfer/Transport unit")
- (2) Disconnect 1 connector.
- (3) Remove 1 E-ring and 3 screws to take off the bracket.

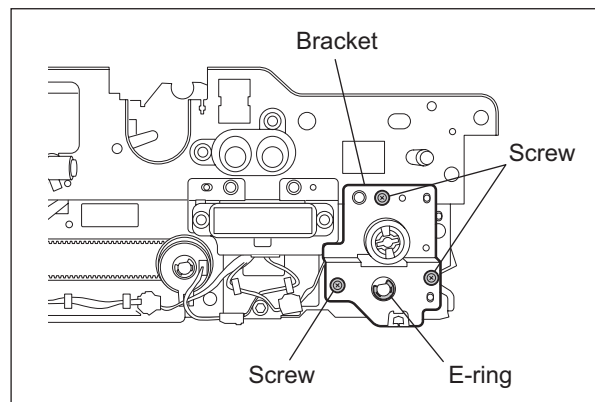

Fig. 12-22

- (4) Take off the driving clutch from the shaft.

Note:

Fix the stopper of the clutch in the "R" marked side.

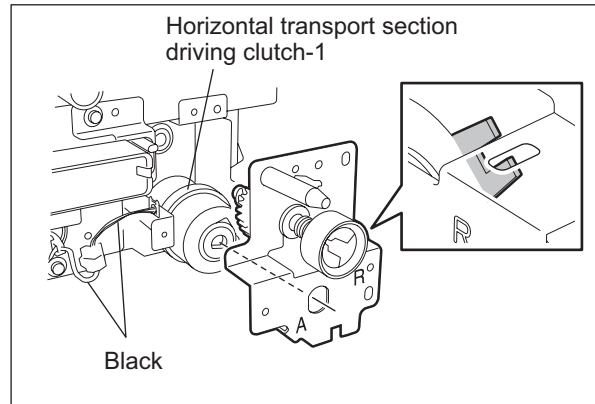

Fig. 12-23

Notes:

1. When fixing the clutch with the E-ring, be sure that the one side of the E-ring latch does not overlap the flat part of the shaft.
2. Be sure that the stopper of the clutch is inserted into the groove of the bracket.
3. Make sure that the bearing and gear are installed correctly.

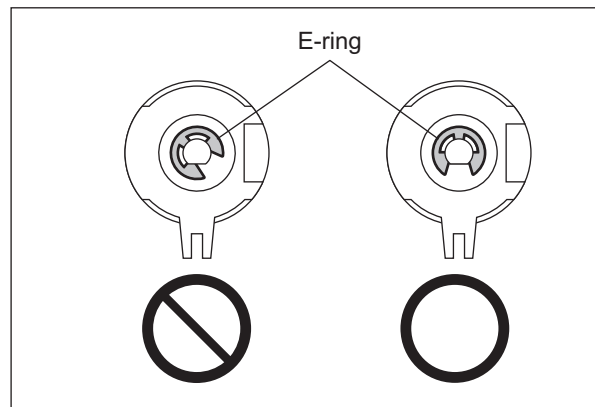

Fig. 12-24

[I] Transfer belt drive motor unit / Transfer belt motor (M14)

- (1) Take off the rear cover.
(📖 P.2-45 "[L] Rear cover")
- (2) Remove 3 screws to take off the flywheel.
- (3) Disconnect 1 connector, and then remove 1 spring and 2 screws to take off the drive motor unit.
- (4) Remove 3 screws to take off the bracket.
- (5) Remove 2 screws to take off the transfer belt motor.

Note:

When installing the motor, fix it by rotating it counterclockwise.

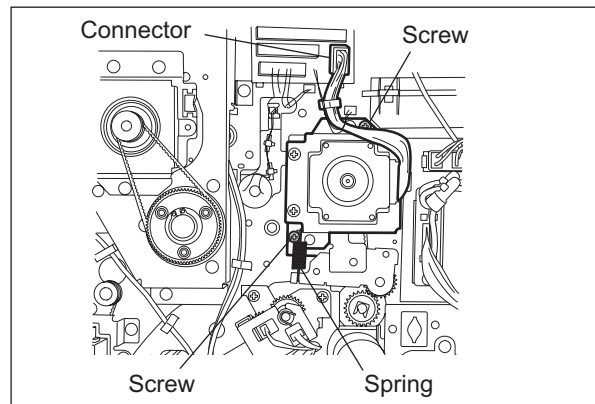



Fig. 12-25

[J] Transfer belt contact/release cam driving unit

- (1) Take off the rear cover.
( P.2-45 "[L] Rear cover")
- (2) Remove 3 screws to take off the flywheel.
- (3) Disconnect 1 connector and remove 2 screws to take off the cam driving unit.

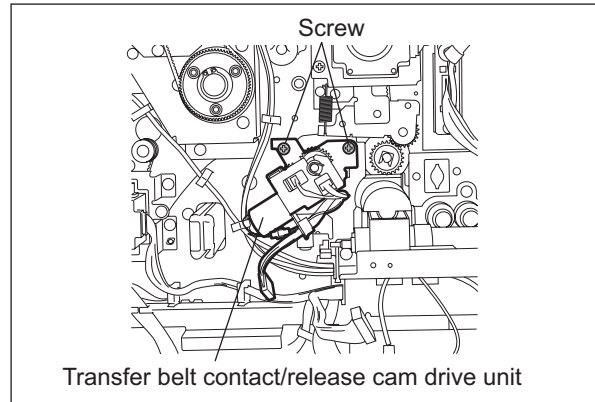

Fig. 12-26

- (4) Remove 1 screw to take off the transfer belt release detection sensor (S15).
- (5) Remove 1 screw to take off the transfer belt contact detection sensor (S16).

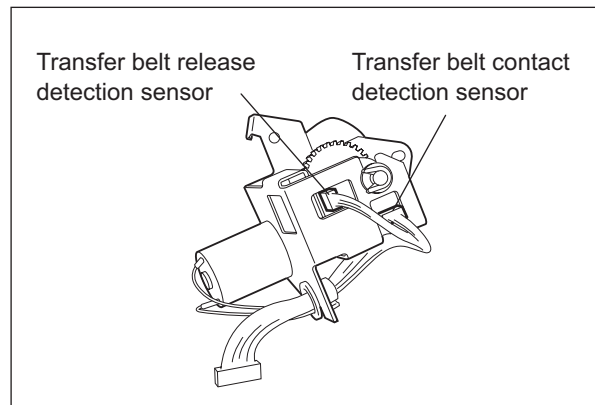



Fig. 12-27

[K] Transfer belt cam motor (M15)

- (1) Take off the transfer belt contact/release cam driving unit.
( P.12-13 "[J] Transfer belt contact/release cam driving unit")
- (2) Remove 2 screws and disconnect 1 connector to take off the transfer belt cam motor.

Note:

Pay attention to the size (length) of the screws. If incorrect ones are used, the motor could be damaged.

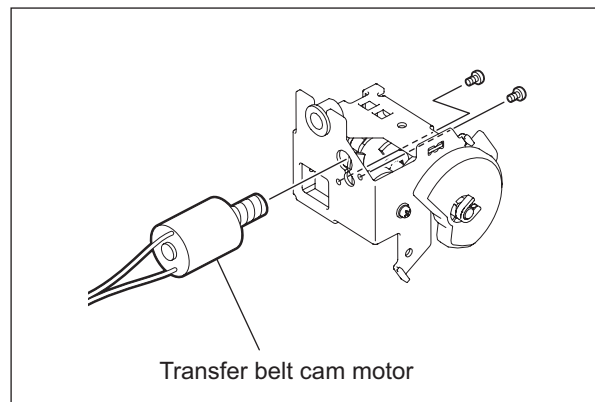

Fig. 12-28

13. FUSER UNIT

13.1 Outline

The toner is fused on the paper separated from the photoconductive drum by having heat and pressure applied to it. The paper is then discharged through the paper exit section. The fuser unit consists of the IH coil (IH-COIL), fuser roller, pressure roller, separation fingers, cleaning web, thermistors (THM1, 2, 3 and 4), thermostat (THMO1 and 2), fuser exit rollers, fuser transport sensor (S9), etc.

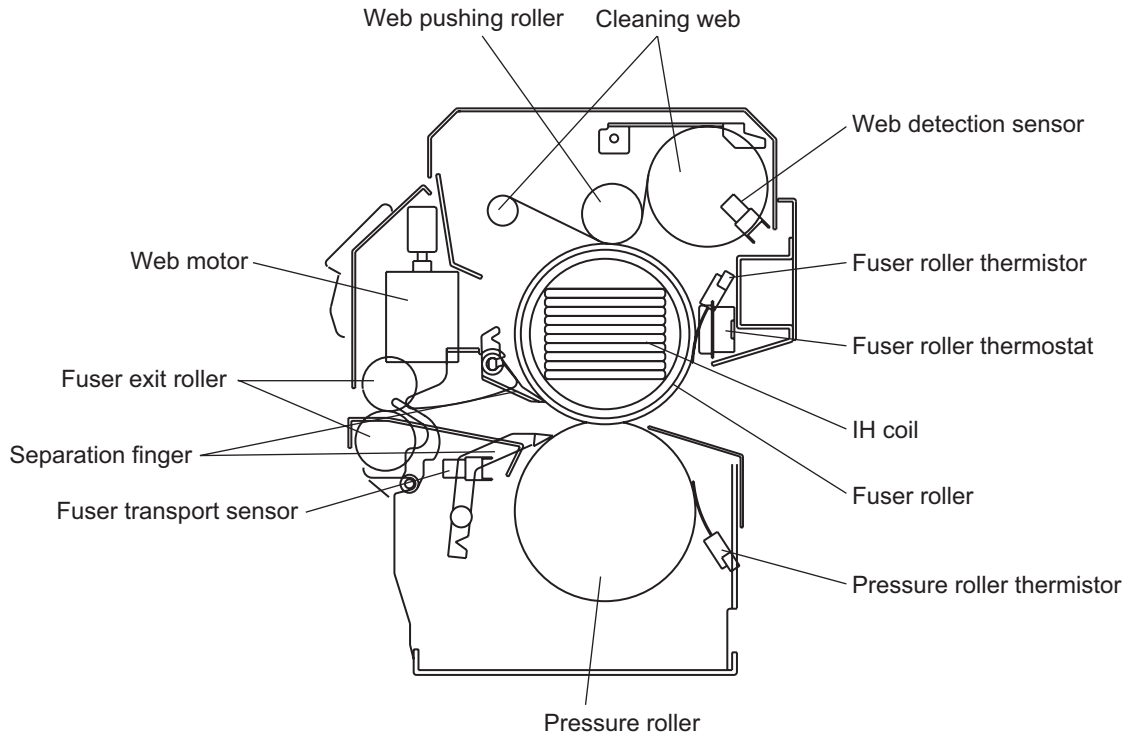

Fig. 13-1

13.2 Operation

At the fuser unit, the toner is fused on the paper which has been separated and transported from the photoconductive drum by having heat and pressure applied to it. The pressure and fuser rollers are rotated by the driving of the fuser motor (M3). The fuser roller has an IH coil (IH-COIL) inside, which does not rotate itself. The fuser and pressure rollers are always pressured by a spring force. After being fused, the paper is separated smoothly from the fuser roller by the separation fingers.

The thermistors (THM1, 2 and 3) detect the fuser roller temperature to control it, and when the temperature becomes abnormally high, which is detected by thermostats (THMO1 and 2), the power supply to the IH coil (IH-COIL) is cut off.

13.3 Functions

- (1) IH coil (IH-COIL) (IH: Induction heating)
The IH coil is inside the fuser roller and applies the induction heat to the fuser roller. This IH coil (IH-COIL) is divided into two parts, the center IH coil heating the center of the fuser roller and the side IH coil heating both ends of the fuser roller. Those parts become ON/OFF separately in order to maintain the fuser roller at a certain temperature without wasting excessive electric power.
- (2) Fuser roller
The fuser roller is made of iron and induction-heated by an IH coil (IH-COIL). It is pressed by the pressure roller, which is mentioned below, and the toner is fused on the paper while the paper is passing between these two rollers with the toner image on the paper facing the fuser roller. So, the toner is made to soak into the fibers of the paper by being melted with the heat of the fuser roller and having heat conductivity improved due to pressure from the pressure roller. The surface of the fuser roller is coated with fluoroplastic to prevent the toner adhering to it (this is called "offset") and help it become separated from the roller.
- (3) Pressure roller
The pressure roller is made of rubber (PFA tube roller) to make it easier to press against the fuser roller and its pressure is always derived from a spring force.
- (4) Separation fingers
The separation fingers are for removing paper that has stuck to the fuser and pressure rollers.
- (5) Cleaning web
The cleaning web is attached touching the fuser roller by means of the web pushing roller to remove any toner or paper dust that has stuck to the fuser roller during the fusing process. It is rolled up by the web motor (M4) with its clean surface always touching the fuser roller. It also contains silicone oil for coating the surface of the fuser roller, which makes it easier to clean up any toner or paper dust.

The cleaning web rolled around the roller has been made thinner and lengthened. This has increased the web rolling up speed and improved the cleaning performance. The cleaning web's cleaning performance is the same as that of the cleaning roller, so this equipment does not have a cleaning roller.
- (6) Fuser exit roller
The fuser exit roller transports the paper separated from the fuser and pressure rollers with the separation fingers through the fuser unit.
- (7) Fuser transport sensor (S9)
This sensor is for detecting that the trailing edge of the paper has reached the fuser unit exit sensor and also for the detecting of paper jams at the fuser unit exit section.
- (8) Fuser roller center thermistor (THM2) and Fuser roller rear thermistor (THM3)
These thermistors (THM2 and 3) detect the temperature of the fuser roller to maintain it within a certain range, which is higher than the lower limit which would cause poor fusing and lower than the upper limit which would cause a high temperature offset. When the temperature of the fuser roller is lower than the preset temperature, it is turned ON to supply power to the IH coil (IH-COIL), and when it is higher than the preset temperature, it is turned OFF to cut the supply. It also detects the slight difference of the temperatures at the center and rear end of the fuser roller to control the ON/OFF of the center and side IH coil to keep the fuser roller at a certain temperature.

- (9) Fuser roller front thermistor (THM1)
This thermistor cannot be used for the temperature control of the fuser roller. It detects a temperature abnormality at the side area of the fuser roller where the paper does not pass through.
- (10) Fuser roller center thermostat (THMO1) and Fuser roller side thermostat (THMO2)
These thermostats cut off the power supply to the IH coil (IH-COIL) when the fuser roller becomes abnormally hot as the result of a problem such as a thermistors (THM1, 2 and 3) malfunction. The thermostats (THMO1 and 2) of this equipment are used to prevent abnormal operation, and when any abnormality is detected, they must be replaced altogether with the other damaged parts of the fuser unit.

13.4 Fuser Control Circuit

13.4.1 Configuration

A forcible power OFF circuit is embedded in this equipment. This circuit detects the overheating of the fuser unit with the thermistors installed on it. When the surface temperature of either the fuser roller or the pressure roller has exceeded the specified value, the circuit sends the relay ON signal in order to shut off the power supply throughout the unit.

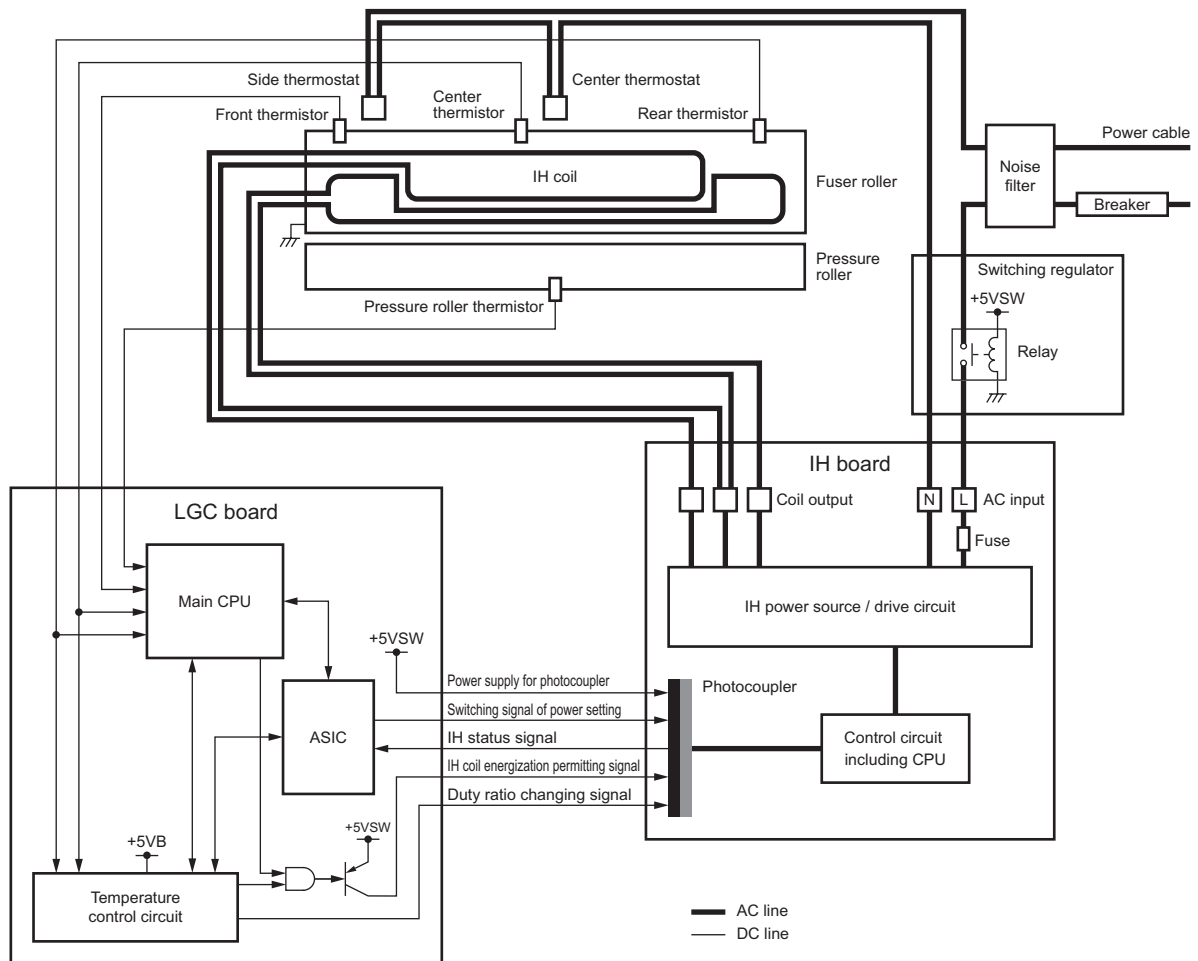

Fig. 13-2

13.4.2 Heating principle of IH coil

The magnetic field is generated by applying a high frequency current to the IH coil inside the fuser roller, which then produces the eddy current in it. When the eddy current flows, the Joule heat is generated by the resistance element of the fuser roller, which is then heated. In the IH coil method, the thermal efficiency is higher than the lamp method because the fuser roller is directly heated.

IH coil is divided into two parts to decrease the temperature difference between the center and both ends of the fuser roller.

Image of current flowing from A to B

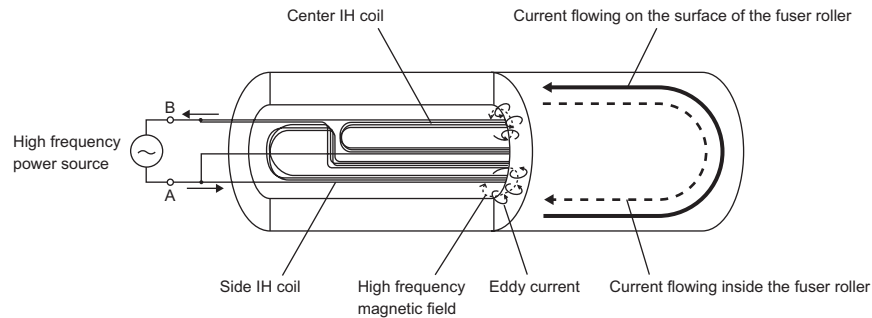

Fig. 13-3

Block diagram of IH board

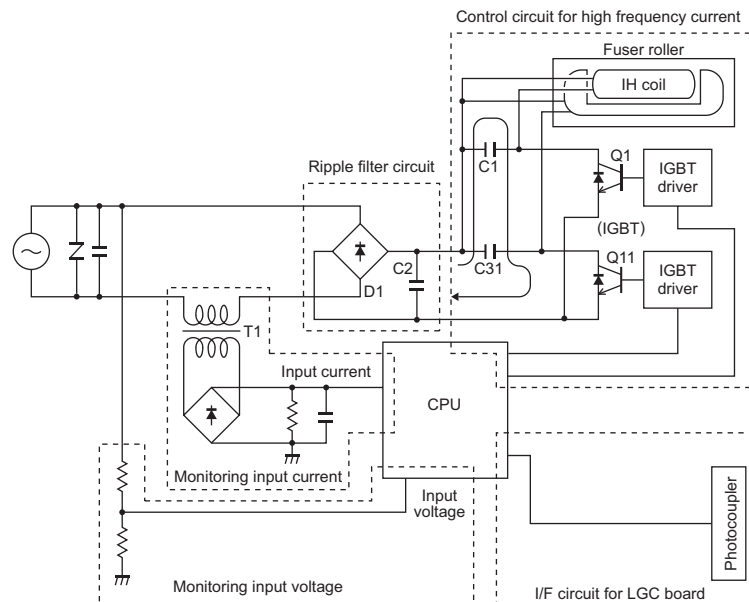

Fig. 13-4

13.4.3 IH control circuit interface

The IH control circuit uses a photocoupler as an insulator against the secondary circuit. The interface signals are as followed.

Connector No.	Signal	Direction	Definition
CN455-1	IH2ON	LGC board to IH board	IH coil energization permitting signal
CN455-2	+5VSW		-
CN455-3	H1PWR1		Switching signal of power setting
CN455-4	H1PWR2		
CN455-5	H1PWR3		
CN455-6	H2PWR1		
CN455-7	H2PWR2		
CN455-8	H2PWR3		
CN455-9	IH1ON		IH coil energization permitting signal
CN455-10	SG		-
CN455-11	IHDUTY	Duty ratio changing signal	
CN455-12	IHERR1	IH board to LGC board	IH status signal
CN455-13	IHERR2		
CN455-14	IHERR3		

13.4.4 Abnormality in the IH control circuit

When an abnormality is detected in the IH control circuit, it stops the power supply to the IH coil and displays a message "call for service".

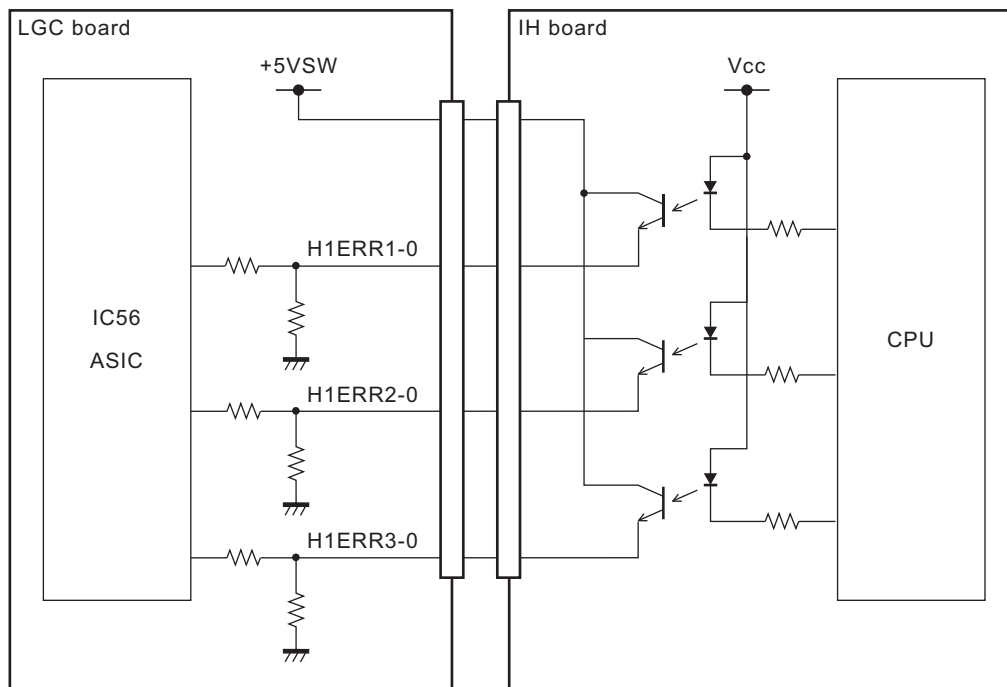

Fig. 13-5

Relation between IH status signal and IH errors (L: Low level, H: High level)

Checking timing	Signal			Status	Error code	Counter (08-400)
	IHERR1	IHERR2	IHERR3			
Front cover (upper) is closed at power ON	L	L	L	Abnormality detected at initialization * An abnormal status is detected at the initialization.	C471	11
On usual				Power voltage abnormality * AC power is not supplied to the IH board.	C472	12
	L	L	H	Power voltage upper limit abnormality (Surge detection) * AC input voltage has exceeded 122% of the rated voltage	C473	13
	L	H	L	Switching element (IGBT) abnormality * Wire breakings, short-circuits abnormal fluctuations or overheating (= insufficient cooling) of IGBT	C481	14
	L	H	H	IH abnormality	C480	15
	H	L	L	No abnormality	-	-
	H	H	H	Power voltage lower limit detection (not error) * AC input voltage has dropped to less than 85% of rated voltage	-	-
	H	H	L	Input current lower limit abnormality * Wire breakings or improper installation of IH coil	C490	17
	H	H	H	Power voltage lower limit abnormality * AC input voltage has dropped to less than 75% of rated voltage	C474	16
	Front cover (upper) is opened	L	L	X	Power voltage abnormality when the front cover (upper) is opened * An abnormal status is detected when the cover is opened	C475
	(Other than the above)					

13.4.5 Temperature detection section

To maintain the fuser roller at a constant temperature, the two fuser roller thermistors (front and rear) detect the fuser roller temperature and control the on/off of the IH coil. The abnormal temperature of the IH coil is detected by the three fuser roller thermistors (front, center and rear), while that of the pressure roller is detected by the pressure roller thermistor.

1. Relation between the thermistor output voltage and surface temperature of the fuser roller

Output voltages of thermistors [V]	Surface temperatures of fuser roller [°C]
Approx. 0.5	40
Approx. 2.0	100
Approx. 3.4	160
Approx. 3.6	170
Approx. 3.8	185
Approx. 4.0	200

2. Control of the surface temperature of the fuser roller

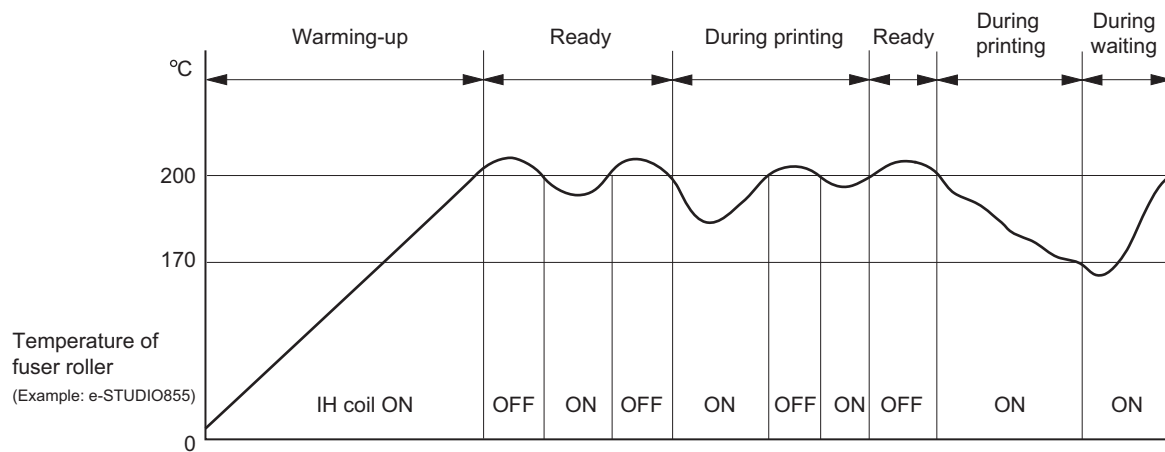

Fig. 13-6

3. Temperature control for the both ends of the fuser roller
 During a continuous printing, the temperature of the both ends of the fuser roller (areas where the paper does not pass on) tends to be higher than that of the other areas (where the paper passes on). For this reason, the temperature of the both ends of the fuser roller is detected by the fuser roller front thermistor. If this thermistor has detected an abnormal temperature (270°C or above), the IH coil is preferentially turned off regardless of the temperature of the areas where the paper passes on.

4. Temperature control at Energy Saving Mode
 This equipment has the following two types of temperature control for saving energy and returns to ready status to perform printing in each mode upon printing request.
 The period of time from the printing request to this mode can be set in "Setting Mode (08)" or by an administrator.

Administrator setting procedure:

[USER FUNCTIONS] button → [ADMIN] (input of administrator's password) → [GENERAL] → [ENERGY SAVER]

Auto Power Save Mode (Setting Mode (08-205)):

When the printing is not performed in a specified period of time (default setting: 15 min.) after the previous printing is completed, the equipment enters to Auto Power Save Mode to turn OFF the IH coil.

Auto Shut Off Mode (Setting Mode (08-206)):

When the printing is not performed in a specified period of time (default setting: 90 min).

* after the equipment entered to Auto Power Save Mode, the equipment then enters to Auto Shut Off Mode to turn OFF the IH coil.

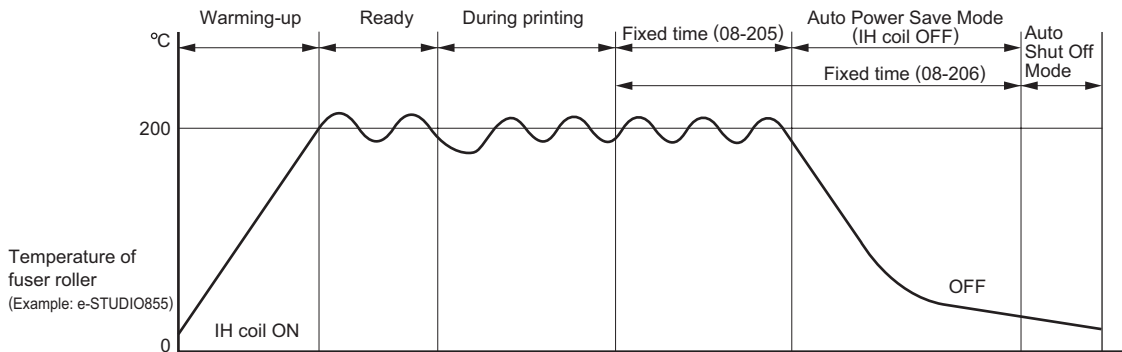

Fig. 13-7

5. Fuser unit error status counter control

- To enhance the safety of the fusing section unit, main-CPU provides the following protection: When the third [C411] error has occurred after two consecutive [C411] errors, the IH coil is not turned ON and error [C412] is displayed immediately even if an operator turns OFF the power and back ON. However, if the equipment goes into a ready state normally with the fuser unit error status counter "1" or below, the counter is cleared to "0".
- If the error codes [C411] to [C490] are displayed and still not cleared even though the thermistor, thermostat and IH coil have been repaired (and the power ON/OFF does not clear the error), check the Setting Mode (08-400) to set the fuser unit error status counter to "0".

Remark:

The fuser unit error status counter (Setting Mode (08-400)) never has values other than 0 to 29.

- If the IH coil does not turn ON and the service call [C411] or [C412] is displayed immediately after the power is ON, ensure the fuser unit error status counter is "2" or over. If it is "2" or over, be sure to check the thermistor, thermostat and IH coil. Reset the counter to "0" after repairing them, then turn ON the power.
- If the fuser unit error status counter is "30" or over (e.g., 31), the data in NVRAM or NVRAM itself may possibly have been ruined due to causes such as leakage from the chargers. Check the bias, high-voltage transformers and charge wires to see if any of them is defective, and also look through all the data in the NVRAM.
- When the thermistors detect overheating, the main-CPU decides the error code and counter value of the fuser unit error status. After turning OFF each output (the IH coil, exposure lamp, control panel display, motors and so on), the main-CPU turns OFF the power to protect the fuser unit.

Error code: C449 ([C] and [8])

Counter value of the fuser unit error status: 9 (08-400)

Thermistors continue detecting the abnormal temperature even after the error codes and counter values are decided. Even if the power is turned ON immediately, it is automatically turned OFF again when the surface temperature of the fuser roller is still higher than the abnormal temperature detected.

Wait until the surface temperature of the fuser roller is lowered enough, and turn ON the power to check the counter value while it is turned OFF again. After confirming that it is the fuser unit abnormality, correct the abnormality and reset the counter value (08-400) to "0" to start up the equipment normally.

6. Temperature detection circuit

Thermistors are elements whose resistance decreases as they detect a higher temperature. Thus, the input voltage to the main-CPU is changed and the main-CPU judges whether this change is abnormal or not. If one of these thermistors is broken, the control circuit judges that the temperature of the fuser roller or the pressure roller is extremely low. Then the circuit keeps turning the IH coil on. As a result of this, the fuser roller temperature rises, and this may activate the thermostats, a safety protection element. To prevent this problem in advance, the main-CPU works to detect the wire breaking of each thermistor.

These thermistors also check the temperature of the fuser roller or the pressure roller regularly to prevent them from excessive heating caused by a circuit abnormality or a thermistor abnormality. If the temperature of these rollers has exceeded a specified level, the thermistors automatically turn the power of the equipment OFF.

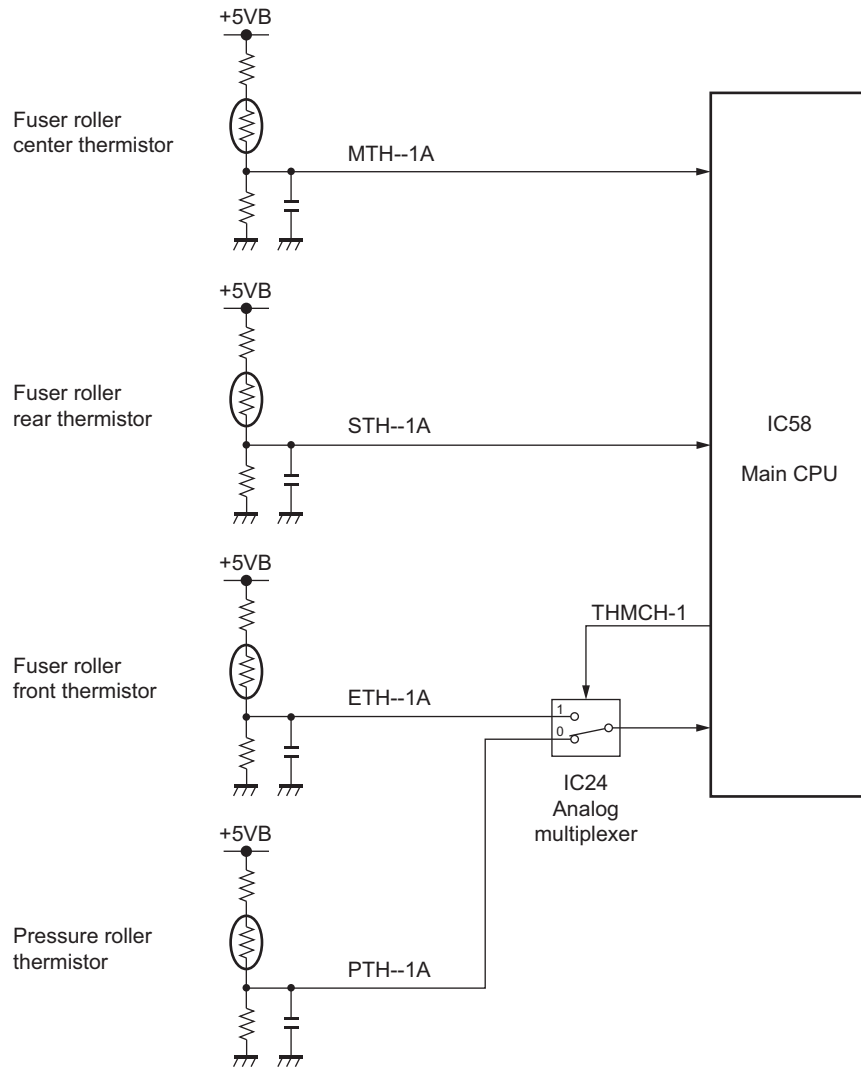

Fig. 13-8

7. Abnormality detection by the thermistors

The table below shows the judging conditions of abnormal temperatures of the fuser roller and the pressure roller, and their checking timing.

Checking timing	Condition	Temperature judged				Error code	Counter (08-400)	Error judging timing	
		Center thermist or	Rear thermist or	Front thermist or	Pressure roller thermist or				
Power ON	1	240°C or above	-	-	-	C449	9	Power ON	
		-	250°C or above	-	-				
		-	-	270°C or above	-				
		-	-	-	250°C or above	C468	8		
	2	40°C or below	150°C or above	-	-	C412	2		
		150°C or above	40°C or below	-	-				
Detecting 40°C	1	240°C or above	-	-	-	C449	19	On usual	
		-	250°C or above	-	-				
		-	-	270°C or above	-				
		-	-	-	250°C or above	C468	18		
	2	40°C or below	-	-	-	C412 (C411)	2 (1)		Fixed time
		-	40°C or below	-	-				
Detecting 100°C	1	240°C or above	-	-	-	C449	21	On usual	
		-	250°C or above	-	-				
		-	-	270°C or above	-				
		-	-	-	250°C or above	C468	18		
	2	100°C or below	-	-	-	C446 (C443)	3 (6)		Fixed time
		-	100°C or below	-	-				
When pre-running end temperature / ready temperature is detected	1	240°C or above	-	-	-	C449	22	On usual	
		-	250°C or above	-	-				
		-	-	270°C or above	-				

Checking timing	Condition	Temperature judged				Error code	Counter (08-400)	Error judging timing
		Center thermistor	Rear thermistor	Front thermistor	Pressure roller thermistor			
During ready	1	240°C or above	-	-	-	C449	23	On usual
		-	250°C or above	-	-			
		-	-	270°C or above	-			
	2	40°C or below	-	-	-	C447	7	
		-	40°C or below	-	-			
		-	-	40°C or below	-			
		-	-	-	0°C or below			
During printing	1	240°C or above	-	-	-	C449	25	On usual
		-	250°C or above	-	-			
		-	-	270°C or above	-			
	2	40°C or below	-	-	-	C447	24	
		-	40°C or below	-	-			
		-	-	40°C or below	-			
		-	-	-	0°C or below			
At Energy Saving Mode	1	240°C or above	-	-	-	C449	27	On usual
		-	250°C or above	-	-			
		-	-	270°C or above	-			
		-	-	-	250°C or above			
At paper jam	1	240°C or above	-	-	-	C449	29	On usual
		-	250°C or above	-	-			
		-	-	270°C or above	-			
		-	-	-	250°C or above			

* The figures in the "Condition" field denote the priority of error checking.

* The figures in the "Error code" and "Counter" fields with parentheses denote that an error status has not yet been determined (= error status is detected only once).

13.5 Fuser Motor Control Circuit

The fuser motor, which is a DC motor driven by control signals from the ASIC on the LGC board, drives the fuser roller.

A driving PC board is embedded in this motor to perform the following controls.

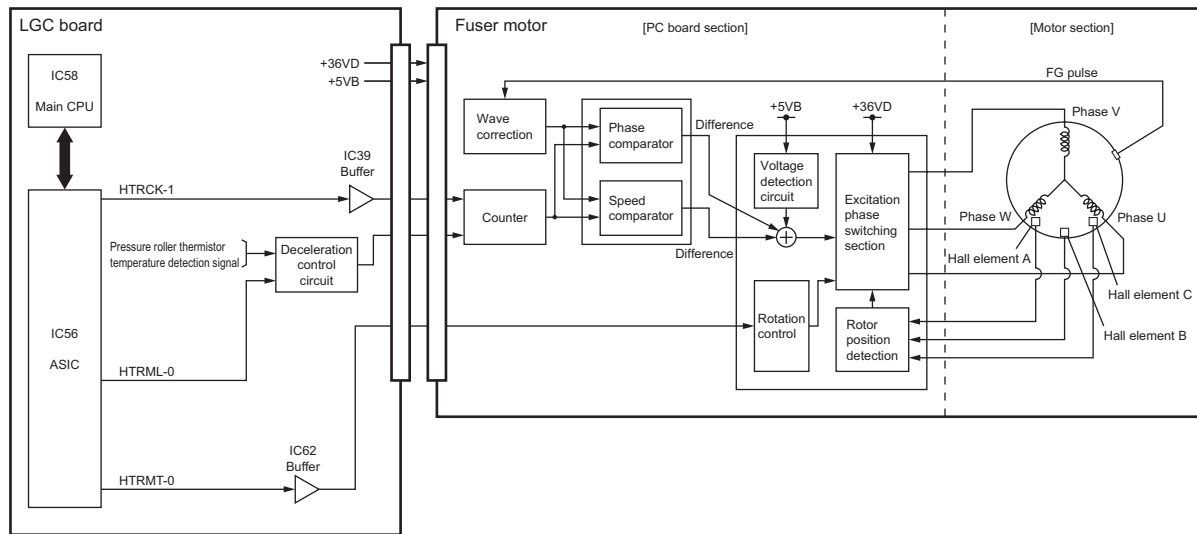

Fig. 13-9

1. ASIC outputs the control signals for the fuser motor rotation.
(HTRMT signal: Motor rotation command)
2. The excitation phase switching section excites each phase of the fuser motor.
→ The fuser motor is rotated.
3. Hall elements A, B and C detect the rotation position of the motor (rotor).
4. The excitation phase switching section switches the excitation of each phase.
(The motor keeps rotating by repeating from 2 to 4.)
5. An FG (Frequency Generator) pulse is generated by the rotation of the motor.
6. The FG pulse and the reference frequency (HTRCK-1) from the ASIC are compared in terms of the phase and speed, and the difference is added to the excitation phase switching section.
Fluctuations in the power supply voltage are also added to the value. (Signal generation)
7. According to the result of step 6), the switching timing of the excitation phase switching section is changed, namely, the FG pulse and the reference clock are controlled to be equal.
→ The fuser motor is rotated at a constant speed. (= Lock range)
8. When the HTRMT signal moves to a high level, the fuser motor is stopped.
9. When the pressure roller temperature is lowered to less than the reference value during the ready status, the HTRML signal output from the ASIC moves to a low level. Thus the motor is rotated at a low speed.

Control signal of fuser motor

- HTRMT signal:
This signal switches the on/off of the fuser motor. When this signal moves to a low level, the motor is rotated, and when this moves to a high level, the motor is stopped.
- HTRCK signal:
This signal is a reference clock which keeps the fuser motor rotation at a constant speed. When the cyclic change of the FG pulse period against this reference signal is within $\pm 6.25\%$, this is defined as a lock range (= the normal rotation of the motor). When the cyclic change is within this range, the LED on the driving PC board of this motor is lit.
- HTRML signal:
This signal rotates the fuser motor at a low speed. When this signal moves to a low level, the motor is rotated at a low speed, and when this moves to a high level, the motor is rotated at a high speed.

13.6 Disassembly and Replacement

Notes:

When assembling or disassembling the fuser unit, be careful of the following items to avoid the harnesses catching or other problems:

1. When installing the stay, be sure not to catch the harness on the screw or the driver.
2. Be sure that the harness is fixed with the clamp and it is not protruding out of the stay.
3. Connect the drawer connector securely.
4. Be sure that the harness of the web detection sensor is arranged within the stay as shown in the figure, and that it is not sagging.
5. Be sure that you arrange the harness of the pressure roller thermistor while bypassing the shaft as shown in the figure.
6. Be sure that the harness of the web motor runs through the harness clamp.
7. When installing the fuser unit front cover, be sure not to catch the connector of the web motor.

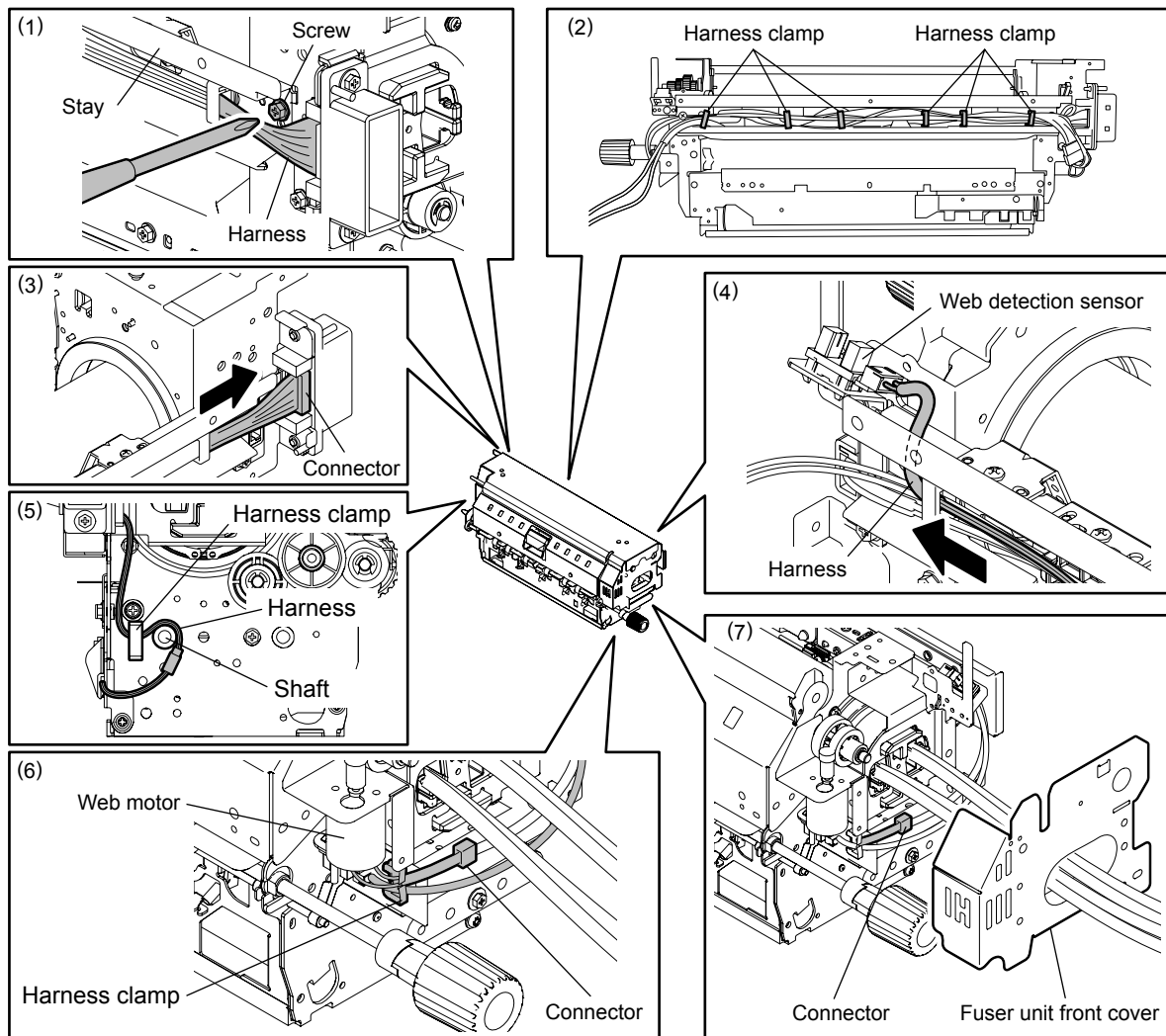

Fig. 13-10

[A] Heater control PC board (IH board)

- (1) Open the front cover. Then pull out the transfer/transport unit by turning its handle clockwise.

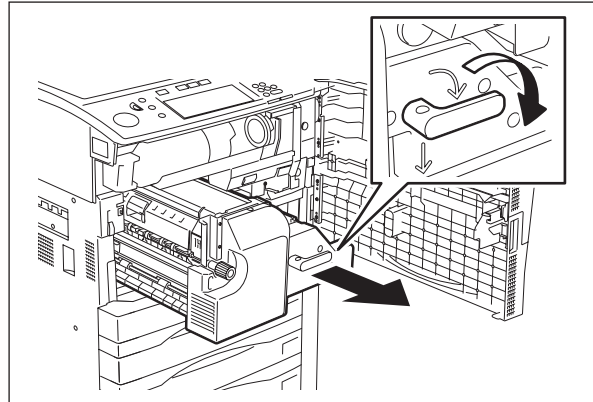

Fig. 13-11

- (2) Remove 2 screws and open the IH cover-1 carefully to the front side.

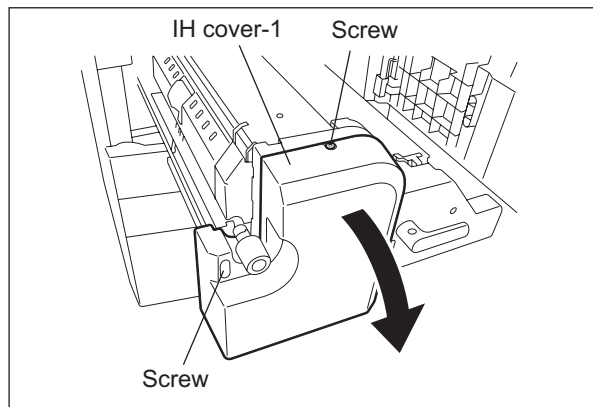

Fig. 13-12

- (3) Remove 4 screws and then release 4 power supply harnesses of the IH coil.

Notes:

1. Be sure that each of these harnesses is connected to the proper position.
2. Use tightening torques of 1.2-2.0 N•m for the 4 screws connecting these power supply harnesses.
3. Since the IH board is a high-voltage section, be sure to pull out the power cable before starting maintenance or checking. Especially do not touch the IGBT when the power is ON since it is generating high-voltage.

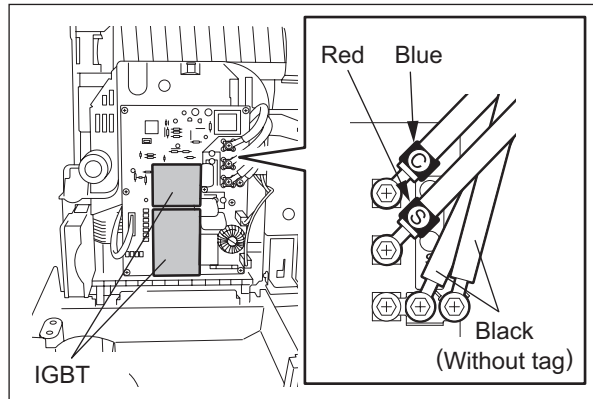

Fig. 13-13

- (4) Disconnect 3 connectors and remove 6 screws to take off the IH board.

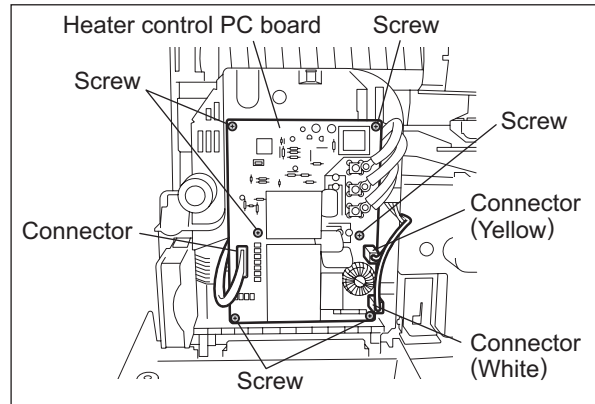

Fig. 13-14

[B] Fuser unit

- (1) Remove 2 screws and open the IH cover-1 carefully to the front side.
- (2) Remove 2 screws to take off a knob cover.

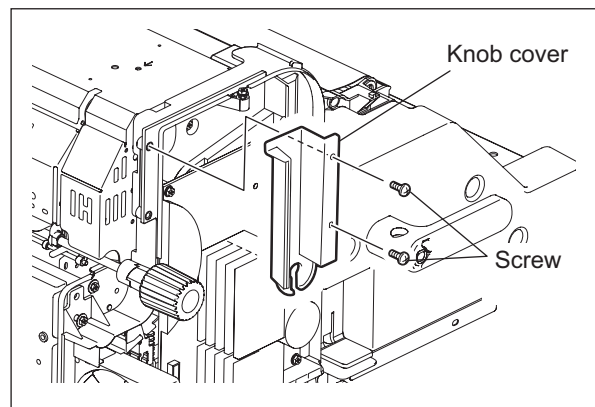

Fig. 13-15

- (3) Remove 4 screws and then release 4 power supply harnesses of the IH coil.
- (4) Disconnect 4 connectors.
- (5) Remove 2 screws and open the IH cover-2 to the front side.

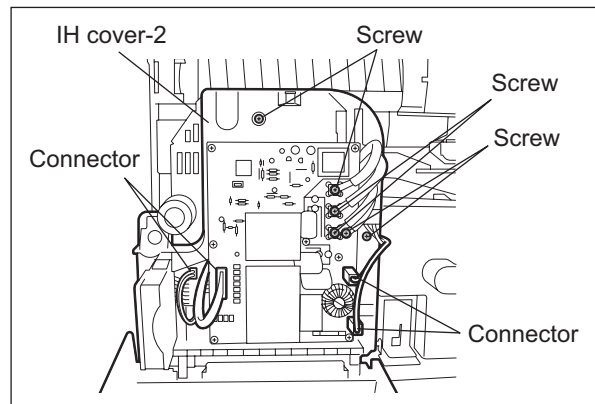

Fig. 13-16

- (6) Remove 1 screw, move the fuser unit forward and lift it off upward.

Notes:

1. When installing or taking off the fuser unit, grab the section "A" in the figure.
2. Be sure that the temperature of the fuser unit has lowered enough before taking it off. If the unit still heated should be taken off, wear a pair of gloves before working.
3. Hold B sections of the fuser unit when installing/removing it.

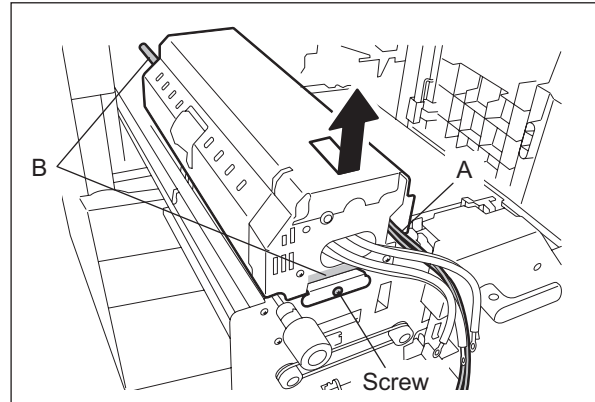

Fig. 13-17

[C] Cleaning web unit / Cleaning web

- (1) Remove 2 black screws to take off the cleaning web unit.

Note:

The cleaning web unit can be taken off without removing the fuser unit.

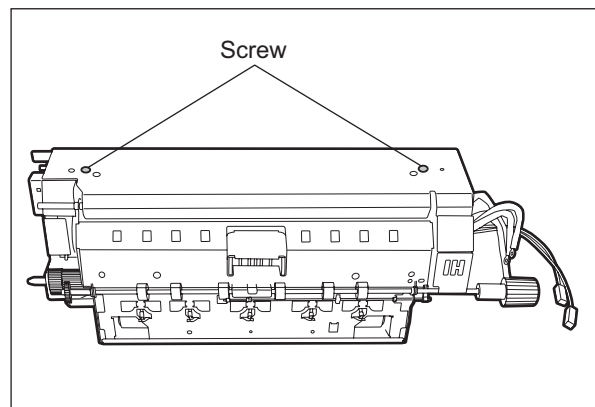

Fig. 13-18

- (2) Remove 4 E-rings. Then remove 4 bushings to take off the cleaning web.
- (3) Remove 1 E-ring, 1 bushing, 1 E-ring, 2 gears, 1 pin, and 1 bushing in order from the shaft.

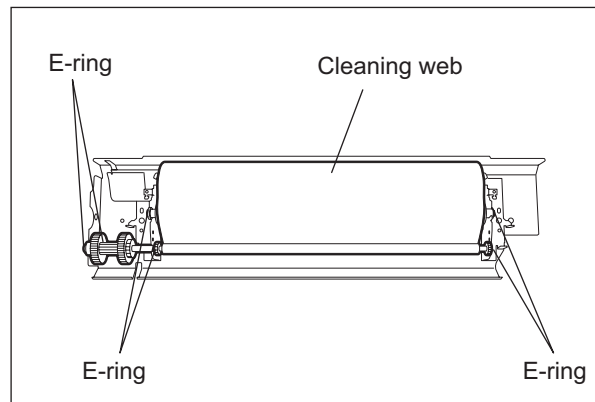

Fig. 13-19

Note:

When the cleaning web has been installed, be sure that the web is tightly reeled.

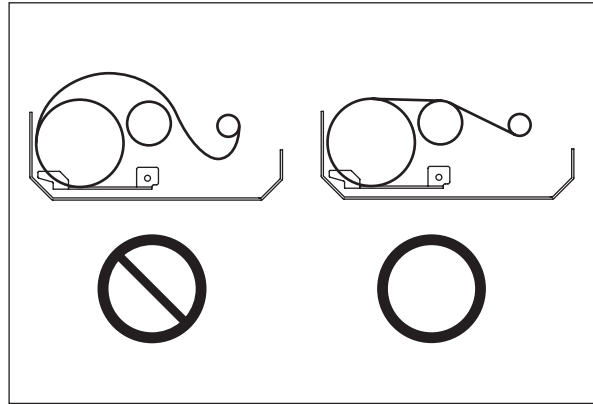

Fig. 13-20

- (4) Remove 2 E-rings, 2 washers, and 2 one-way bearings. Then take off the web pushing roller.

Notes:

1. When assembling the unit, be sure that the one-way bearings are in the correct directions.
2. Be sure that the web pushing roller rolls only in the direction of the arrow in the figure.

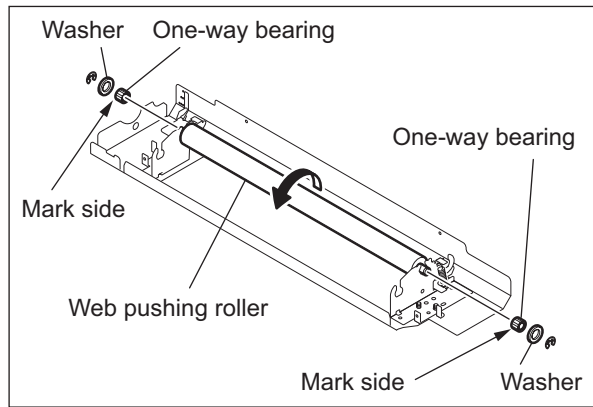

Fig. 13-21

Notes:

1. When replacing the cleaning web, make sure to attach the pin.

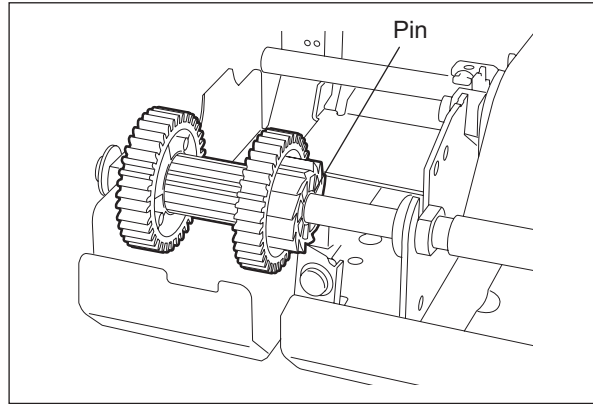

Fig. 13-22

2. The remaining portion of the cleaning web can be checked from the small square hole of the fuser unit.

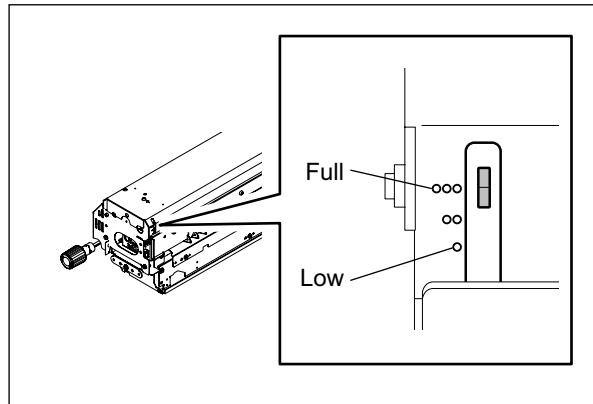



Fig. 13-23

Notes:

When the web has been replaced, check the following items.

1. When the web pushing roller has been replaced, reel the web for 3 to 5 turns by hand.
2. Check if the cleaning web is tightly reeled after it has been installed in the fuser unit.
3. Turn the jam access knob of the fuser unit for 10 to 15 times to fit the web and the fuser roller.
4. Check if there are not any slacks or creases on the cleaning web.
5. Start the PM Support Mode (6S) to reset the counter of the cleaning web. At the first power-ON after this counter reset, the web motor rotates for 65 seconds.
6. Turn the power of the equipment ON. Then confirm that the message "READY" has appeared on the touch panel.
7. Perform the final check of the fuser unit (cleaning web), the same checking as Step 4.
8. When the web motor is rotated at the output check in the Test Mode (03-124), the cleaning web may be slackened. Do not rotate the motor for more than 10 seconds to prevent the web from being slackened.

[D] IH coil

- (1) Take off the fuser unit
( P.13-17 "[B] Fuser unit").
- (2) Take off the cleaning web unit
( P.13-18 "[C] Cleaning web unit / Cleaning web").
- (3) Remove 2 screws to take off the fuser unit front cover.

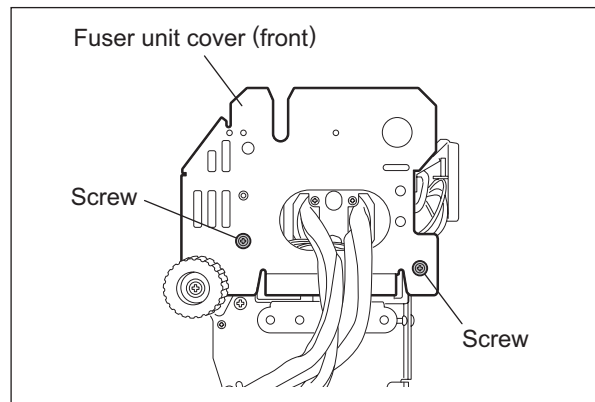
**Fig. 13-24**

- (4) Open 2 clamps and remove 2 connectors.
- (5) Remove 2 screws and take off the bracket.

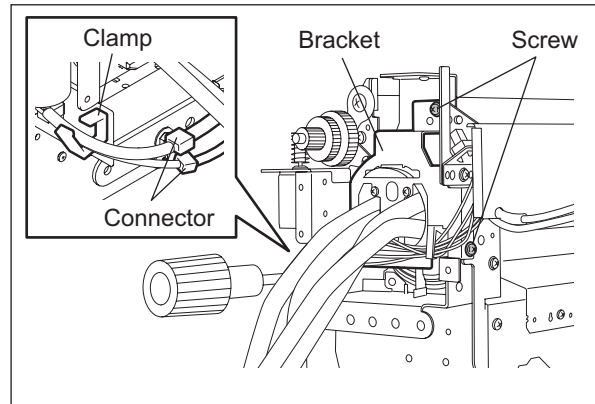

Fig. 13-25

Note:

When installing the bracket, be sure that the harnesses are not caught.

- (6) Pull out the IH coil.

Note:

When installing the IH coil, be sure that the marks "C" and "S" of the power supply harnesses come at the left side.

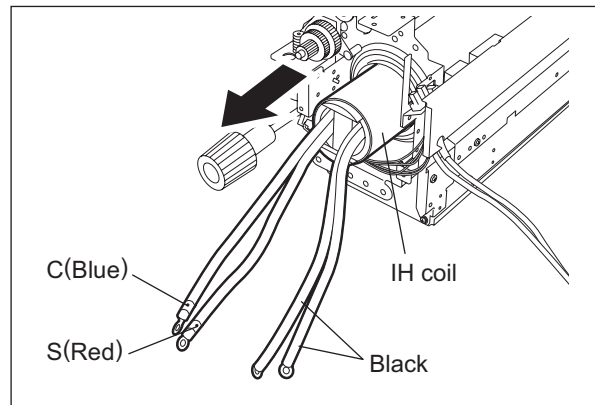

Fig. 13-26

[E] Upper separation finger unit / Upper separation finger

- (1) Take off the fuser unit
(P.13-17 "[B] Fuser unit").
- (2) Take off the cleaning web unit
(P.13-18 "[C] Cleaning web unit / Cleaning web").
- (3) Remove 2 screws to take off the fuser unit front cover.
- (4) Remove 2 stepped screws. Then take off the upper separation finger unit and a crank bracket by sliding them to the rear side.

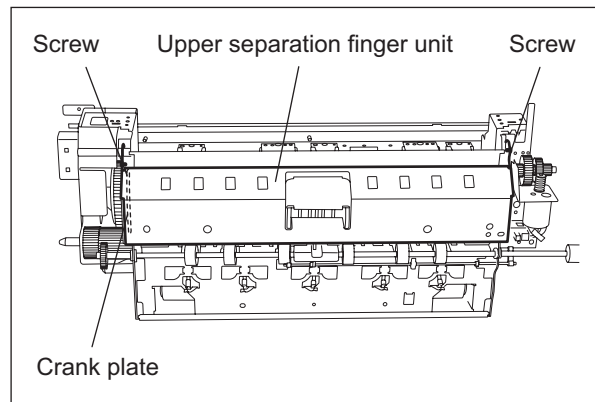

Fig. 13-27

- (5) Remove the spring to take off the upper separation fingers.

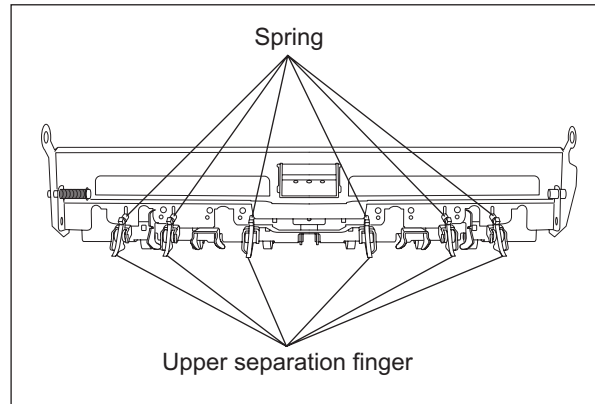

Fig. 13-28

[F] Lower separation finger unit / Lower separation finger

- (1) Take off the fuser unit (P.13-17 "[B] Fuser unit").
- (2) Remove 2 screws and open the lower separation finger unit.
- (3) Remove the spring to take off the lower separation fingers.

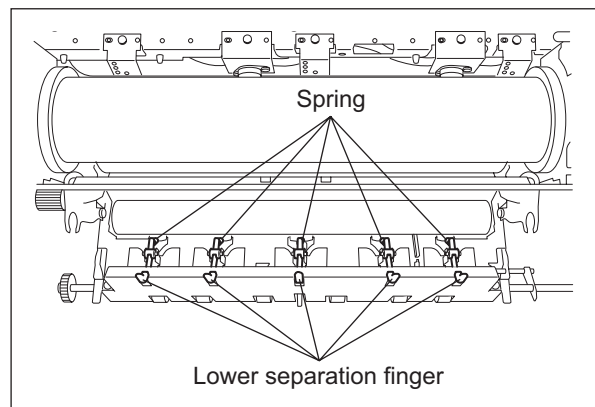

Fig. 13-29

[G] Fuser roller front/center/rear thermistor (THM1 / THM 2 / THM 3), Fuser roller center/side thermostat (THMO1 / THMO2)

- (1) Take off the fuser unit (P.13-17 "[B] Fuser unit").
- (2) Take off the cleaning web unit (P.13-18 "[C] Cleaning web unit / Cleaning web").
- (3) Loosen 2 pressure screws completely.

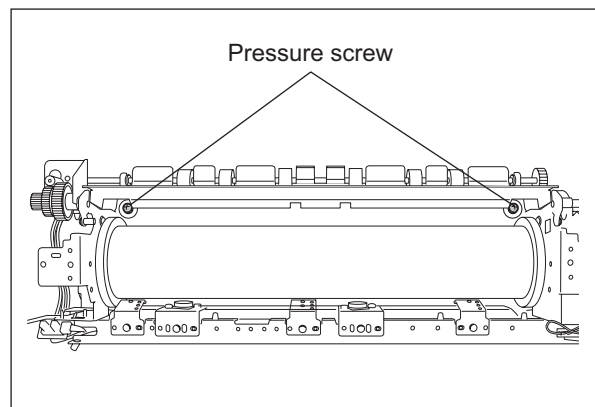

Fig. 13-30

- (4) Remove 2 screws and take off the stay.

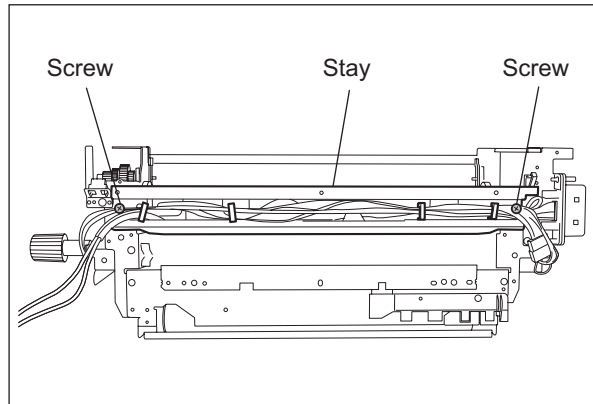

Fig. 13-31

- (5) Disconnect each connector, remove each screw and take off the thermistor and thermostat.

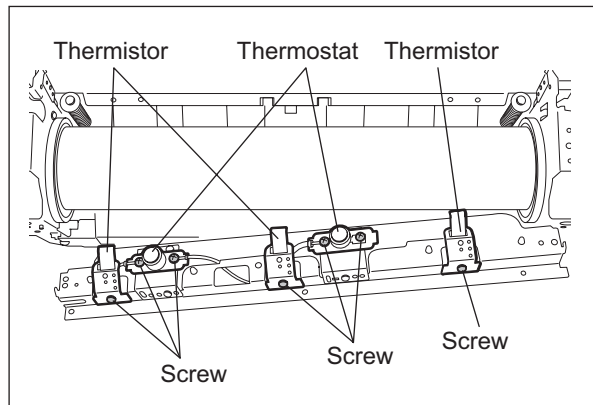

Fig. 13-32

Notes:

1. When installing the thermostats, be careful not to deform the thermostats and their brackets.
2. Adjust the gap between each thermostat and the fuser roller to be 2.0-2.5 mm.

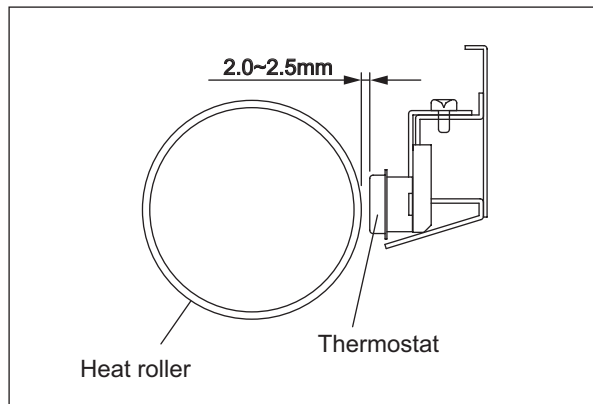

Fig. 13-33

[H] Fuser roller

- (1) Take off the fuser unit
(☞ P.13-17 "[B] Fuser unit").
- (2) Take off the cleaning web unit
(☞ P.13-18 "[C] Cleaning web unit /
Cleaning web").
- (3) Loosen 2 pressure screws completely.

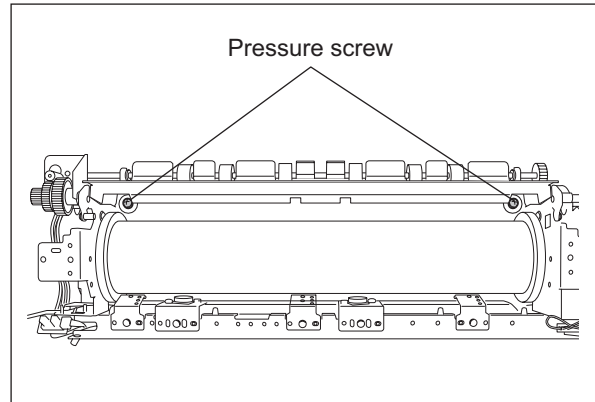

Fig. 13-34

- (4) Remove 2 screws and take off the fuser unit cover (rear).
- (5) Open the lower separation finger unit
(☞ P.13-23 "[F] Lower separation finger unit /
Lower separation finger").
- (6) Remove 2 screws and open the entrance guide unit.

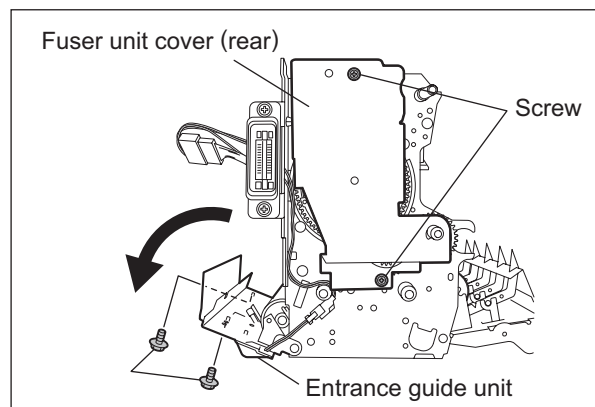

Fig. 13-35

- (7) Remove 2 screws, release 2 harness clamp and take off the bracket with releasing the catching section.

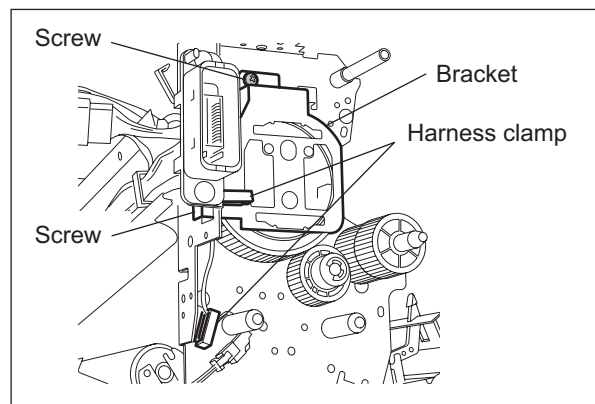

Fig. 13-36

- (8) Remove 2 screws and disconnect 1 connector.
- (9) Remove 1 C-ring (rear).

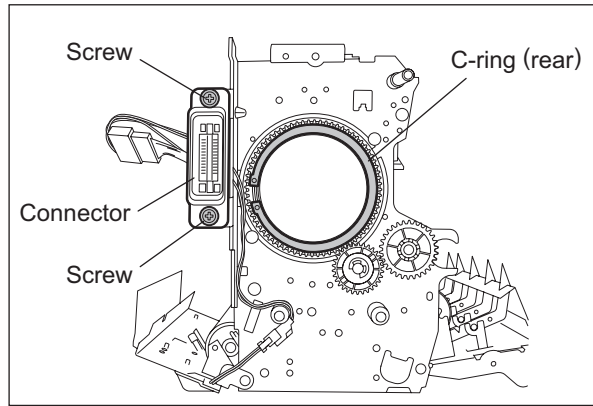

Fig. 13-37

- (10) Remove 1 E-ring and take off the gear and one-way clutch.
- (11) Remove 2 screws and take off the bearing (rear).

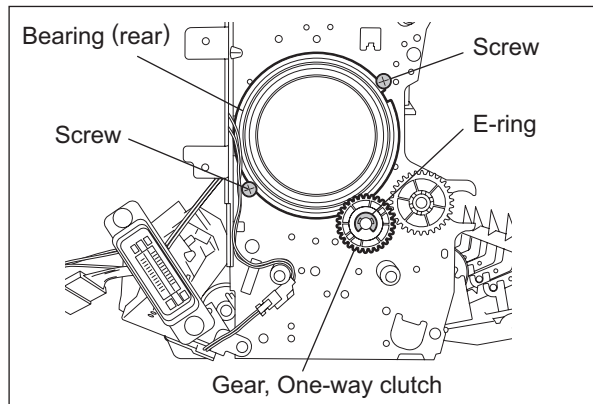

Fig. 13-38

- (12) Remove 1 C-ring (front).

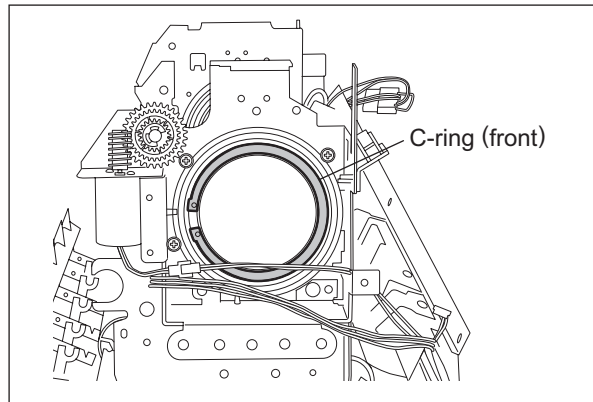

Fig. 13-39

- (13) Take off the fuser roller covering it with paper and such not to make scars on it.

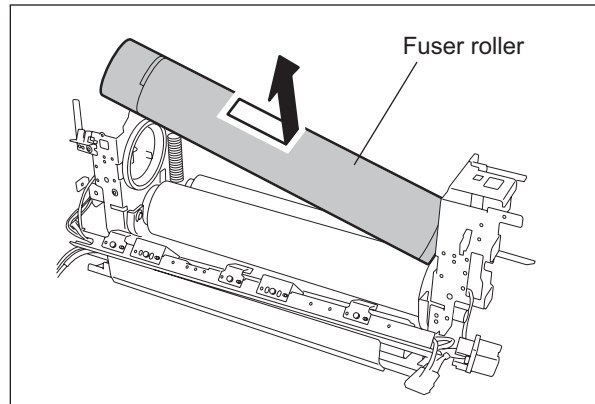

Fig. 13-40

[I] Pressure roller

- (1) Take off the fuser roller
(P.13-25 "[H] Fuser roller").
- (2) Take off the pressure roller with its bearing.
- (3) Remove 2 bearings and 2 collars from the pressure roller.

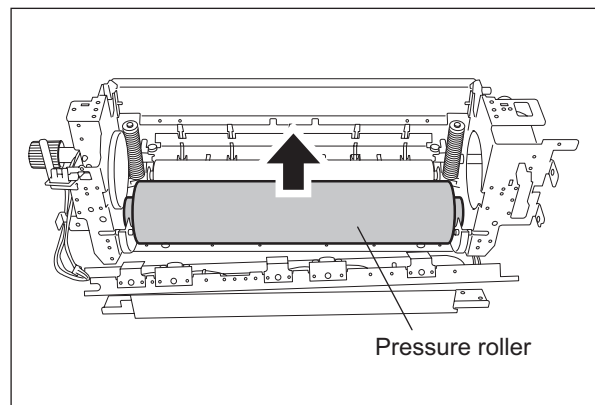

Fig. 13-41

[J] Web detection sensor (S8)

- (1) Take off the fuser unit
(P.13-17 "[B] Fuser unit").
- (2) Take off the cleaning web unit
(P.13-18 "[C] Cleaning web unit / Cleaning web").
- (3) Take off the fuser unit front cover.
- (4) Disconnect 1 connector and remove 1 screw to take off the web detection sensor with its bracket.
- (5) Release the latch of the sensor to take off the web detection sensor.

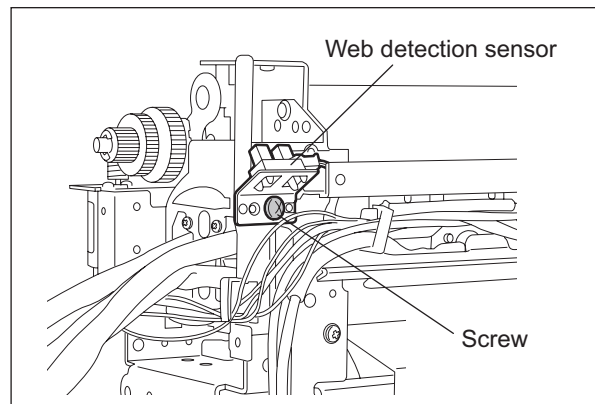

Fig. 13-42

[K] Web motor (M4) / Fuser transport sensor (S9)

- (1) Take off the fuser unit
(☞ P.13-17 "[B] Fuser unit").
- (2) Take off the cleaning web unit /
(☞ P.13-18 "[C] Cleaning web unit /
Cleaning web").
- (3) Remove 2 screws to take off the fuser unit
front cover.

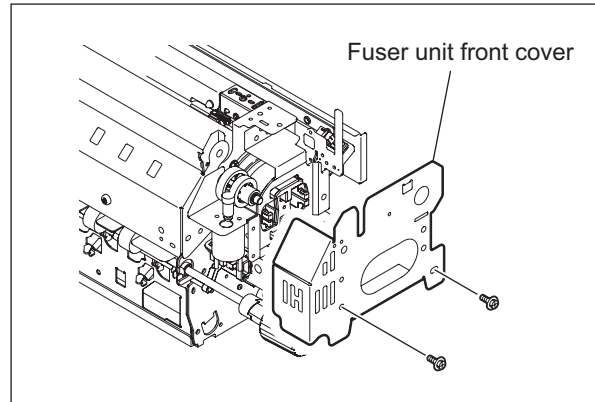

Fig. 13-43

- (4) Remove 2 screws and open the lower
separation finger unit.

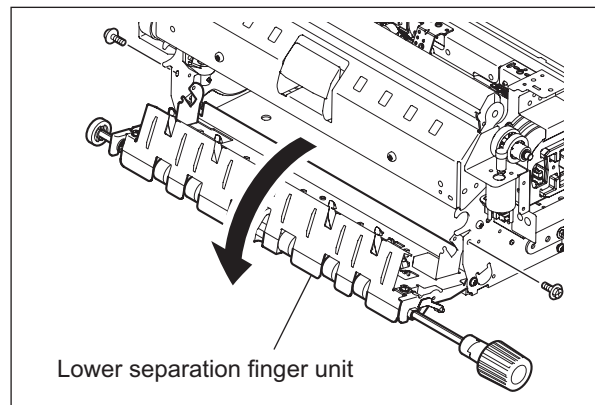

Fig. 13-44

- (5) Release the harness from the harness end-
holder and then disconnect 1 connector.
- (6) Remove 2 screws and take off the web
motor.

Note:

Pay attention to the size (length) of the
screws. If incorrect ones are used, the motor
could be damaged.

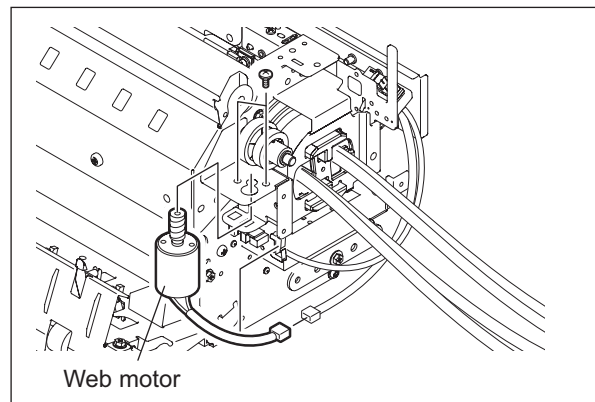

Fig. 13-45

- (7) Disconnect 1 connector to take off the fuser transport sensor.

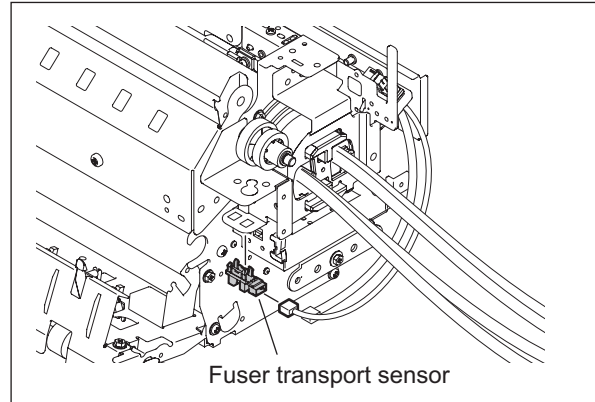

Fig. 13-46

[L] Pressure roller thermistor (THM4)

- (1) Take off the fuser unit (P.13-17 "[B] Fuser unit").
- (2) Disconnect 1 connector of the pressure roller thermistor.
- (3) Remove 2 screws to take off the lower entrance guide.
- (4) Remove 1 screw to take off the harness cover.
- (5) Remove 1 screw to take off the pressure roller thermistor.

Notes:

1. Use tightening torques of 0.4-0.6 N·m to prevent the thermistors from damage.
2. Be sure that the thermistor is contacting with the pressure roller when it has been installed.

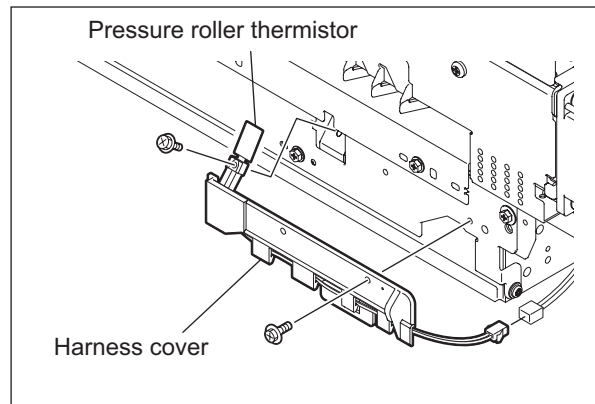

Fig. 13-47

14. EXIT/REVERSE SECTION

14.1 General Description

This equipment conducts a paper reverse operation when printing more than 2 sheet of paper or carrying out a duplex printing. Its reversing device once transports the paper from the fuser unit to the reverse path where the paper is switched back and reversed, and then transports it to the exit roller or transfer section.

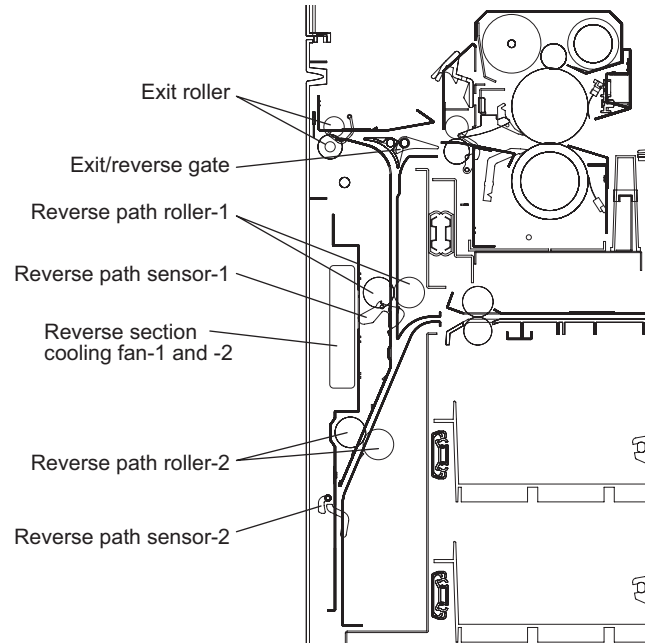

Fig. 14-1

14.2 Functions

1. Exit/reverse gate
This gate switches the paper from the fuser unit in the direction of the exit roller or reverse path. This is operated by the gate solenoid (SOL2).
2. Exit roller
The exit roller exits the paper from the fuser unit to the outside of the equipment. This is driven by the exit motor (M18).
3. Reverse path rollers
The path roller feeds the paper and switches back at the reverse path. This is driven by the reverse motor (M19) and switches the feeding speed to "high" after the trailing edge of paper goes through the fuser transport sensor (S9).
4. Reverse section cooling fan-1 and -2 (M24, M25)
These fans are equipped to cool down the reverse section.
5. Reverse sensor-1 and -2 (S23, S24)
These sensors detect the state of paper feeding.

14.3 Driving of Exit/Reverse section

The paper feeding roller in the exit/reverse section is driven by the following mechanism.

- Exit motor (G19) → Gears (G21, G20, G19) → Exit roller
- Reverse motor (T21) → Timing belt and Pulleys (T23, T23) → Reverse path roller

14.4 Operation

The paper from the fuser unit is transported to the reverse path by the exit/reverse gate, which is usually directed toward the reverse path and switched by the gate solenoid (SOL2) only when the reverse operation is not carried out.

When the trailing edge of the paper has passed through the fuser transport sensor (S9), the paper transport speed at the reverse path is switched to a high one and switched back in a specified time after that. The paper is transported to the exit roller with keeping the high speed and discharged to the outside of the equipment. When carrying out a duplex printing, the paper switched back at the reverse path is transported to the horizontal transport section, which is under the transfer/transport unit and switches the paper transport speed to a normal one at this time, and it is again transported to the transfer section and fused there. Then, after the duplex paper has passed through the fuser unit and the exit/reverse gate has been switched, it is discharged to the outside of the equipment by the exit roller without being transported to the reverse path.

- 3 sheets × 1 copy Single-sided printing operation (A4/LT)

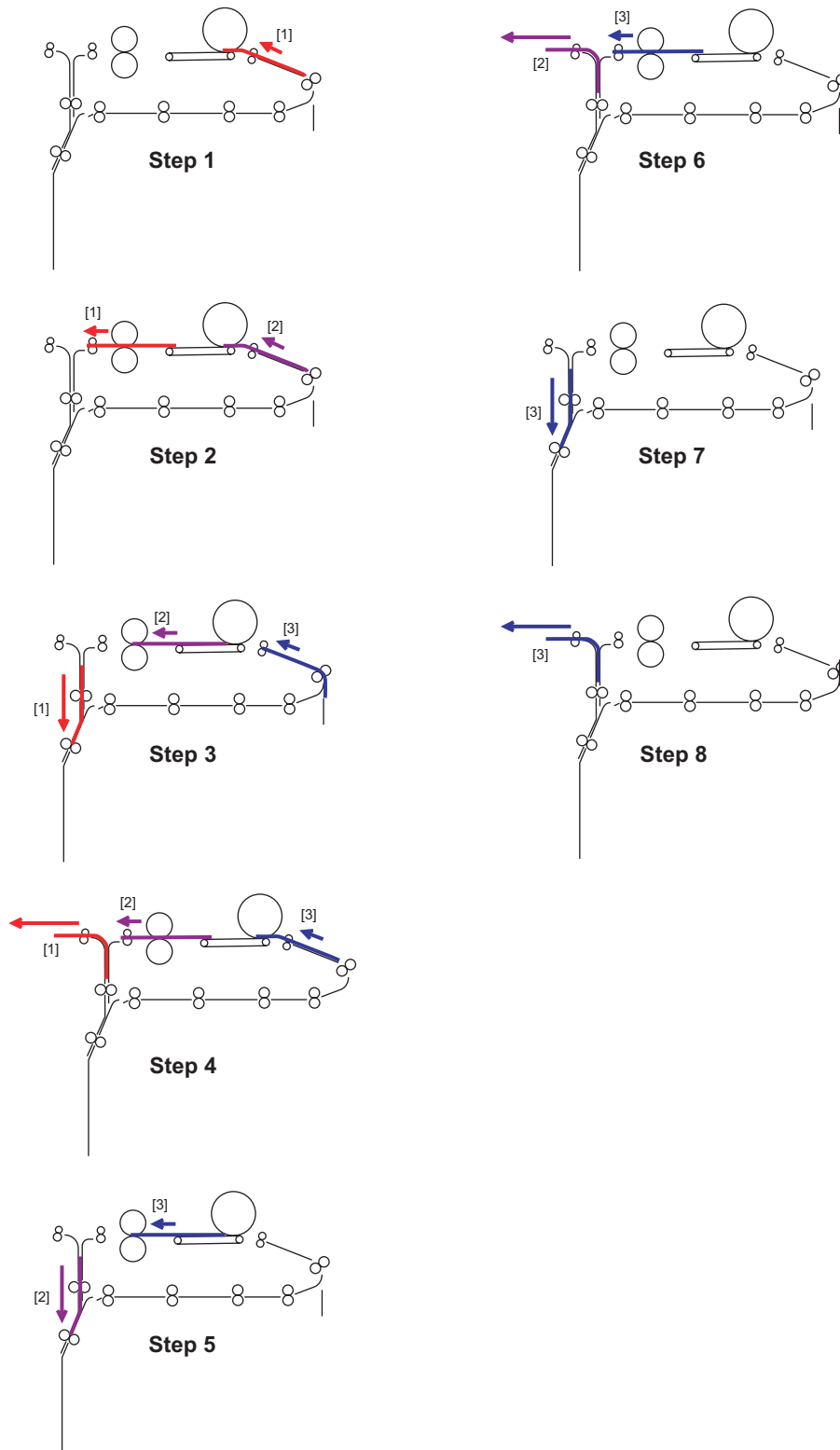

Fig. 14-2

- 5 sheets × 1 copy Duplex printing operation (A4/LT)

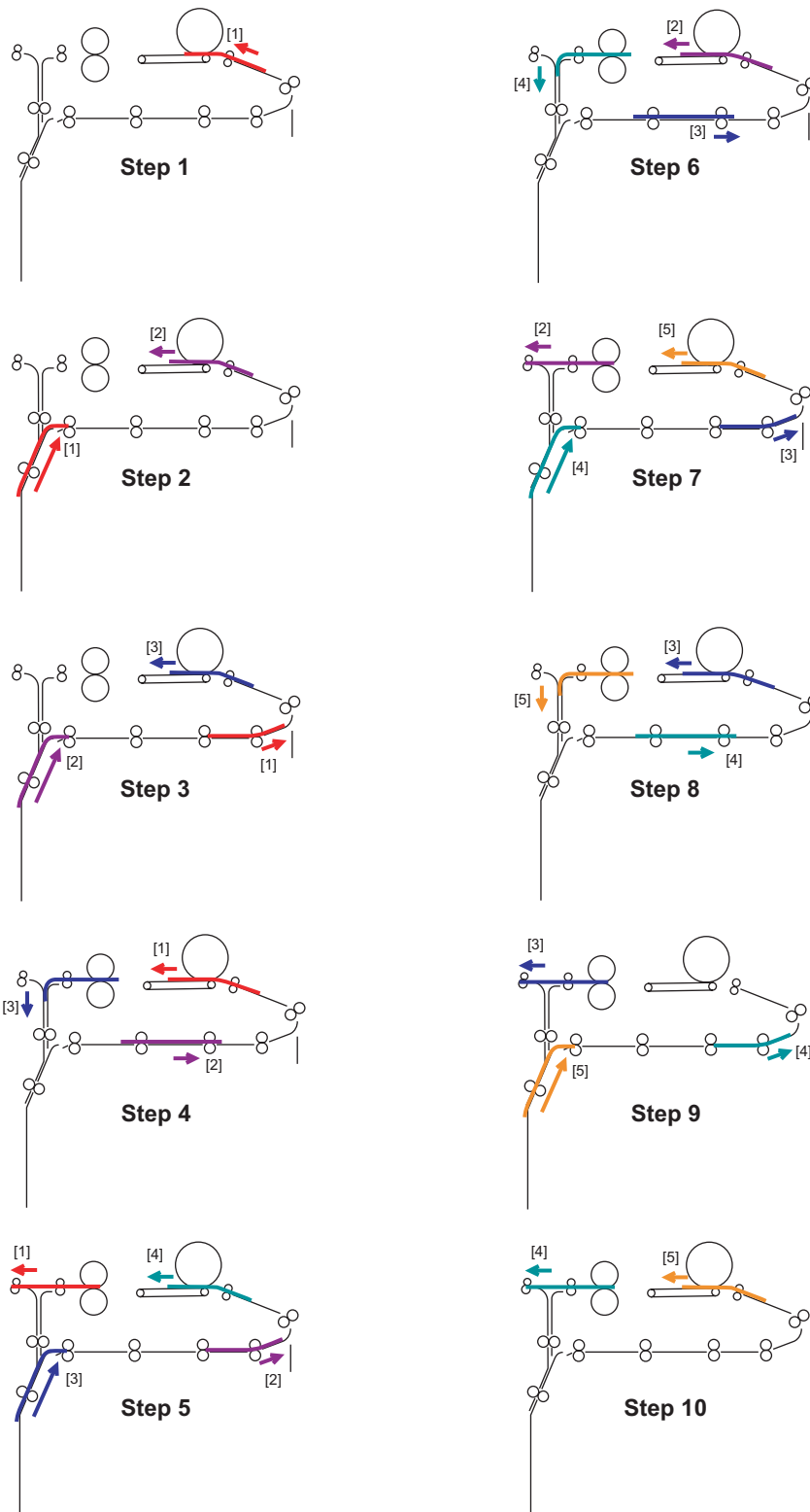

Fig. 14-3

- 3 sheets × 1 copy Single-sided printing operation (A3/LD/B4/LG/A4-R/LT-R)

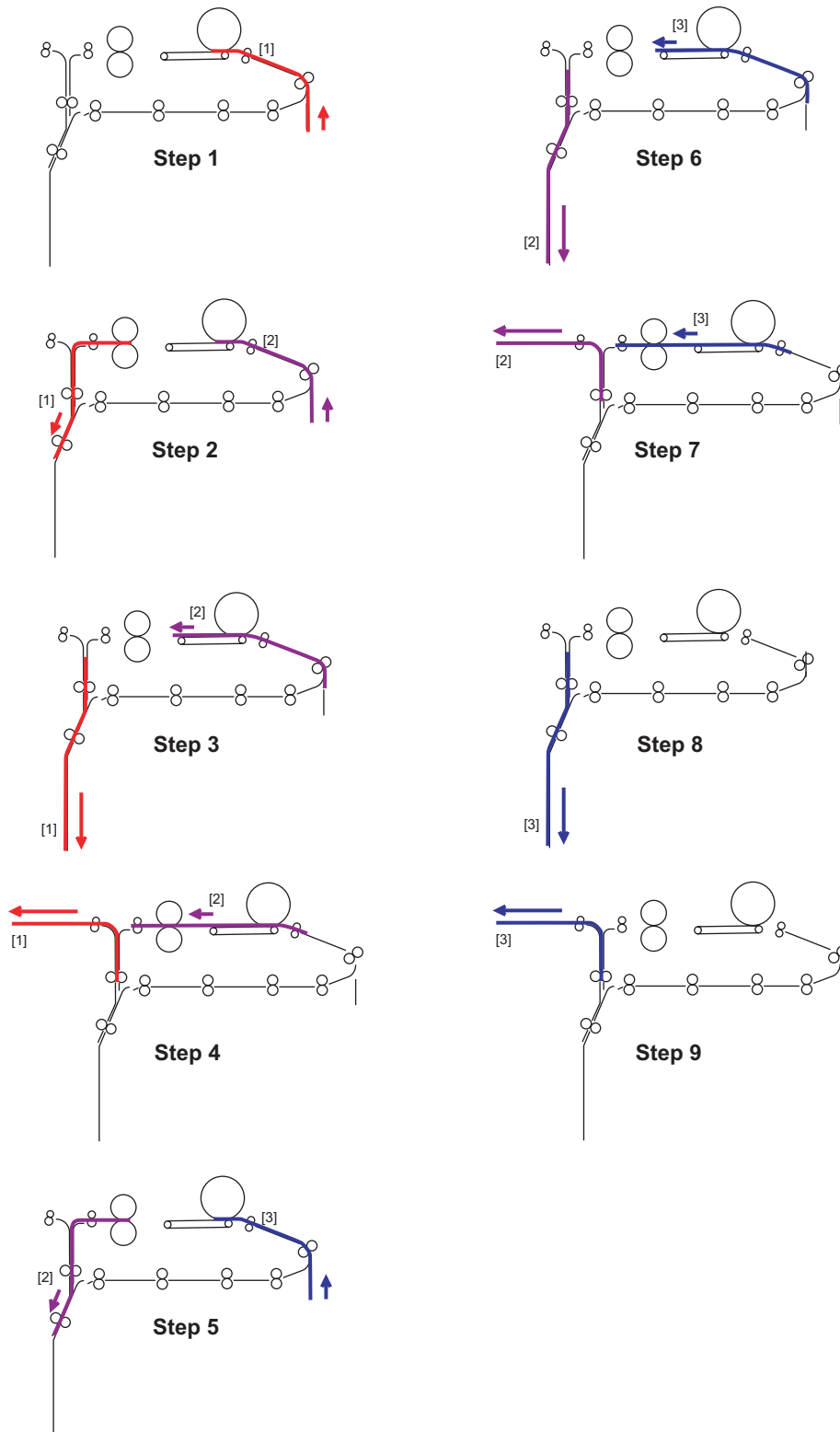

Fig. 14-4

- 4 sheets × 1 copy Duplex printing operation (A3/LD/B4/LG/A4-R/LT-R)

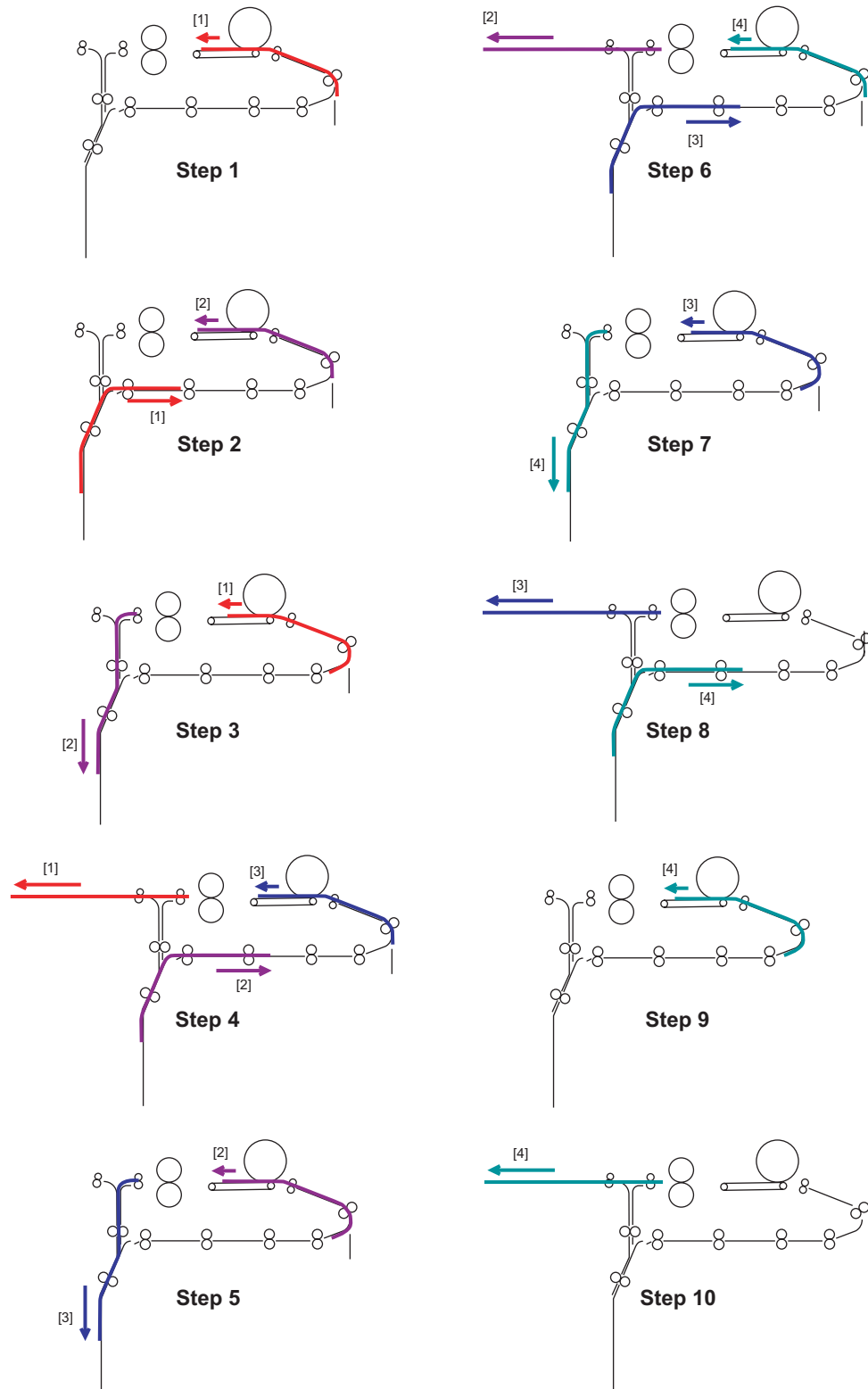

Fig. 14-5

14.5 Exit motor control circuit

The exit motor is a stepping motor driven by the control signal output from the PFC CPU on the LGC board and rotates the exit roller.

The PFC CPU outputs each phase signal (EXTMA-0, EXTMB-0, EXTMC-0, EXTMD-0) to the motor driver. The motor driver converts this phase signal into a +24 V pulse signal (EXTMA-0A, EXTMB-0A, EXTMC-0A, EXTMD-0A) and outputs it to the motor. Also, the rotation speed of the motor can be switched by changing the output timing of each pulse signal.

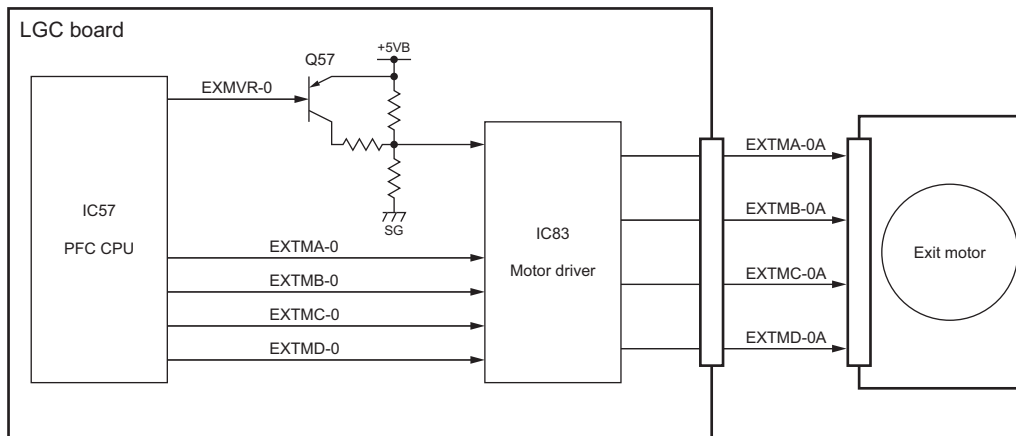

Fig. 14-6

Exit motor drive signal

Signal		Motor status
EXTMA-0 EXTMB-0 EXTMC-0 EXTMD-0	EXMVR-0	
Pulse signal	L	Rotation when accelerating/decelerating
	H	Rotation at a constant speed

14.6 Reverse motor control circuit

The reverse motor is a stepping motor driven by the control signal output from the PFC CPU on the LGC board and rotates the reverse motor-1 and -2.

The reverse motor is driven by the pulse signal (MTMA-0, MTMB-0, MTMAB-0, MTMBB-0) output from the driver IC. These pulse signals are formed based on the reference clock signal (REVMC-0) and output only when the enable signal (REVME-0) is L level. Also, the rotational speed of the motor is switched by changing the frequency of the reference clock signal (REVMC-0). The rotation direction can be switched by the motor rotation direction switch signal (REVCW-0).

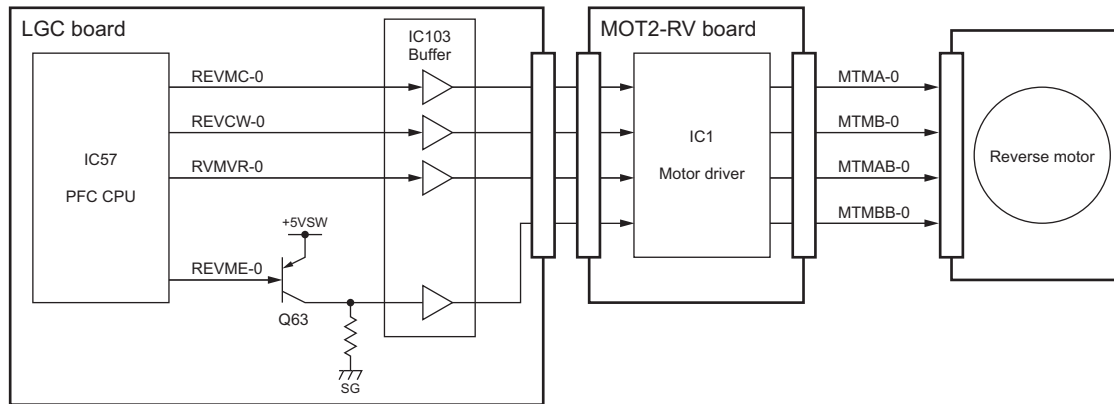



Fig. 14-7

Reverse motor drive signal

Signal				Motor status
REVMC-0	REVME-0	RVMVR-0	REVCW-0	
Pulse signal	L	L	L	Forward rotation when accelerating/ decelerating
	L	L	H	Reverse rotation when accelerating/ decelerating
	L	H	L	Forward rotation at a constant speed
	L	H	H	Reverse rotation at a constant speed
-	H	-	-	Stop

14.7 Disassembly and Replacement

[A] Exit/Reverse unit

- (1) Take off the left lower cover (= exit cover)
( P.2-44 "[J] Left lower cover (Exit cover)").
- (2) Open the exit/reverse unit and remove 1 screw.

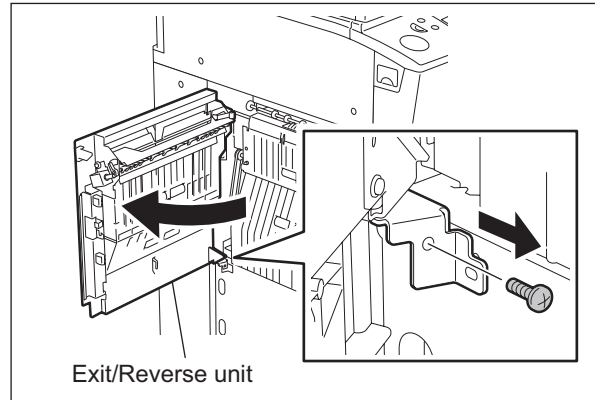

Fig. 14-8

- (3) Disconnect 1 connector. Then take off the exit/reverse unit by lifting it up.

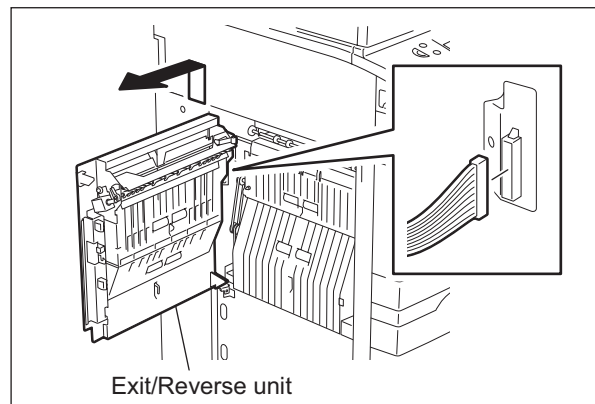



Fig. 14-9

[B] Reverse section cooling fan-1 [M24] / Reverse section cooling fan-2 [M25]

- (1) Take off the left lower cover (= exit cover)
( P.2-44 "[J] Left lower cover (Exit cover)").
- (2) Disconnect 1 connector, remove 2 screws and then take off the reverse section cooling fan-1.
- (3) Disconnect 1 connector, remove 2 screws and then take off the reverse section cooling fan-2.

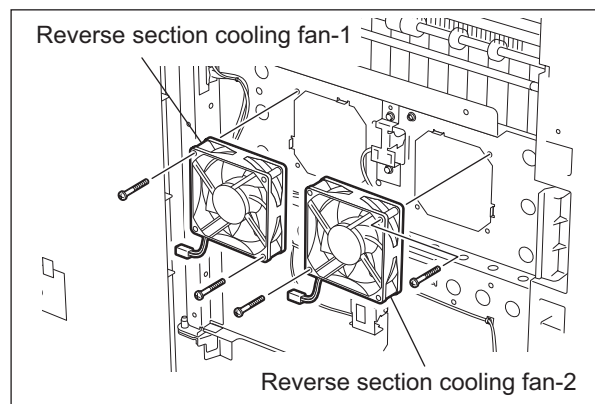

Fig. 14-10

[C] Exit sensor [S22]

- (1) Take off the left lower cover (= exit cover)
(☞ P.2-44 "[J] Left lower cover (Exit cover)").
- (2) Disconnect 1 connector, remove 1 screw and then take off the sensor with its bracket.

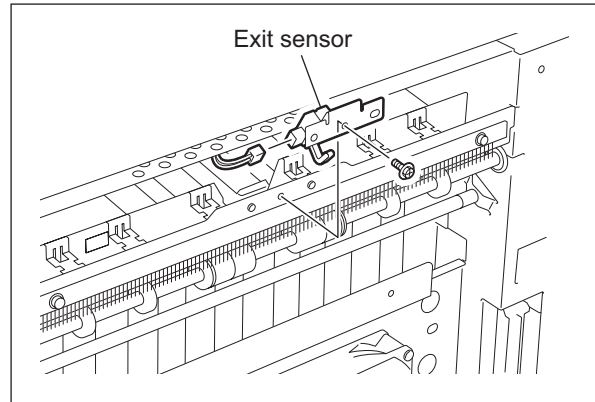

Fig. 14-11

- (3) Release the latch to take off the exit sensor.

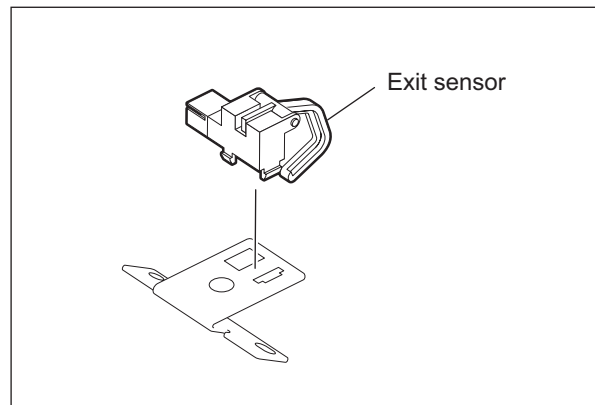

Fig. 14-12

[D] Reverse sensor-1 [S23] / Reverse sensor-2 [S24]

- (1) Take off the left lower cover (= exit cover)
(☞ P.2-44 "[J] Left lower cover (Exit cover)").
- (2) Disconnect 1 connector, remove 2 screws and then take off the reverse sensor-1.
- (3) Disconnect 1 connector, remove 1 screw and then take off the reverse sensor-2.

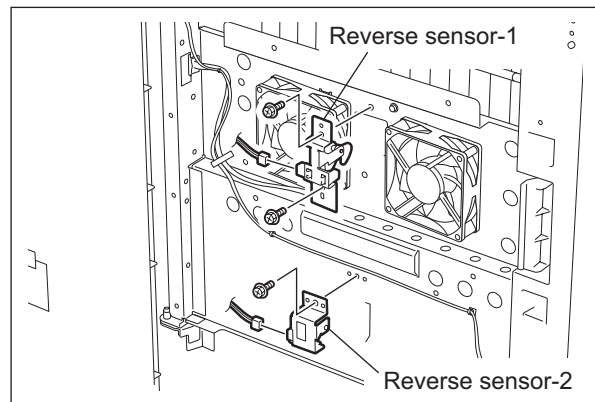

Fig. 14-13

[E] Exit cover switch [SW5]

- (1) Take off the left lower cover (= exit cover) (P.2-44 "[J] Left lower cover (Exit cover)").
- (2) Open the exit/reverse unit. Then disconnect the connector and release the latch to take off the exit cover switch.

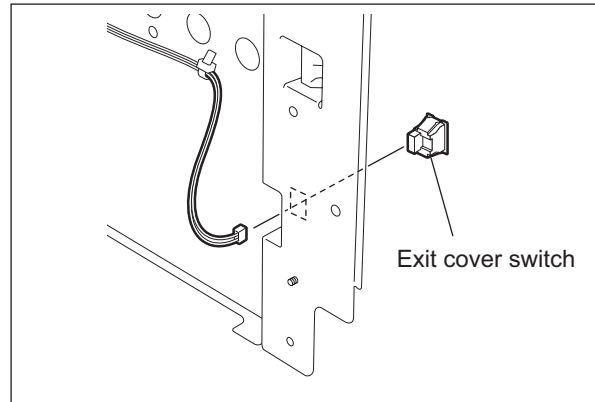

Fig. 14-14

[F] Gate solenoid [SOL2]

- (1) Take off the left lower cover (= exit cover) (P.2-44 "[J] Left lower cover (Exit cover)").
- (2) Open the exit/reverse unit. Then disconnect 1 connector, release the clamp and remove 3 screws to take off the gate solenoid.

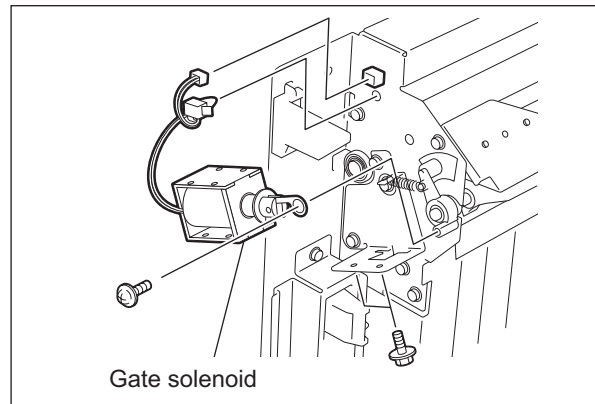

Fig. 14-15

Note:

The solenoid is normally screwed at the position A shown in the figure at right. However, the position of the solenoid can be adjusted by moving this screw to the position B when the flap valve of the solenoid is not pulled enough.

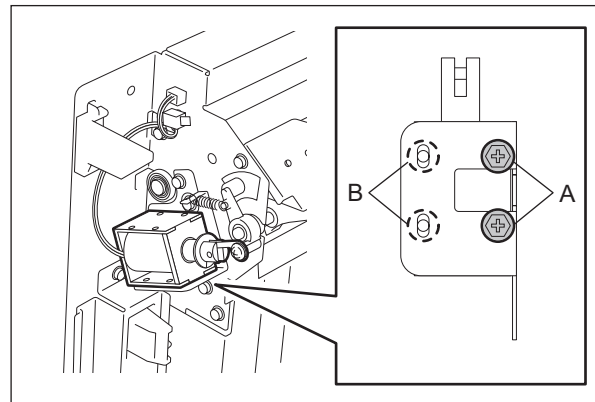



Fig. 14-16

[G] Exit roller

- (1) Take off the exit/reverse unit
( P.14-9 "[A] Exit/Reverse unit").
- (2) Remove the E-ring, gear and pin.
- (3) Remove 2 E-rings and take off the exit roller by sliding 2 bearings to the inside.

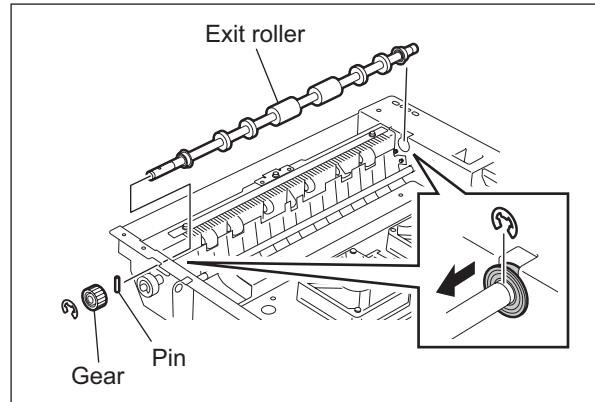



Fig. 14-17

[H] Reverse section driving unit / Reverse motor driving PC board (MOT2-RV board)

- (1) Take off the exit/reverse unit
( P.14-9 "[A] Exit/Reverse unit").
- (2) Disconnect 1 connector, remove 6 screws and then take off the reverse section driving unit.

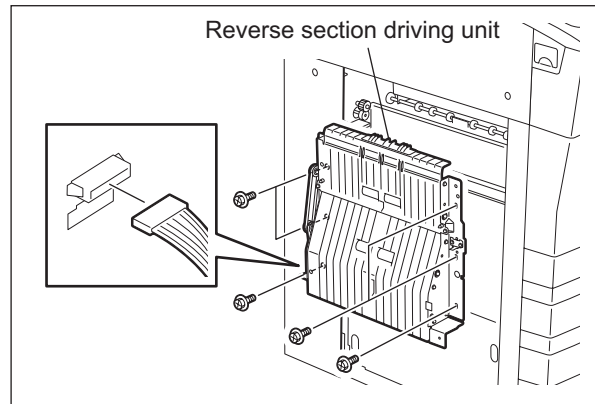

Fig. 14-18

- (3) Release 4 locking supports to take off the MOT2-RV board.

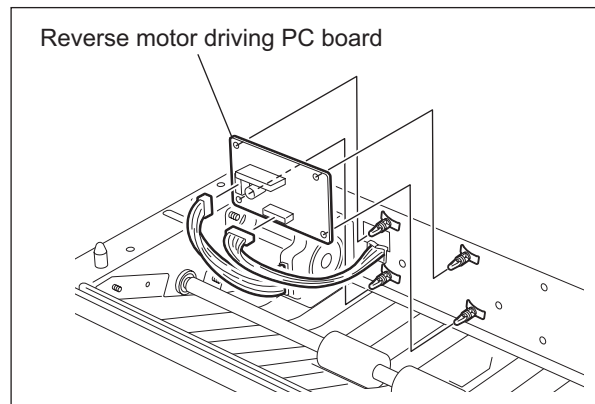

Fig. 14-19

[I] Reverse motor [M19]

- (1) Take off the reverse section driving unit (P.14-12 "[H] Reverse section driving unit / Reverse motor driving PC board (MOT2-RV board)").
- (2) Disconnect 1 connector, remove 2 screws and then take off the reverse motor.

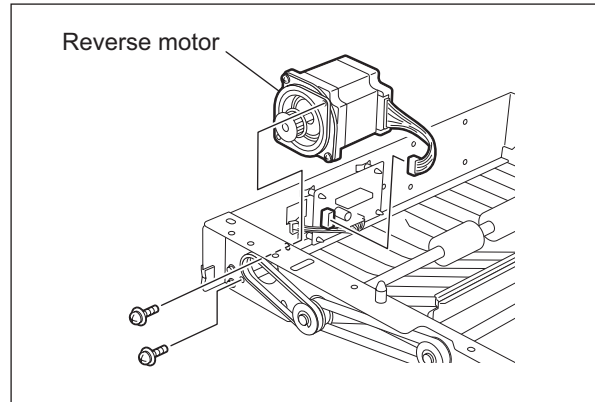

Fig. 14-20

[J] Reverse roller-1 / Reverse roller-2

- (1) Take off the reverse section driving unit (P.14-12 "[H] Reverse section driving unit / Reverse motor driving PC board (MOT2-RV board)").
- (2) Take off the reverse motor (P.14-13 "[I] Reverse motor [M19]").
- (3) Remove 2 E-rings, 2 gears and 2 belts.

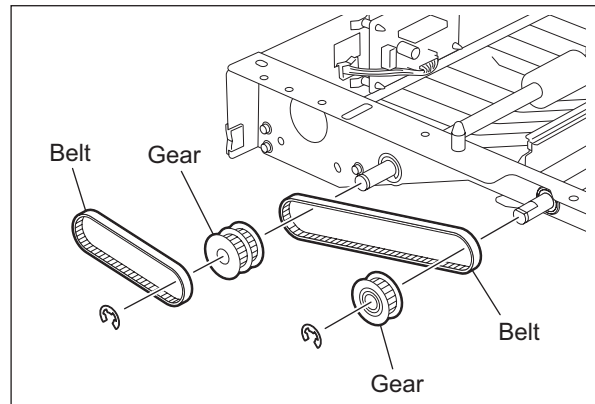

Fig. 14-21

- (4) Remove 2 E-rings and 2 bearings to take off the reverse roller-1.
- (5) Remove 2 E-rings and 2 bearings to take off the reverse roller-2.

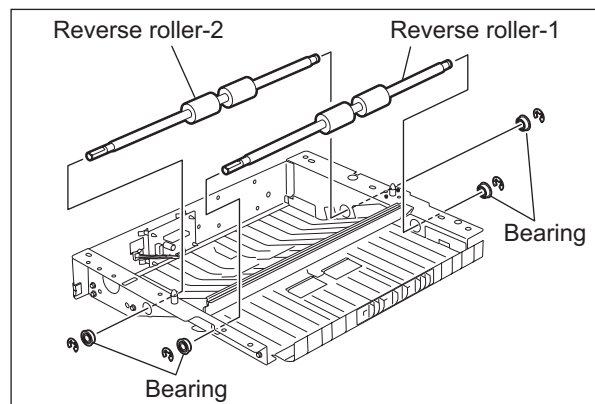

Fig. 14-22

[K] Exit motor [M18]

- (1) Take off the reverse section driving unit (P.14-12 "[H] Reverse section driving unit / Reverse motor driving PC board (MOT2-RV board)").
- (2) Take off the rear cover (P.2-45 "[L] Rear cover").
- (3) Take off the LGC board cover and disconnect 1 connector.
- (4) Remove 2 screws and take off the exit motor.

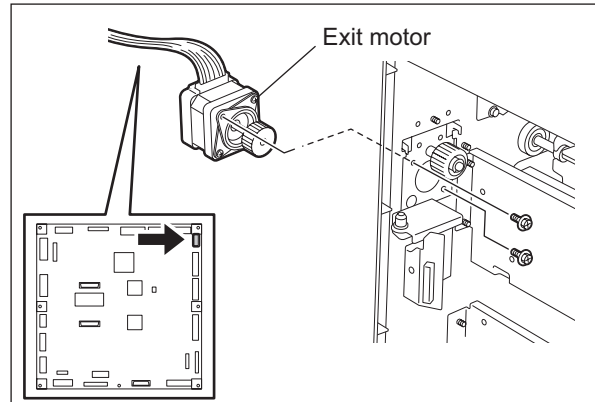

Fig. 14-23

[L] O-ring

When installing the receiving tray, add the O-rings (service parts) to the exit roller in order to improve the paper stacking condition.

- (1) Remove 6 screws and take off the left lower cover (exit cover). (P.2-44 "[J] Left lower cover (Exit cover)")
- (2) Remove 2 E-rings and move the 2 bearings toward the inside.

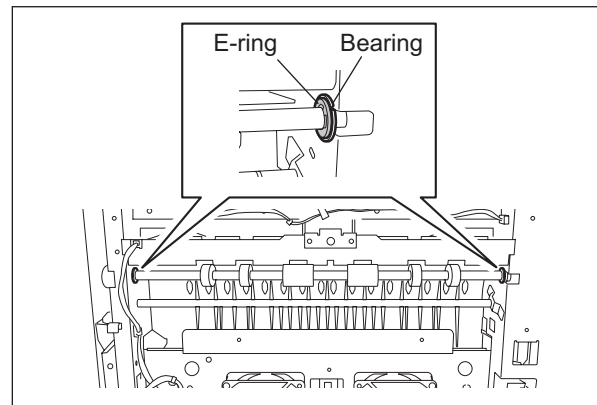

Fig. 14-24

- (3) Move the exit roller to the near side and install 2 O-rings to the grooves of the exit roller.

Note:

O-ring: Refer to the parts list for the parts number and so on.

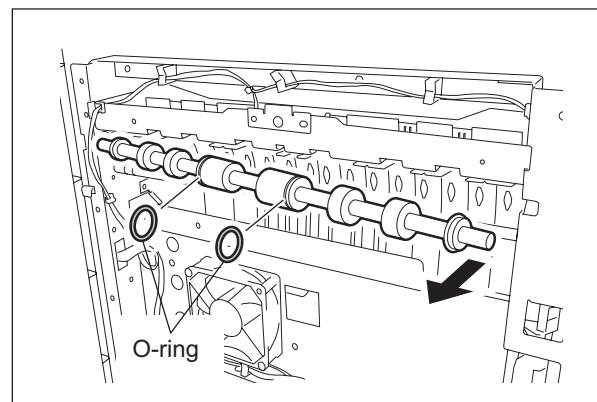

Fig. 14-25

15. REVERSING AUTOMATIC DOCUMENT FEEDER (RADF)

15.1 General Description

The Reversing Automatic Document Feeder (RADF) transports original sheets to the RADF original glass and then to the original exit tray after they have been scanned. In scanning double-sided originals, the original is reversed in the exit paper path exclusive to original reversing after the back side has been scanned and then it exits. Therefore the next original can be scanned without waiting for the previous one to exit.

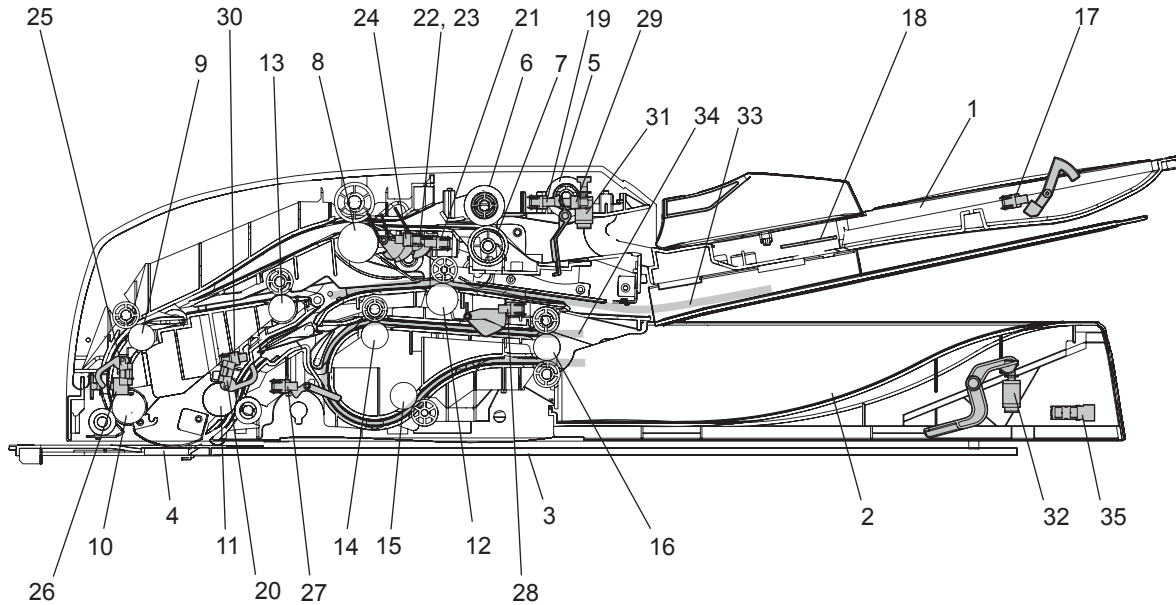

Fig. 15-1

No.	Name	No.	Name
1	Original tray	19	Original empty sensor (SR3)
2	Original exit tray	20	Original reading end sensor (SR4)
3	Original glass	21	Original registration sensor (SR5)
4	RADF original glass	22	Original width detection sensor-1 (SR6)
5	Pickup roller	23	Original width detection sensor-2 (SR7)
6	Feed roller	24	Original width detection sensor-3 (SR8)
7	Separation roller	25	Original intermediate transport sensor (SR9)
8	Original registration roller	26	Original reading start sensor (SR10)
9	Intermediate transport roller	27	Original exit/reverse sensor (SR11)
10	Reading start roller	28	Original exit sensor (SR12)
11	Reading end roller	29	Original jam access cover opening/closing sensor (SR13)
12	Reverse roller	30	Original reverse unit opening/closing sensor (SR14)
13	Reverse registration roller	31	Jam access cover opening/closing switch (SWR1)
14	Exit intermediate roller	32	RADF opening/closing switch (SWR2)
15	Exit/reverse roller	33	Reverse paper path
16	Exit roller	34	Exit paper path
17	Original tray sensor (SR1)	35	RADF opening/closing sensor (SR15)
18	Original tray width sensor (SR2)		

15.2 Functions

1. Pickup roller
This roller pulls out the original on the original tray and transports it to the feed roller.
2. Feed roller
This roller is placed against the separation roller. It transports the original sent by the pickup roller.
3. Separation roller
This roller is placed against the feed roller. When two originals or more are transported from the pickup roller, the load of the torque limiter of the separation roller is heavier than the frictional force between the sheets. As a result, the separation roller is stopped and the lower paper is not advanced any further.
4. Registration roller
This roller aligns the sheets sent by the transport roller.
5. Intermediate transport roller / Reading start roller
These rollers transport the original to the RADF original glass.
6. Reading end roller
This roller transports the original scanned at the RADF original glass to the reverse paper path or the exit paper path.
7. Reverse roller
This roller switches back the original during duplex scanning.
8. Reverse registration roller
This roller aligns the original switched back by the reverse roller and transports it to the intermediate transport roller.
9. Exit intermediate roller
This roller transports the original sent from the reading end roller to the exit path and switches it back.
10. Exit/reverse roller
This roller transports the original reversed in the exit path to the exit roller.
11. Exit roller
This roller transports the original to the original exit tray.

15.3 Description of Operation

15.3.1 Paper path

In scanning double-sided originals, an original is transported to the reverse paper path after the front side has been scanned and it is switched back with the reverse roller so that it is reversed. After the back side of the original has been scanned, it is transported to the exit paper path, switched back with the exit intermediate roller, and it exits on the original exit tray so that the originals are aligned in the order.

1. Single-sided original

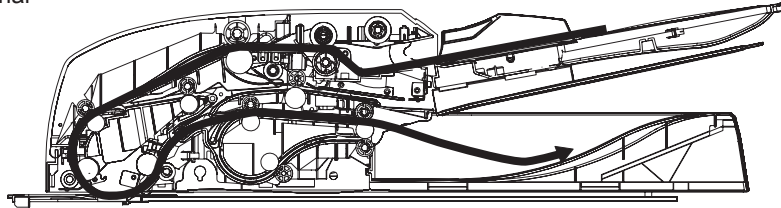

2. Double-sided original

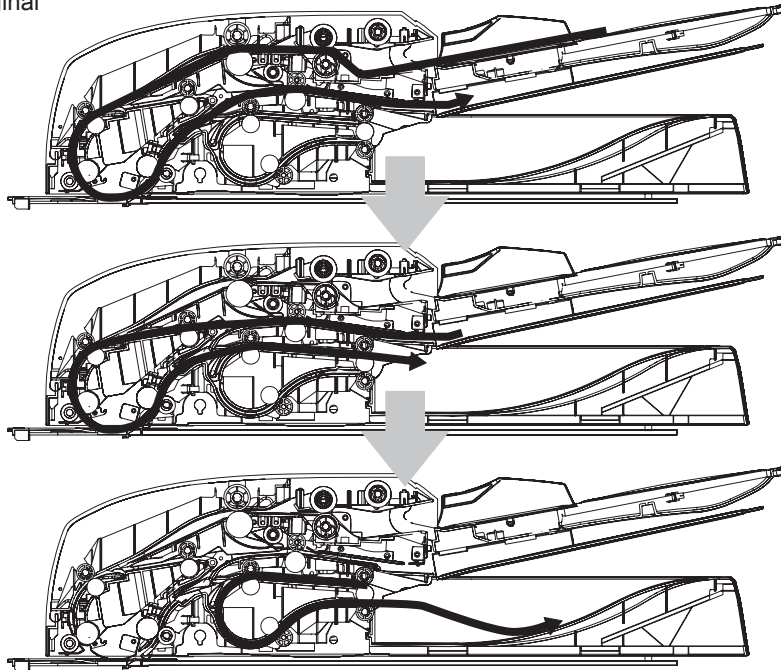

Fig. 15-2

15.3.2 Drive

4 stepping motors are used for driving the Reversing Automatic Document Feeder. Each motor rotates in order to drive the roller.

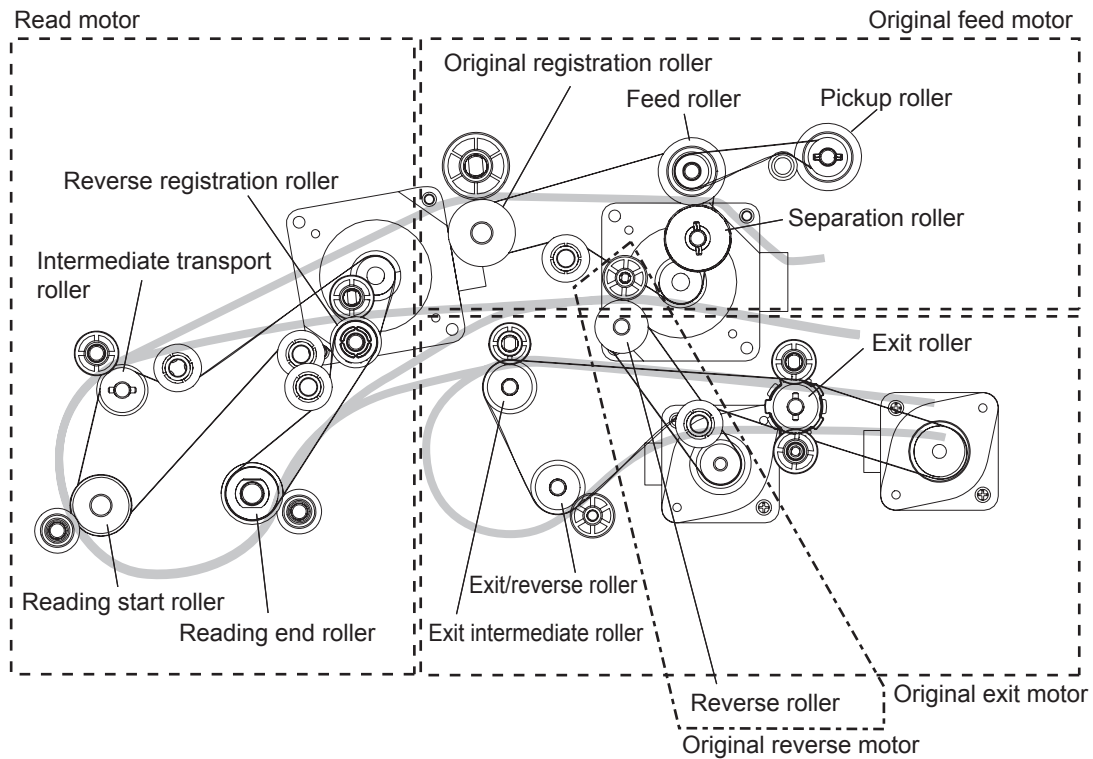

Fig. 15-3

Motor	Rotation	Roller	Remarks
Original feed motor (MR1)	Normal rotation	Pickup roller Feed roller	Feeding
	Reverse rotation	Registration roller	
Read motor (MR2)	Normal rotation	Intermediate transport roller Reading start roller Reading end roller Reverse registration roller	
Original reverse motor (MR3)	Normal rotation / Reverse rotation	Reverse roller	
Original exit motor (MR4)	Normal rotation / Reverse rotation	Exit intermediate roller Exit/reverse roller Exit roller	Normal rotation: Front side exiting Reverse rotation: Backside exiting

15.3.3 Original size detection

The original tray width sensor, original registration sensor, and original width detection sensors-1, -2 and -3 work in combination to detect the size of originals.

[1] Outline

When an original is placed on the original tray, the width of the original is detected by the positions of the original width guides. Then the original width detection sensors -1, -2 and -3 and the original registration sensor detect the size of the original being transported. Based on the detection result of these sensors, the size of the original is finally determined.

[2] Original tray width sensor

The original tray width sensor detects the width of an original placed on the original tray.

It is detected by the brush attached to the rack moving on the original tray width sensor, which is a board with the different length of the patterns written.

This brush is moved as the original width guide is moved. Signals (TWID0S, TWID1S, TWID2S) are opened and shorted to SG by this movement.

The combination of these short (= low level) and open (= high level) can determine the width of the original.

Sizes detectable in combination of these open and short of the signals are as follows:

TWID2S	TWID1S	TWID0S	Original width size (LT series)	Original width size (A4 series)
H	H	L	-	B5-R
H	L	H	ST-R	A5-R
H	L	L	LD / LT	A3 / A4
L	H	L	8.5x8.5 / LT-R / LG / 13"LG	A4-R / FOLIO
L	L	L	COMPUTER	B4 / B5

H (= high level): Open L (= low level): Short

[3] Original width detection sensors-1, -2 and -3 / Original registration sensor

The size of the original is determined by the detection performed in combination of the original width detection sensors-1, -2 and -3 and the original registration sensor, as well as the detection performed by the original tray width sensor.

Sizes detectable in combination of these sensors are as follows:

A4series: (08-201: 0 or 2)

Original tray width sensor	Original tray sensor	Original registration sensor	Original width detection sensor-1	Original width detection sensor-2	Original width detection sensor-3	Size determined
-	-	ON	ON	ON	ON	A3
-	-		ON	ON	OFF	LD
B5/B4	-		ON	OFF	OFF	B4
-	ON		ON	OFF	OFF	FOLIO
A4/A3	OFF		OFF	OFF	OFF	A4-R
-	-		OFF	OFF	OFF	B5-R
-	-	OFF	ON	ON	ON	A4
-	-		ON	ON	OFF	LT
-	-		ON	OFF	OFF	B5
-	-		OFF	OFF	OFF	A5-R

A4 series (width sizes mixed at A3 / A4 standard)

Original tray width sensor	Original tray sensor	Original registration sensor	Original width detection sensor-1	Original width detection sensor-2	Original width detection sensor-3	Size determined
A3/A4	-	ON	ON	ON	-	A3
	-		ON	OFF	-	B4
	-		OFF	OFF	-	A4-R/FOLIO
	-	OFF	ON	ON	-	A4
	-		ON	OFF	-	B5

A4 series (width sizes mixed at B4 / B5 standard)

Original tray width sensor	Original tray sensor	Original registration sensor	Original width detection sensor-1	Original width detection sensor-2	Original width detection sensor-3	Size determined
B4/B5	-	ON	ON	OFF	-	B4
	-		OFF	OFF	-	A4-R/FOLIO
	-	OFF	ON	OFF	-	B5
	-		OFF	OFF	-	A5-R

A4 series (width sizes mixed at A4-R standard)

Original tray width sensor	Original tray sensor	Original registration sensor	Original width detection sensor-1	Original width detection sensor-2	Original width detection sensor-3	Size determined
A4-R	-	ON	ON	OFF	-	A4-R/FOLIO
	-		OFF	OFF	-	B5-R
	-	OFF	OFF	OFF	-	A5-R

A4 series (width sizes mixed at B5-R standard)

Original tray width sensor	Original tray sensor	Original registration sensor	Original width detection sensor-1	Original width detection sensor-2	Original width detection sensor-3	Size determined
B5-R	-	ON	OFF	OFF	-	B5-R
	-	OFF	OFF	OFF	-	A5-R

LT series (08-201:1)

Original tray width sensor	Original tray sensor	Original registration sensor	Original width detection sensor-1	Original width detection sensor-2	Original width detection sensor-3	Size determined
-	-	ON	ON	ON	ON	A3
-	-		ON	ON	OFF	LD
COMP	-		ON	OFF	OFF	COMP
-	ON		ON	OFF	OFF	LG
LT-R/LG	OFF		ON	OFF	OFF	LT-R
-	-	OFF	ON	ON	ON	A4
-	-		ON	ON	OFF	LT
-	-		ON	OFF	OFF	8.5x8.5
-	-		OFF	OFF	OFF	ST-R

LT series (width sizes mixed at LD / LT standard)

Original tray width sensor	Original tray sensor	Original registration sensor	Original width detection sensor-1	Original width detection sensor-2	Original width detection sensor-3	Size determined
LD/LT	-	ON	ON	ON	-	LD
	-		ON	OFF	-	COMP
	-		OFF	OFF	-	LT-R/LG
	-	OFF	ON	ON	-	LT

LT series (width sizes mixed at COMP standard)

Original tray width sensor	Original tray sensor	Original registration sensor	Original width detection sensor-1	Original width detection sensor-2	Original width detection sensor-3	Size determined
COMP	-	ON	ON	OFF	-	COMP
	-		OFF	OFF	-	LT-R/LG
	-	OFF	OFF	OFF	-	ST-R

LT series (width sizes mixed at LG / LT-R standard)

Original tray width sensor	Original tray sensor	Original registration sensor	Original width detection sensor-1	Original width detection sensor-2	Original width detection sensor-3	Size determined
LG/LT-R	-	ON	ON	OFF	-	LT-R/LG
	-	OFF	ON	OFF	-	8.5x8.5
	-		OFF	OFF	-	ST-R

15.4 Electric Circuit Description

15.4.1 Signal block diagram

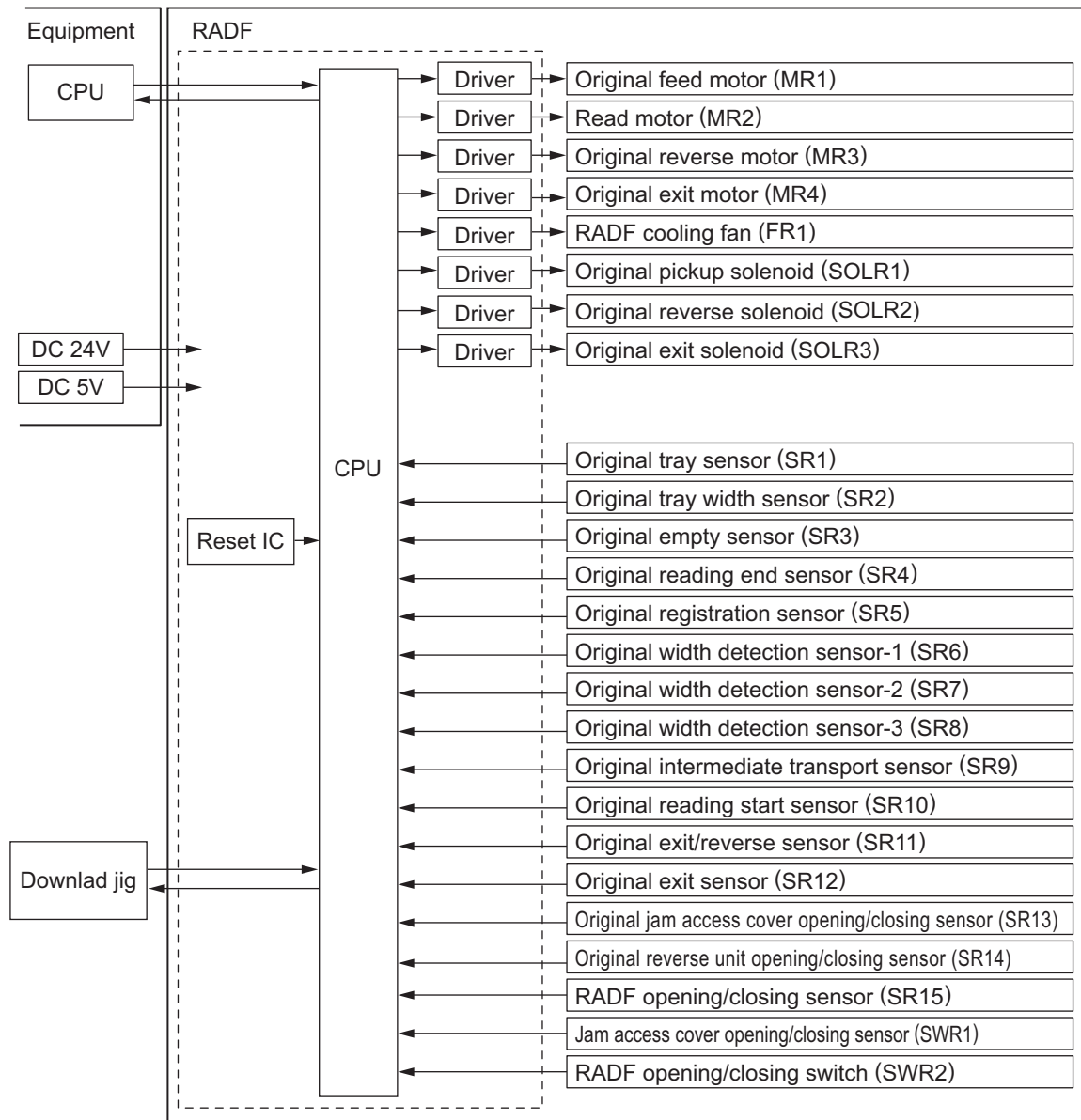

Fig. 15-4

[B] Read motor control circuit

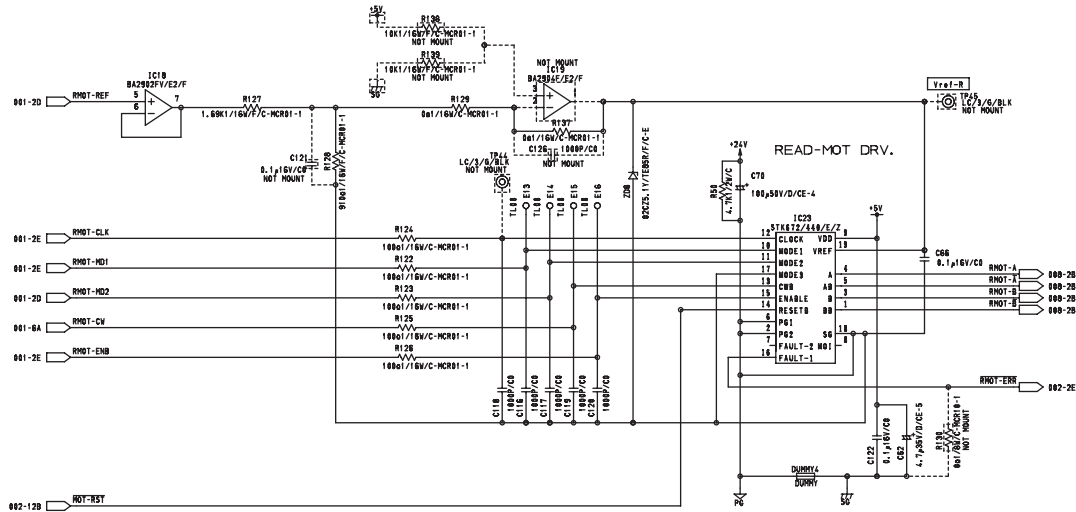

Fig. 15-6

This circuit controls the rotation/stoppage and the direction of rotation, excitation mode and motor current of the read motor. The speed and direction of the motor rotation can be controlled by inputting the drive clock signal (RMT-CLK) and rotation direction signal (RMT-CW). When the level of the enabling signal (RMT-ENB) is set to "L", the motor current is turned to OFF regardless of the state of other signals. One of the 2 phase excitation, 1-2 phase excitation, W1-2 phase excitation, 2W1-2 phase excitation and 4W1-2 phase excitation can be selected by the excitation switching signal (RMT-MD1/RMT-MD2). The edge switching signal (RMT-MD3) is used to specify the switching timing for excitation phase either from when both the rising and decay edge of the CLK input are detected or when only the rising edge is detected. The motor current value can be set discretionary by changing the level of the reference setting signal (RMT-REF).

[C] Original reverse motor control circuit

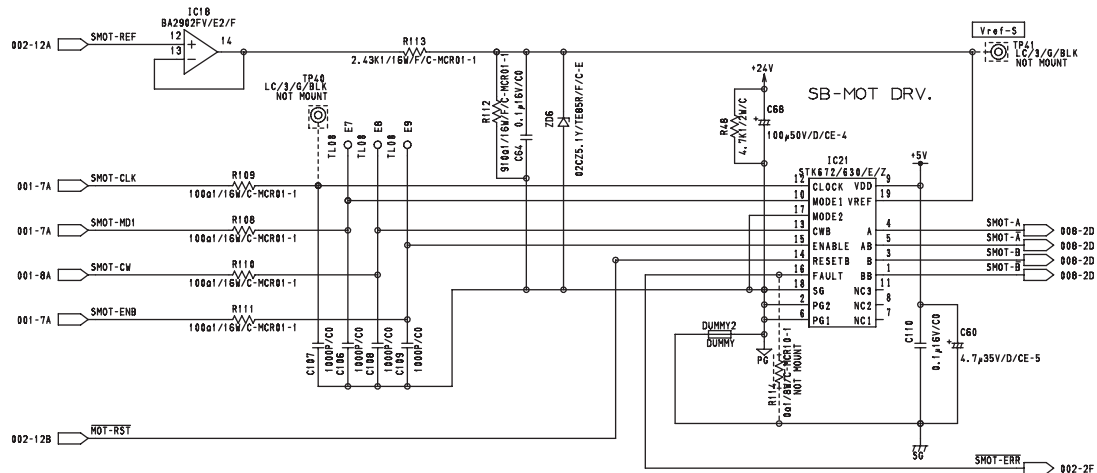

Fig. 15-7

This circuit controls the rotation/stoppage and the direction of rotation, excitation mode and motor current of the original reverse motor. The speed and direction of the motor rotation can be controlled by inputting the drive clock signal (SMOT-CLK) and rotation direction signal (SMOT-CW). When the level of the enabling signal (SMOT-ENB) is set to “L”, the motor current is turned OFF regardless of the state of other signals. Either the 2 phase excitation or 1-2 phase excitation can be selected by the excitation switching signal (SMOT-MD1). The edge switching signal (SMOT-MD2) is used to specify the switching timing for excitation phase either from when both the rising and decay edge of the CLK input are detected or when only the rising edge is detected. The motor current value can be set discretionary by changing the level of the reference setting signal (SMOT-REF).

[D] Original exit motor control circuit

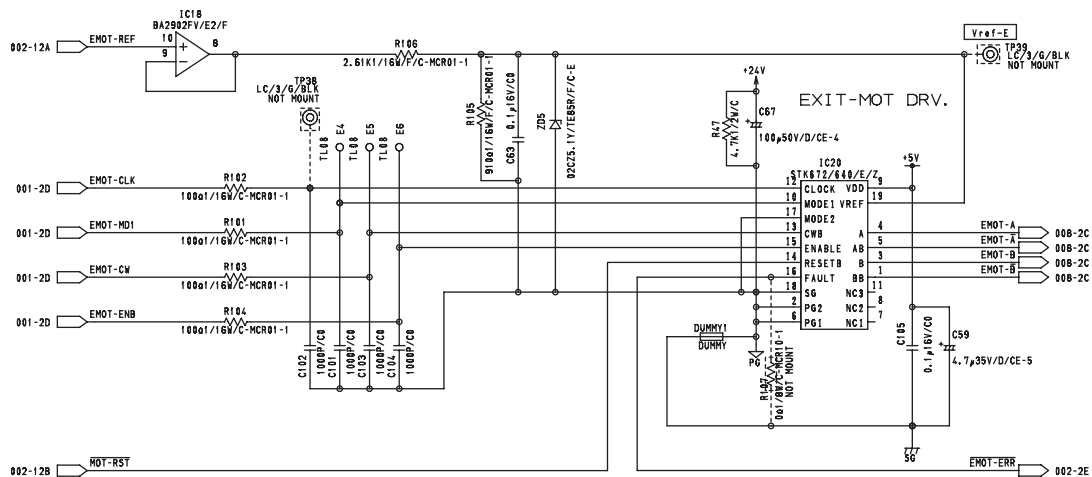

Fig. 15-8

This circuit controls the rotation/stoppage and the direction of rotation, excitation mode and motor current of the original exit motor. The speed and direction of the motor rotation can be controlled by inputting the drive clock signal (EMOT-CLK) and rotation direction signal (EMOT-CW). When the level of the enabling signal (EMOT-ENB) is set to “L”, the motor current is turned OFF regardless of the state of other signals. Either the 1-2 phase excitation or W1-2 phase excitation can be selected by the excitation switching signal (EMOT-MD1). The edge switching signal (EMOT-MD2) is used to specify the switching timing for excitation phase either from when both the rising and decay edge of the CLK input are detected or when only the rising edge is detected. The motor current value can be set discretionary by changing the level of the reference setting signal (EMOT-REF).

[E] Original pickup solenoid control circuit

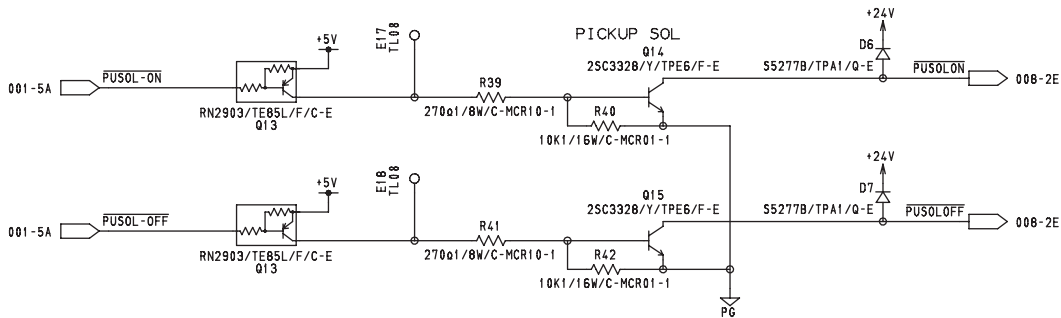

Fig. 15-9

The pickup solenoid is a two-way solenoid that can be operated both in suction and recovery, and driven by two transistors (Q14 and Q15) for each operation respectively. When the level of the PUSOL-ON signal is set to “L”, Q14 is turned ON, the power of 24V is applied to the coil for suction operation, the solenoid is turned ON, and then the pickup roller goes down. When the level of the PUSOL-ON signal is set to “L”, Q15 is turned ON, the power of 24V is applied to the coil for recovery operation, the solenoid is turned OFF, and then the pickup roller goes up.

[F] Original reverse solenoid/Original exit solenoid control circuit

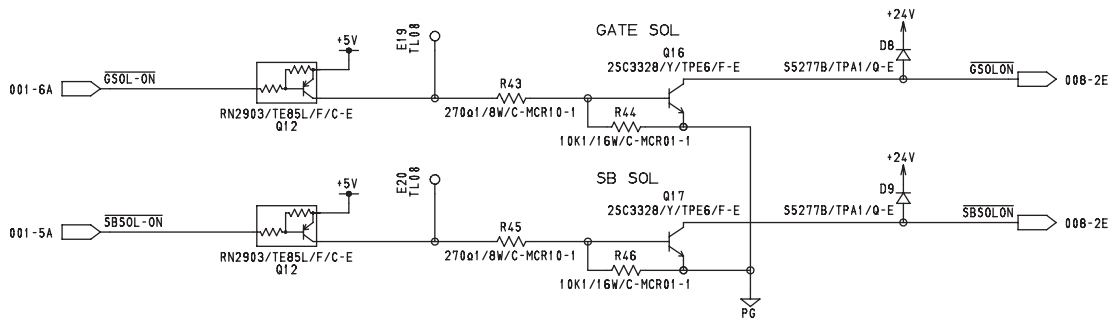

Fig. 15-10

The original reverse solenoid is a solenoid that drives the flapper to switch the path, to which originals are to be transported, to either the reverse paper path or the exit paper path when double-sided originals are scanned. It is driven by the transistor (Q16). When the level of the GSOL-ON signal is set to "L", the flapper goes down and the original is transported to the reverse paper path.

The original exit solenoid is a solenoid that drives the flapper to switch the path, to which originals are to exit, to either the original reverse tray or the original exit tray. It is driven by the transistor (Q17). When the level of the SBSOL-ON signal is set to "L", and the original is transported to the original reverse tray.

[G] Reset circuit

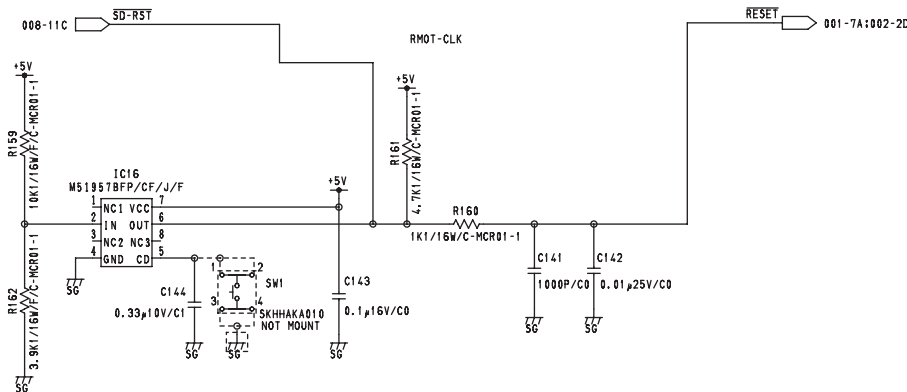

Fig. 15-11

This circuit generates a reset signal when the power is turned ON and when the power voltage is blocked or cut off/lowered temporarily. At the power-ON, the circuit shifts the level of the reset signal (RESET) from "L" to "H" to put the CPU in a operative state after the reset pulse duration (T_{pd}) determined by the capacitance of C144 has passed from when the power voltage has reached the supervisory voltage (V_s) divided by R162 and R159. When a power voltage drop (cutoff, temporary cutoff, temporary low voltage) occurs and the power voltage becomes lower than the set value for the supervisory voltage for the power, the circuit sets the level of the reset signal (RESET) to "L" to put the CPU in a halt state.

15.5 Disassembly and Replacement

15.5.1 RADF

- (1) Take off the top right cover, and rear cover (P.2-42 "[C] Top right cover", P.2-45 "[L] Rear cover").
- (2) Disconnect the connector.

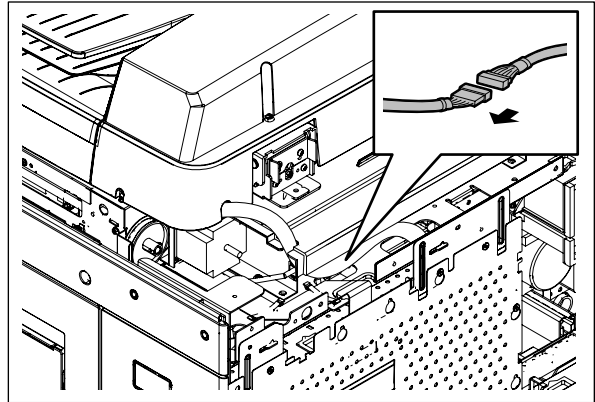

Fig. 15-12

- (3) Remove 2 screws.

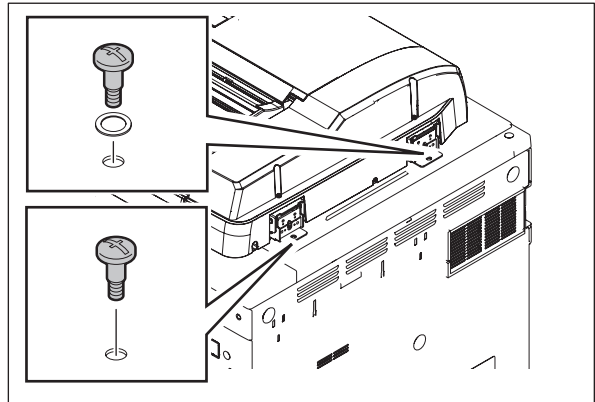

Fig. 15-13

- (4) Open the RADF and remove 2 screws.

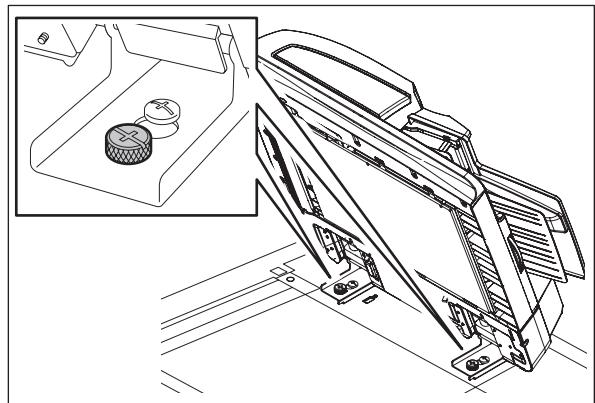

Fig. 15-14

- (5) Slide the RADF towards the rear side and take it off.

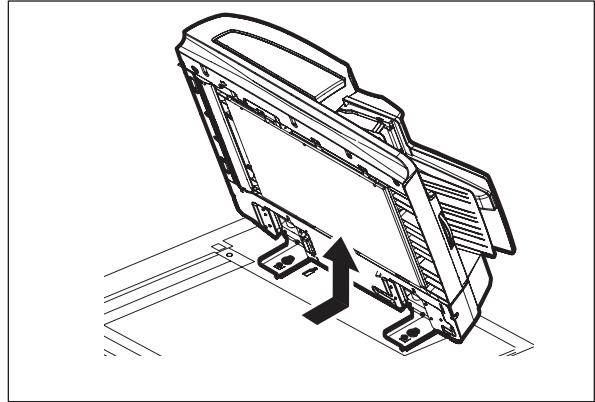

Fig. 15-15

15.5.2 RADF front cover

- (1) Open the original jam access cover and remove 2 screws.

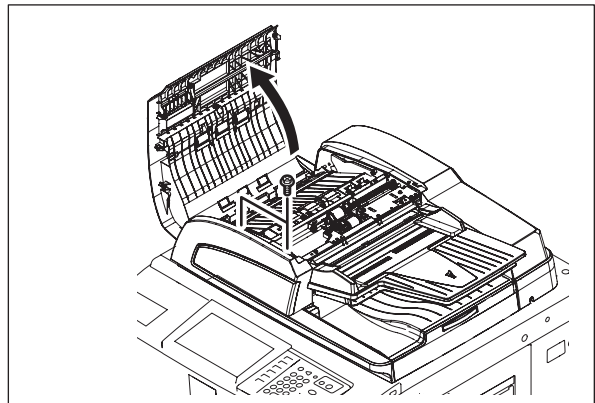

Fig. 15-16

- (2) Open the RADF and remove 4 screws.

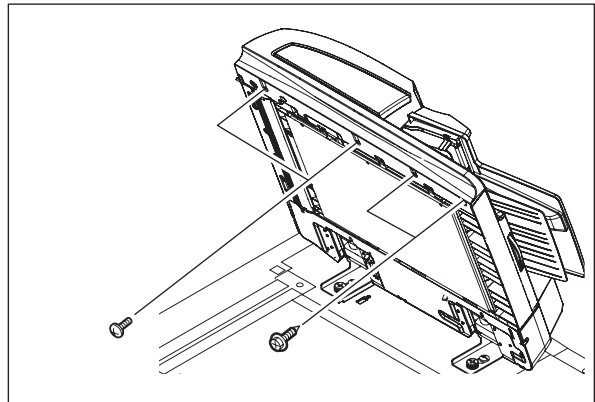

Fig. 15-17

- (3) Take off the RADF front cover.

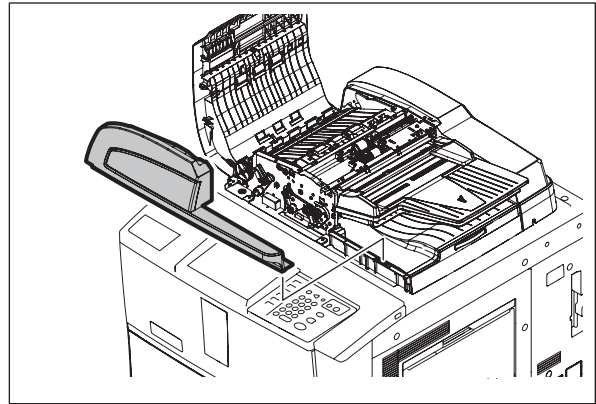

Fig. 15-18

15.5.3 RADF rear cover

- (1) Open the original jam access cover and remove 4 screws.

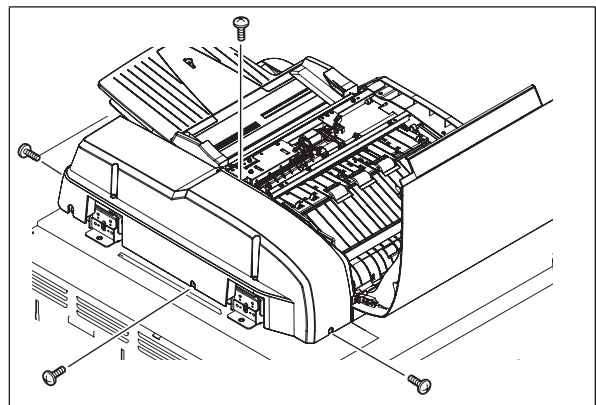

Fig. 15-19

- (2) Lift up the original tray and take off the RADF rear cover.

Note:

There is a Mylar attached to the hinge to prevent your fingers from being caught. Treat it carefully.

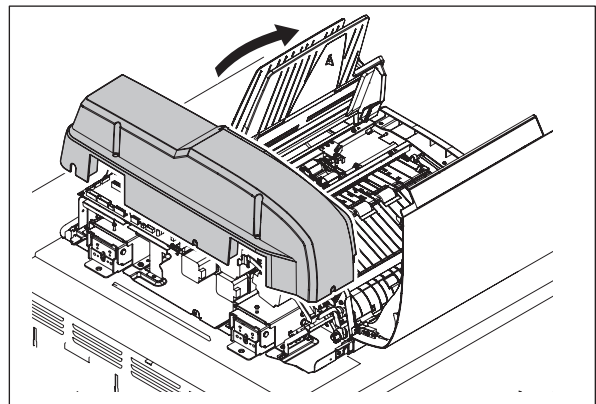

Fig. 15-20

15.5.4 Original jam access cover

- (1) Take off the RADF front cover.
📖 P.15-15 "15.5.2 RADF front cover"
- (2) Remove 1 clip and then the dial and pin.

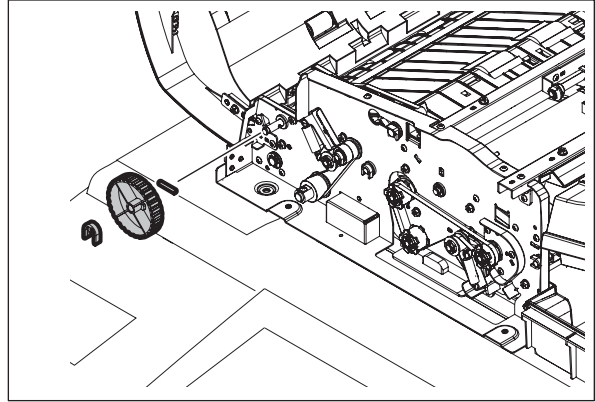

Fig. 15-21

- (3) Remove 2 screws and the hinge pin.

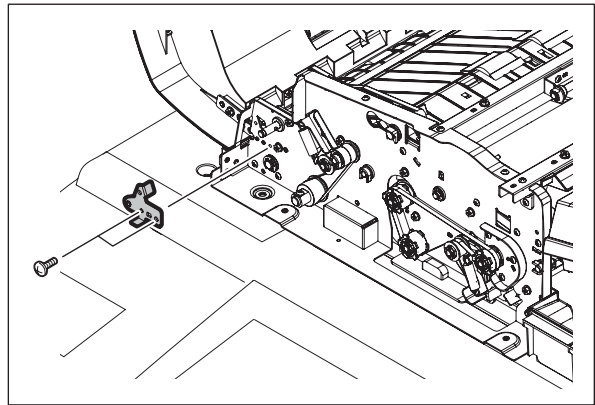

Fig. 15-22

- (4) Slide the original jam access cover to take it off.

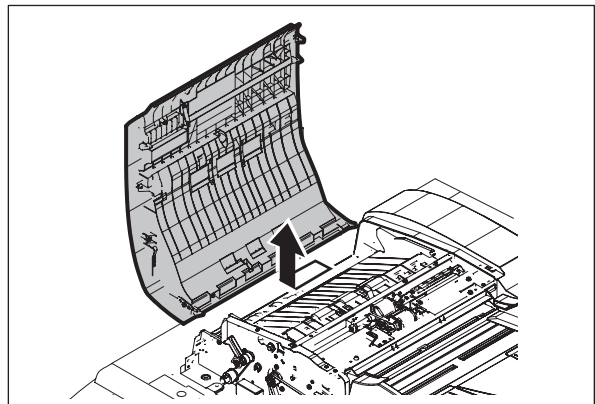

Fig. 15-23

15.5.5 RADF left cover

- (1) Remove the RADF front cover.
📖 P.15-15 "15.5.2 RADF front cover"
- (2) Remove the RADF rear cover.
📖 P.15-16 "15.5.3 RADF rear cover"
- (3) Remove 2 screws and take off the RADF left cover.

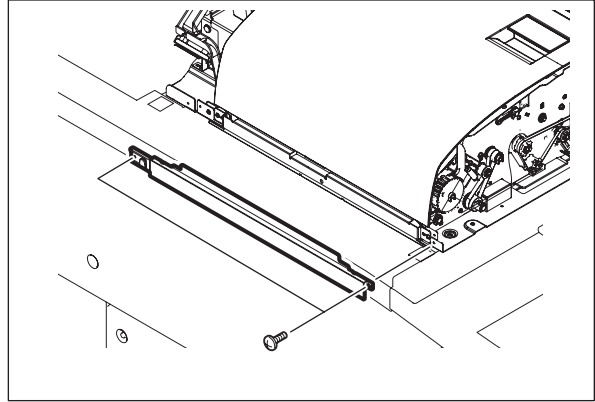

Fig. 15-24

15.5.6 Original tray

- (1) Take off the paper feeder unit.
📖 P.15-24 "15.5.12 Paper feeder unit"
- (2) Disconnect 1 connector from the RADF board.

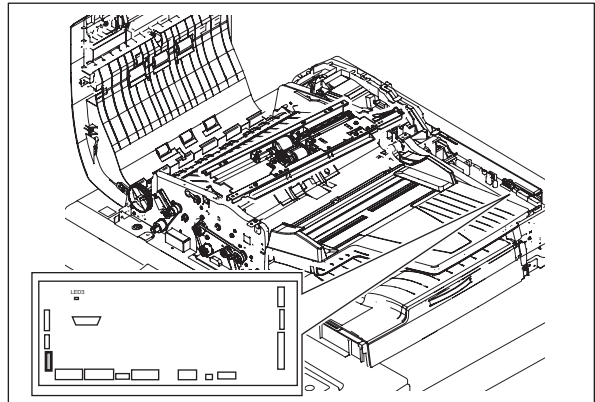

Fig. 15-25

- (3) Remove 1 screw and take off the bushing.

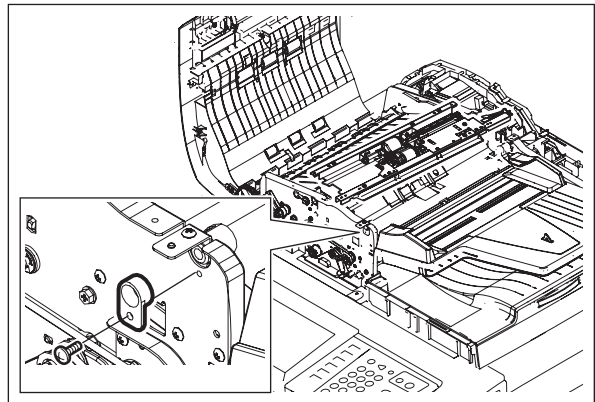

Fig. 15-26

- (4) Take off the original tray.

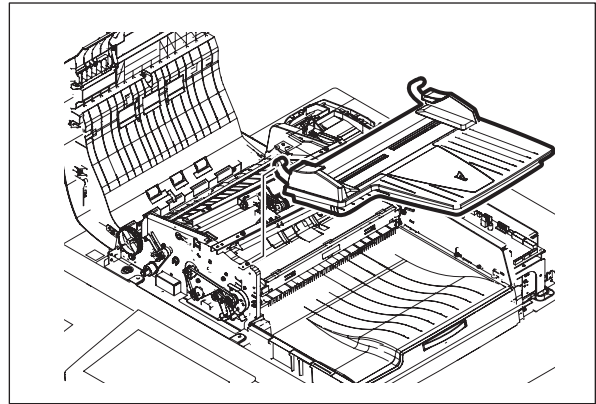

Fig. 15-27

15.5.7 Original reverse tray

- (1) Remove the original tray.
📖 P.15-18 "15.5.6 Original tray"
- (2) Remove 1 screw and take off the original reverse tray.

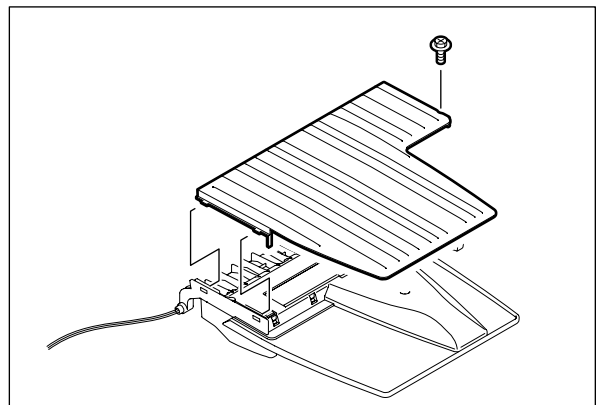

Fig. 15-28

15.5.8 Platen sheet unit

- (1) Open the RADF. Remove 5 screws and take off the platen sheet unit.

Notes:

1. Do not scratch or bend the platen sheet. Avoid adhesion of dust, dirt or foreign matter, especially things that may damage to the surface of the platen sheet.
2. When installing the platen sheet unit, be sure to perform the platen sheet adjustment.

📖 SERVICE HANDBOOK "3.12.9 Platen Sheet"

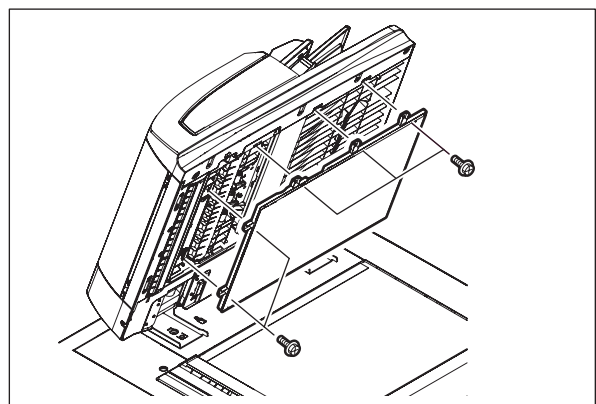

Fig. 15-29

15.5.9 RADF exit tray

- (1) Take off the RADF front cover.
📖 P.15-15 "15.5.2 RADF front cover"
- (2) Take off the RADF rear cover.
📖 P.15-16 "15.5.3 RADF rear cover"
- (3) Take off the platen sheet unit.
📖 P.15-19 "15.5.8 Platen sheet unit"
- (4) Remove 5 screws.

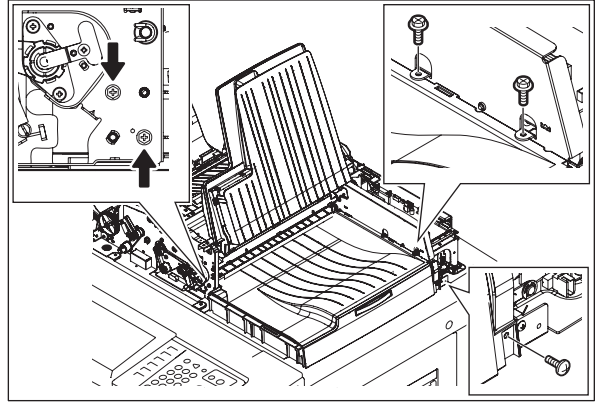

Fig. 15-30

- (5) Remove 1 screw.

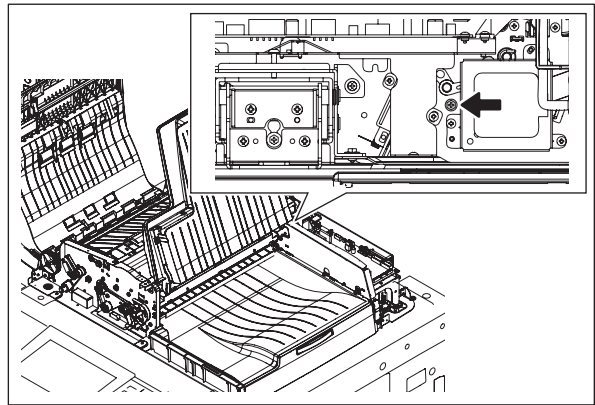

Fig. 15-31

- (6) Take off the RADF exit tray.

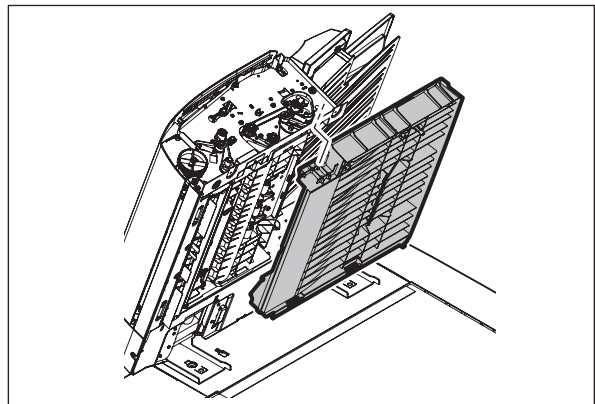

Fig. 15-32

15.5.10 Reading start guide unit

- (1) Take off the RADF rear cover.
☞ P.15-16 "15.5.3 RADF rear cover"
- (2) Take off the original jam access cover.
☞ P.15-17 "15.5.4 Original jam access cover"
- (3) Take off the RADF left cover.
☞ P.15-18 "15.5.5 RADF left cover"
- (4) Take off the RADF cooling fan.
☞ P.15-42 "15.5.30 RADF cooling fan (FR1)"
- (5) Remove 2 screws. Disconnect 2 connectors.

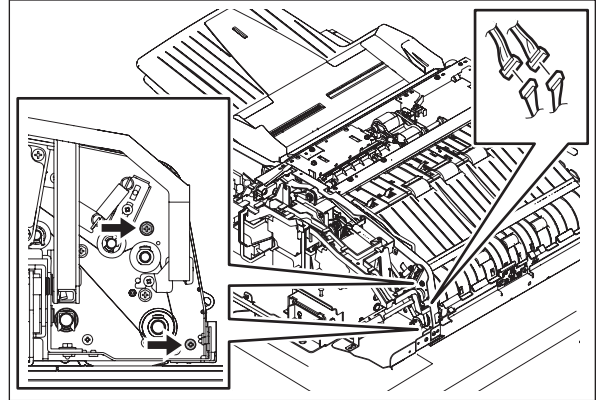

Fig. 15-33

- (6) Remove 2 screws.

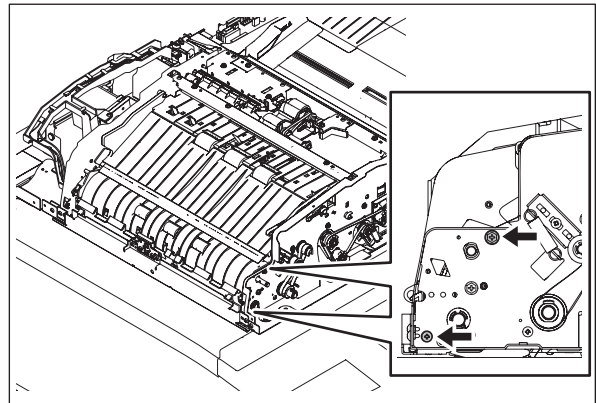

Fig. 15-34

- (7) Remove 2 screws and take off the reading start guide unit.

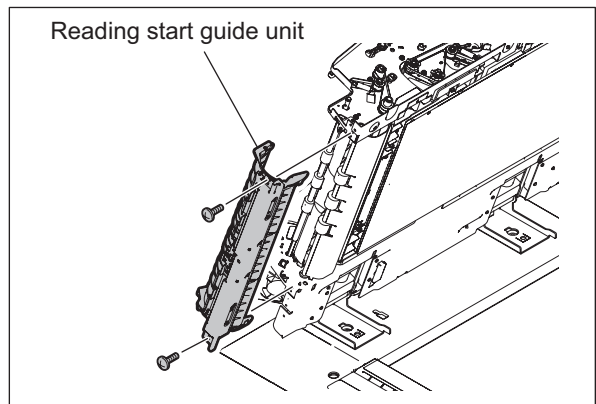

Fig. 15-35

15.5.11 Exit guide / Exit/reverse guide / Reading end guide

- (1) Take off the platen sheet unit.
📖 P.15-19 "15.5.8 Platen sheet unit"
- (2) Remove the RADF exit tray.
📖 P.15-20 "15.5.9 RADF exit tray"
- (3) Take off the original exit motor.
📖 P.15-41 "15.5.29 Original exit motor (MR4)"
- (4) Take off the original reverse motor.
📖 P.15-41 "15.5.28 Original reverse motor (MR3)"
- (5) Remove 1 clip, 1 pulley, 1 timing belt and 1 pin.

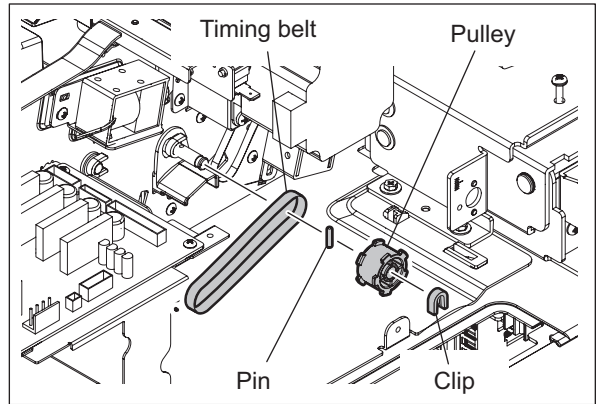

Fig. 15-36

- (6) Disconnect 1 connector. Remove 1 clip and take off the rear side guide bushing.

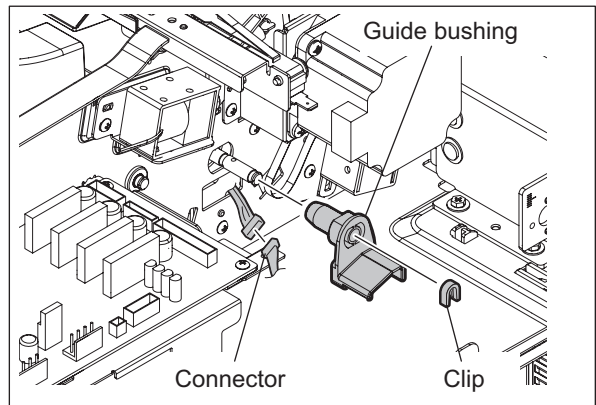

Fig. 15-37

- (7) Remove 1 screw and take off the leaf spring.

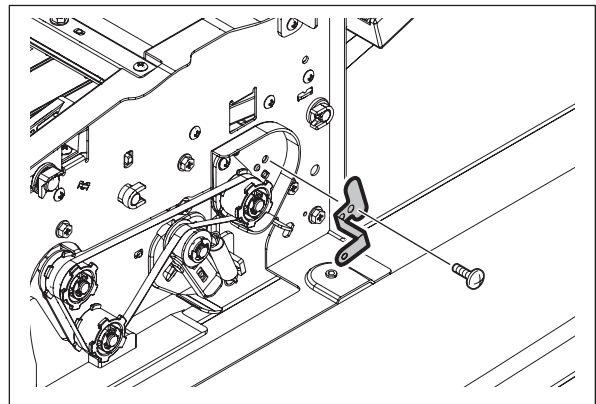

Fig. 15-38

(8) Remove 2 screws.

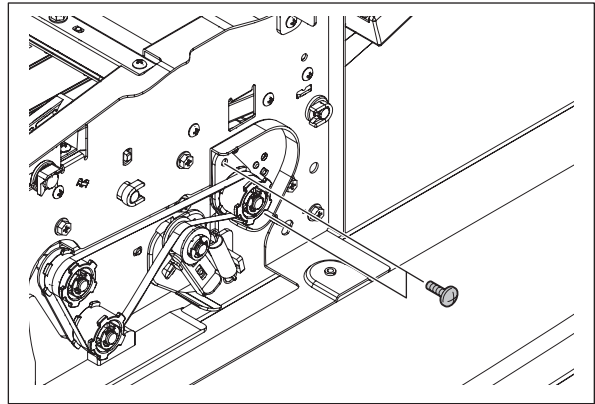

Fig. 15-39

(9) Take off the unit of exit guide and exit/reverse guide.

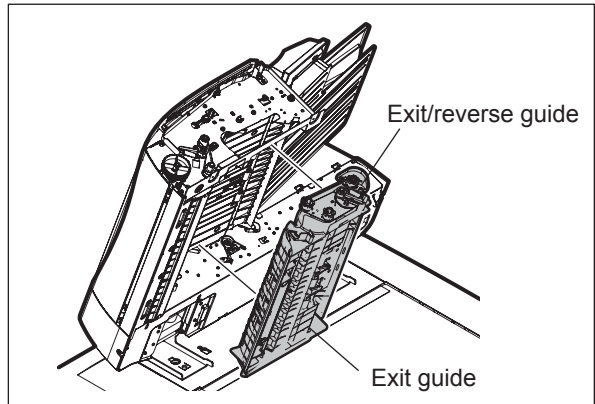

Fig. 15-40

(10) Disconnect 2 connectors, remove 2 screws and take off the reading end guide.

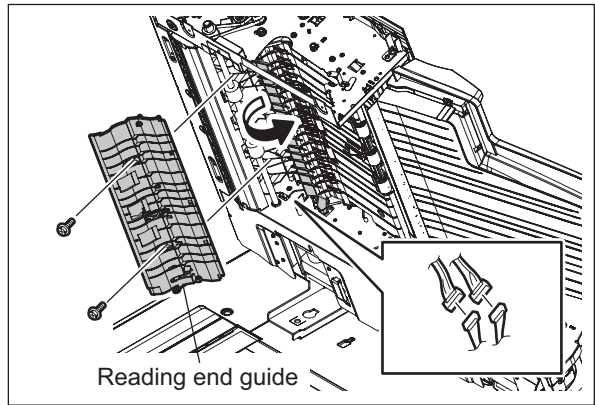

Fig. 15-41

(11) Remove 1 E-ring, 1 pulley, 1 pin, 1 timing belt, 1 guide bushing and the bracket.

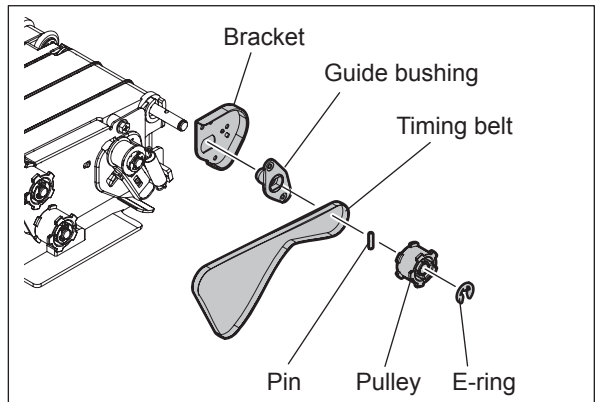

Fig. 15-42

- (12) Separate the reverse guide and the exit/reverse guide.

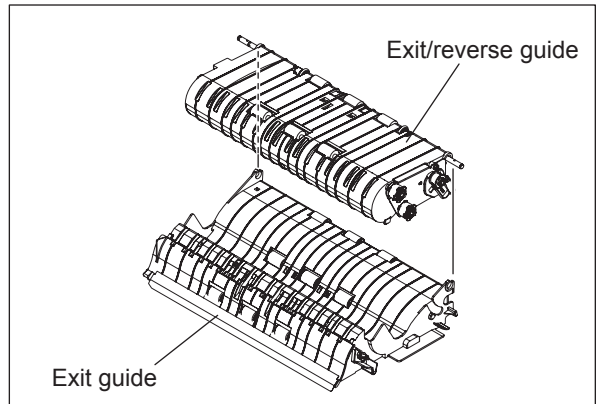

Fig. 15-43

15.5.12 Paper feeder unit

- (1) Open the original jam access cover. Then remove 2 screws and take off the arm unit on the front side.

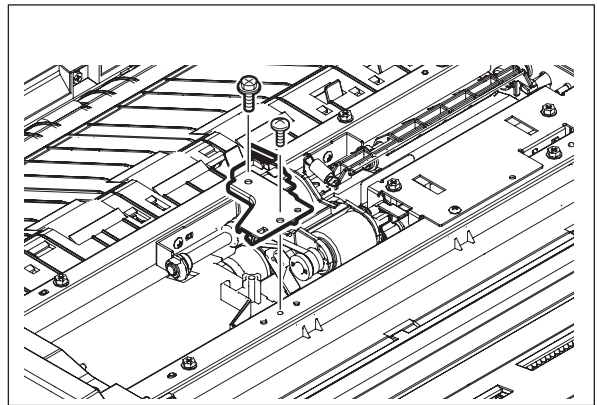

Fig. 15-44

- (2) Remove 1 clip and slide the bushing.

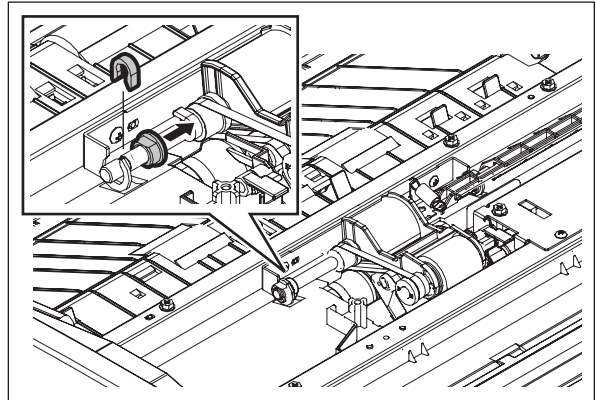

Fig. 15-45

- (3) Take off the paper feeder unit.

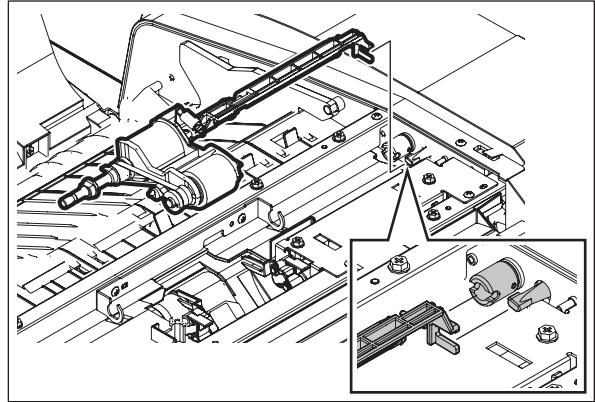



Fig. 15-46

15.5.13 Pickup roller

- (1) Take off the paper feeder unit.
 P.15-24 "15.5.12 Paper feeder unit"
- (2) Remove 1 clip. Then pull out the shaft and take off the pickup roller.

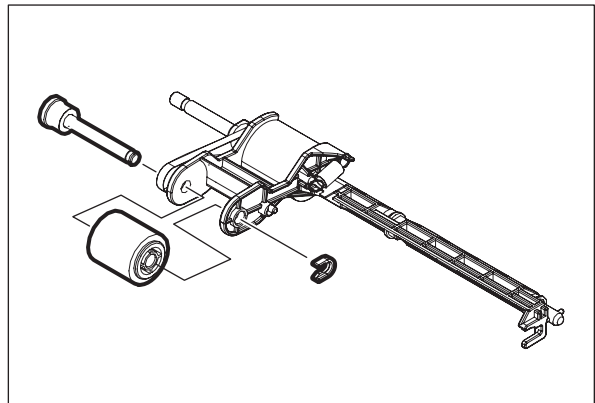

Fig. 15-47

Note:

Make sure you assemble the pickup roller with the one-way clutch in the correct direction.

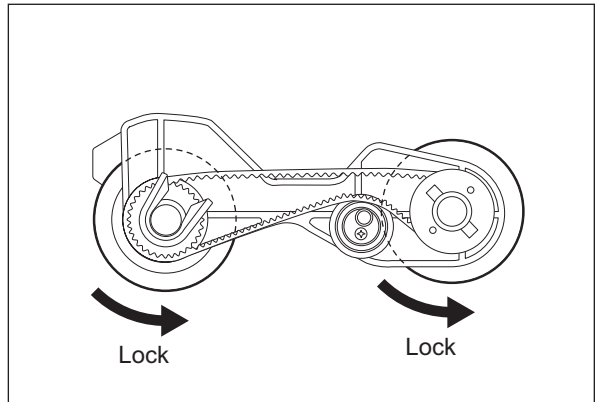



Fig. 15-48

15.5.14 Feed roller

- (1) Take off the paper feeder unit.
 P.15-24 "15.5.12 Paper feeder unit"
- (2) Remove 1 clip. Then slide the pulley and remove 1 pin.

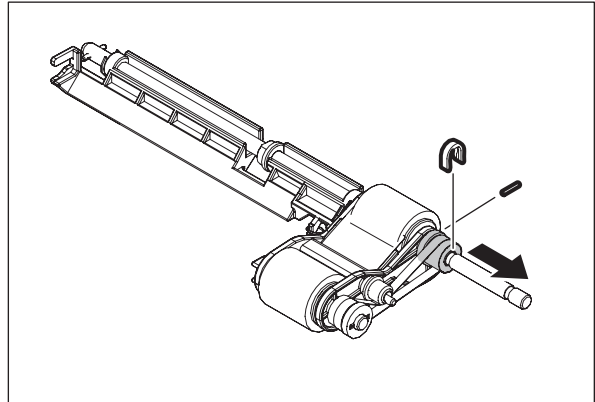

Fig. 15-49

- (3) Pull out the shaft and take off the feed roller.

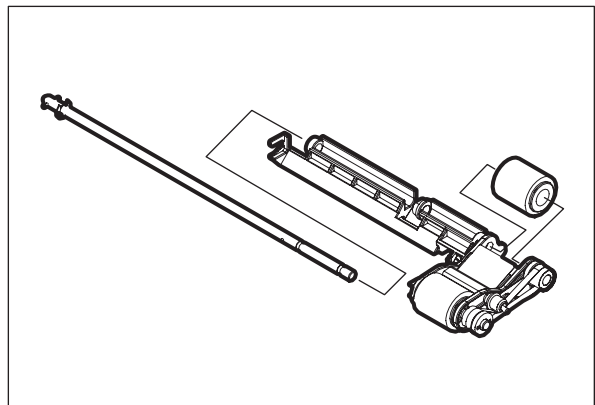

Fig. 15-50

Note:

Make sure you assemble the pickup roller with the one-way clutch in the correct direction.

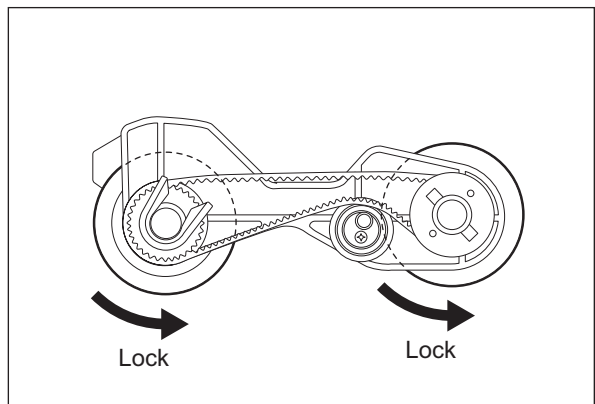



Fig. 15-51

15.5.15 Separation roller

- (1) Take off the RADF front cover.
 P.15-15 "15.5.2 RADF front cover"
- (2) Take off the RADF rear cover.
 P.15-16 "15.5.3 RADF rear cover"
- (3) Remove 4 screws and take off the feeder upper guide unit.

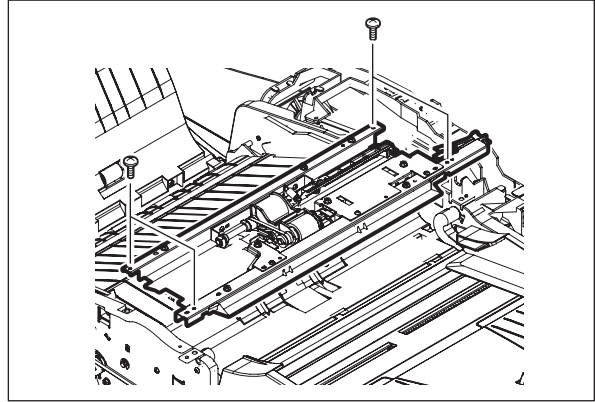

Fig. 15-52

- (4) Remove 1 screw and take off the separation roller holder. Then take off the separation roller unit.

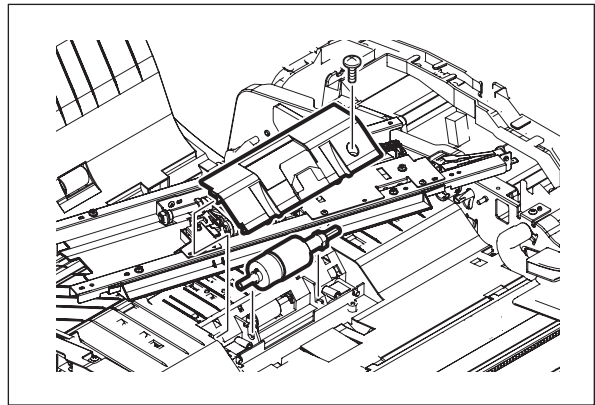

Fig. 15-53

- (5) Remove 1 E-ring and 1 bushing and then take off the separation roller.

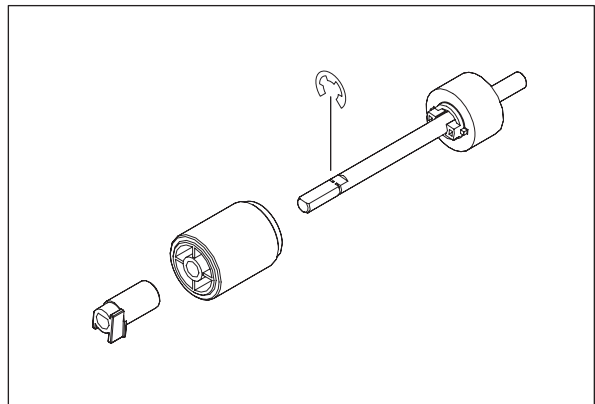

Fig. 15-54

15.5.16 Original registration roller

- (1) Take off the RADF front cover.
📖 P.15-15 "15.5.2 RADF front cover"
- (2) Take off the RADF rear cover.
📖 P.15-16 "15.5.3 RADF rear cover"
- (3) Loosen 1 screw.

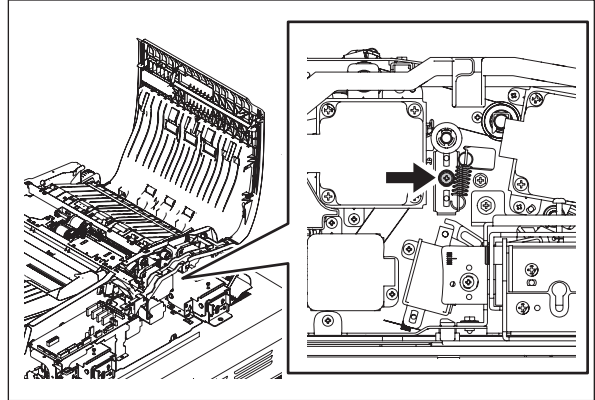

Fig. 15-55

- (4) Remove 1 clip, 1 pulley and 1 bushing.

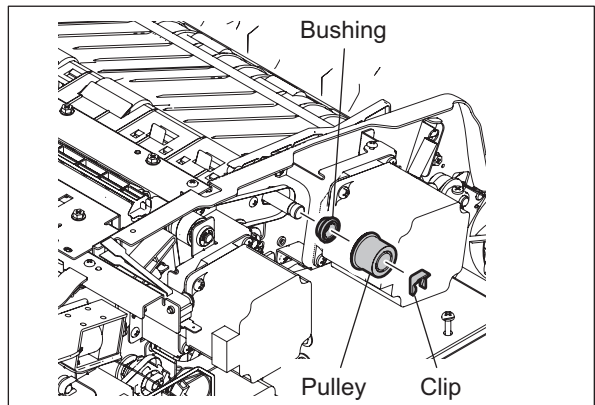

Fig. 15-56

- (5) Remove 1 clip and 1 bushing.

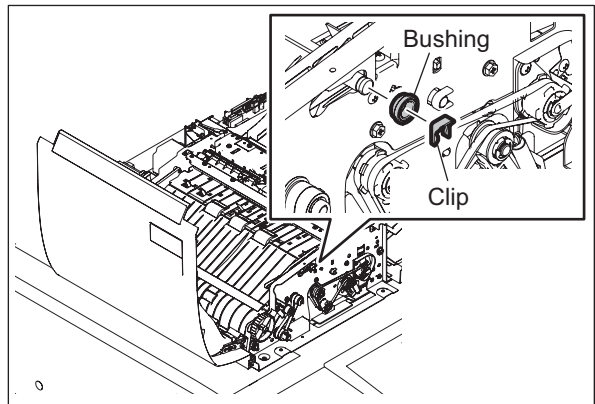

Fig. 15-57

- (6) Lift the guide. Take off the original registration roller.

Note:

When installing the original registration roller, refix the loosened screw and tighten the belt tension.

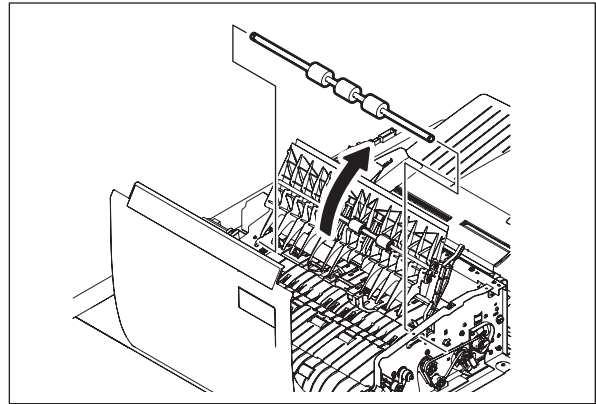

Fig. 15-58

15.5.17 Intermediate transport roller

- (1) Take off the reading start guide unit.
P.15-21 "15.5.10 Reading start guide unit"
(2) Loosen 1 screw.

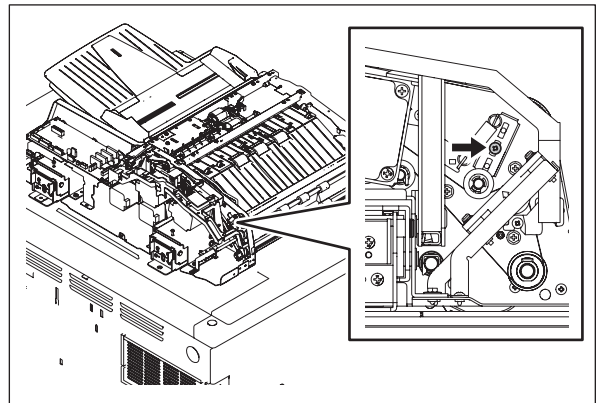

Fig. 15-59

- (3) Remove 1 screw.

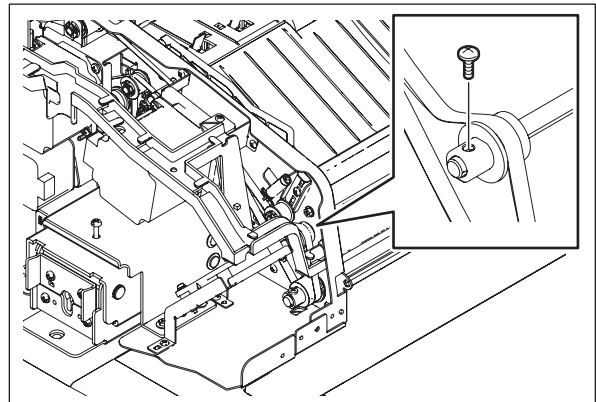

Fig. 15-60

- (4) Remove 1 E-ring and 1 bushing (front side). Slide the intermediate transport roller, remove 1 pulley and 1 bushing, and take off the intermediate transport roller.

Note:

When installing the intermediate transport roller, refix the loosened screw and tighten the belt tension.

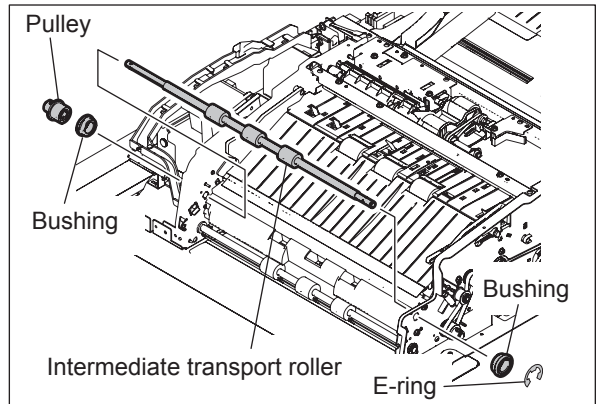



Fig. 15-61

15.5.18 Reading start roller

- (1) Take off the reading start guide unit.
 P.15-21 "15.5.10 Reading start guide unit"
- (2) Loosen 1 screw.

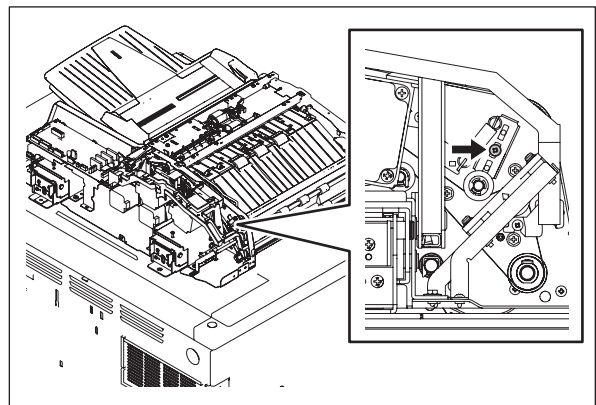

Fig. 15-62

- (3) Remove 1 screw. Remove 1 timing belt, 1 pulley and 1 bearing.

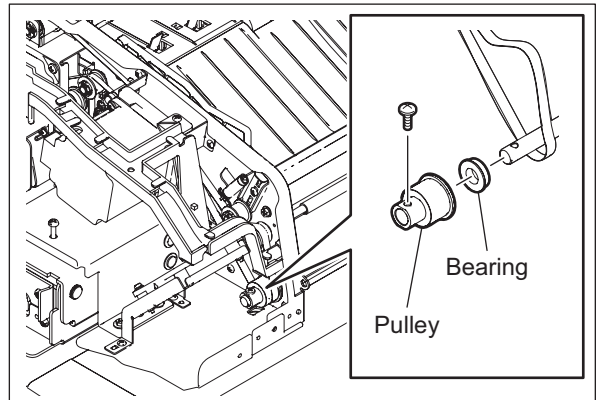

Fig. 15-63

- (4) Remove 1 E-ring and 1 bushing.

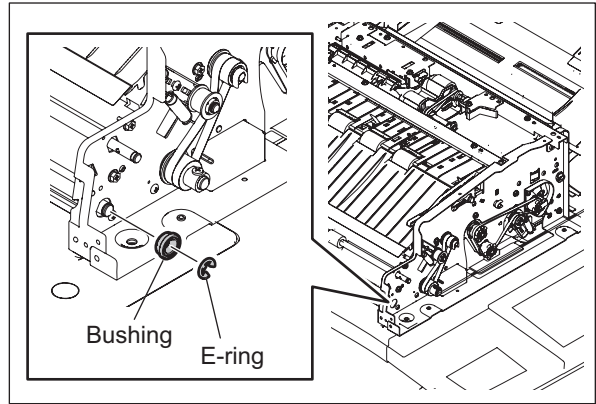

Fig. 15-64

- (5) Remove 4 screws and take off the platen guide.

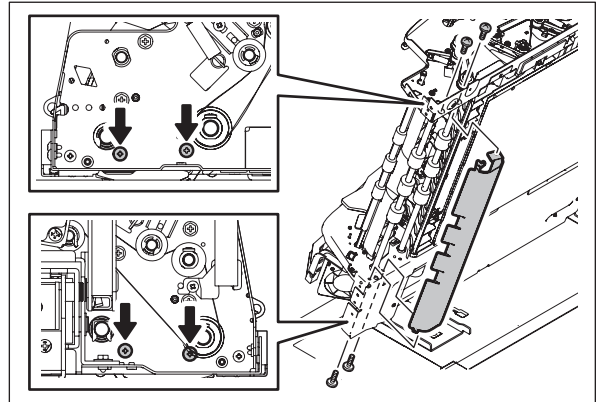

Fig. 15-65

- (6) Take off the reading start roller.

Note:

When installing the reading start roller, refix the loosened screw and tighten the belt tension.

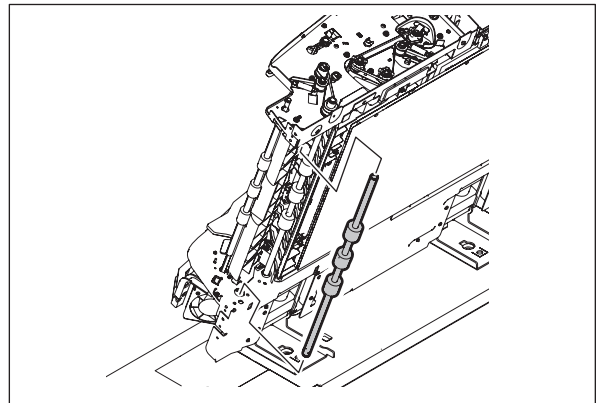

Fig. 15-66

15.5.19 Reading end roller

- (1) Take off the RADF front cover.
📖 P.15-15 "15.5.2 RADF front cover"
- (2) Take off the RADF rear cover.
📖 P.15-16 "15.5.3 RADF rear cover"
- (3) Remove 1 clip and 1 bushing.

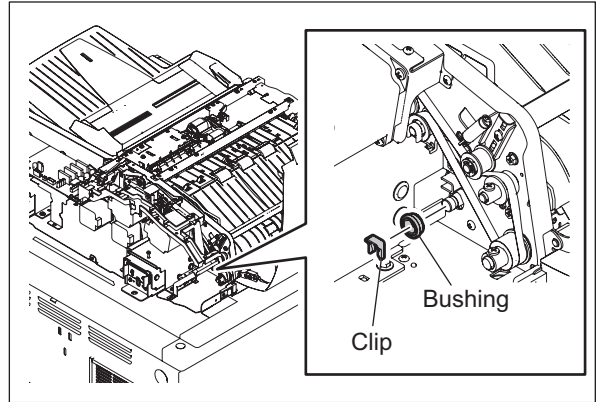

Fig. 15-67

- (4) Loosen 1 screw.

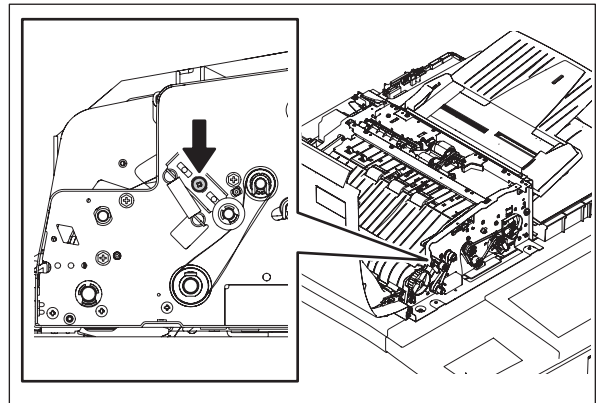

Fig. 15-68

- (5) Remove 1 screw, 1 pulley, 1 bearing and 1 timing belt.

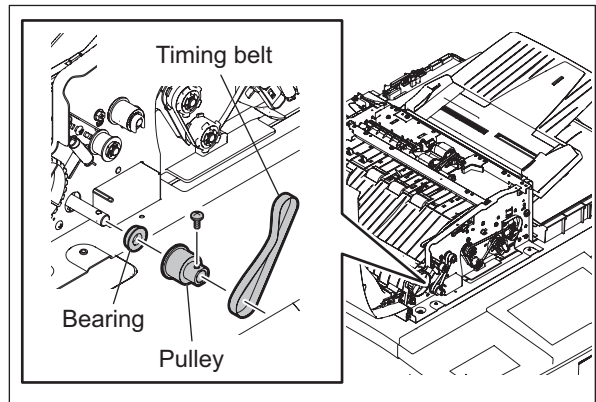



Fig. 15-69

- (6) Take off the reading end guide.
 P.15-22 "15.5.11 Exit guide / Exit/reverse guide / Reading end guide"
- (7) Take off the reading end roller.

Note:

When installing the reading end roller, refix the loosened screw and tighten the belt tension.

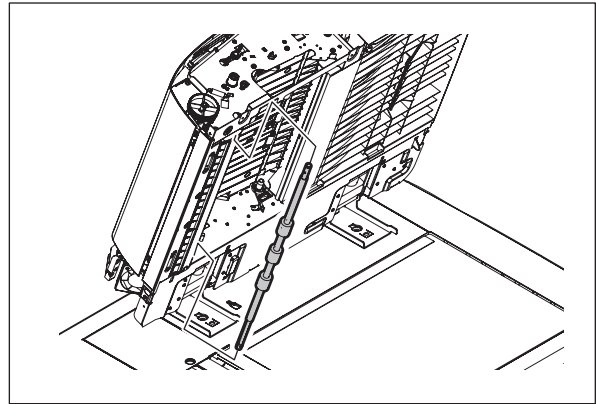



Fig. 15-70

15.5.20 Exit roller

- (1) Take off the reading end guide.
 P.15-22 "15.5.11 Exit guide / Exit/reverse guide / Reading end guide"
- (2) Remove 2 screws and take off the guide.

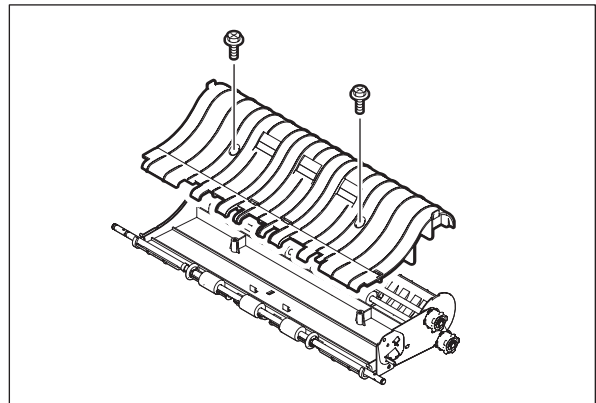

Fig. 15-71

- (3) Take off the exit roller.

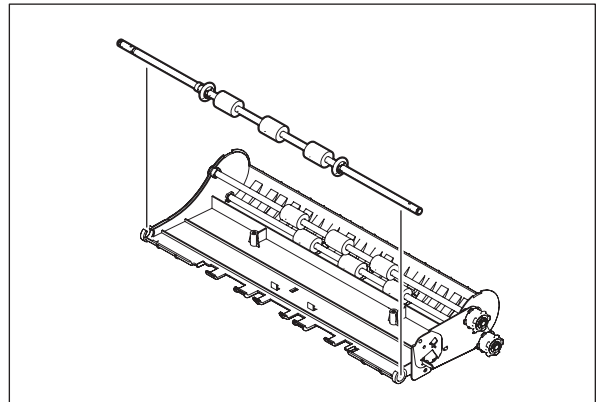

Fig. 15-72

15.5.21 Exit/reverse roller

- (1) Take off the exit/reverse guide.
P.15-22 "15.5.11 Exit guide / Exit/reverse guide / Reading end guide"
- (2) Remove 2 screws and take off the guide.

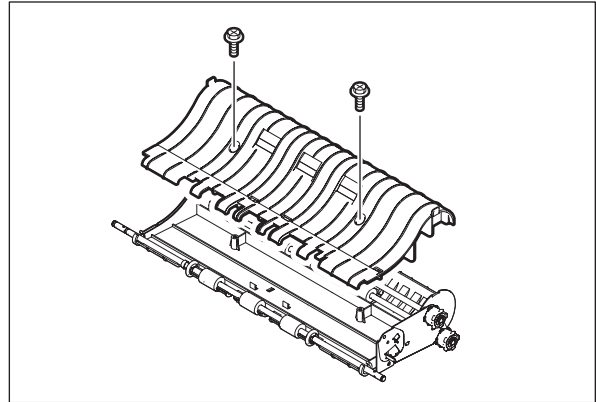

Fig. 15-73

- (3) Remove 1 E-ring, 1 pulley, 1 pin and 1 bushing.

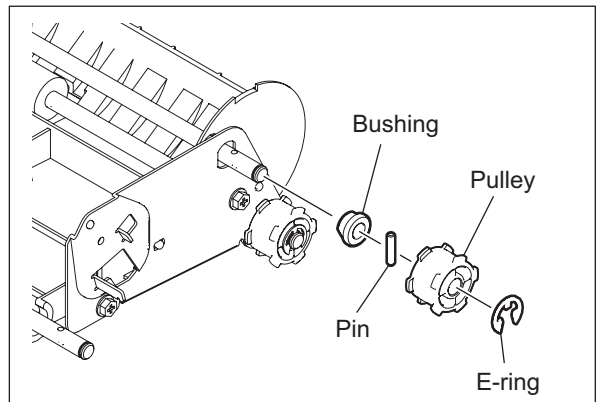

Fig. 15-74

- (4) Take off the exit/reverse roller, remove 1 E-ring and 1 bushing.

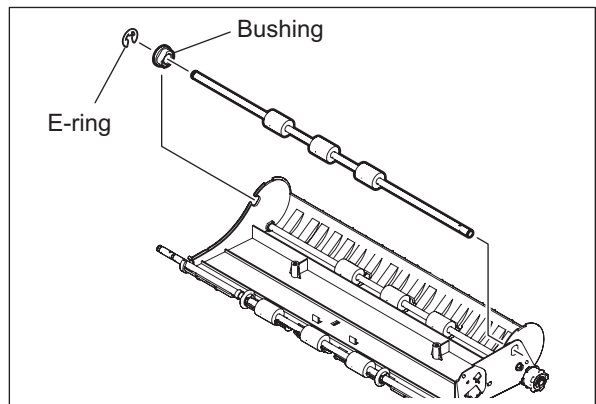

Fig. 15-75

15.5.22 Exit intermediate roller

- (1) Take off the exit/reverse guide.
📖 P.15-22 "15.5.11 Exit guide / Exit/reverse guide / Reading end guide"
- (2) Remove 2 screws and take off the guide.

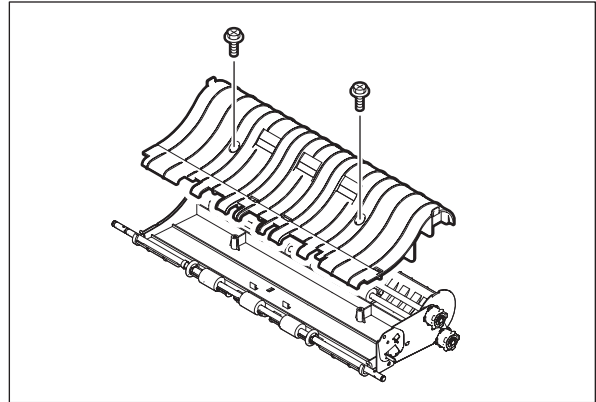

Fig. 15-76

- (3) Remove 1 E-ring, 1 pulley, 1 pin and 1 bushing.

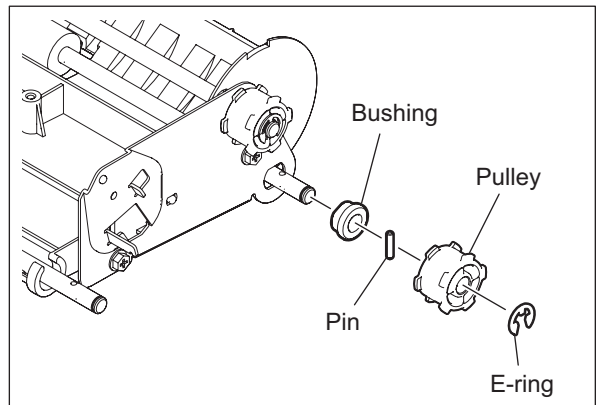

Fig. 15-77

- (4) Remove 1 E-ring and 1 bushing and take off the exit intermediate roller.

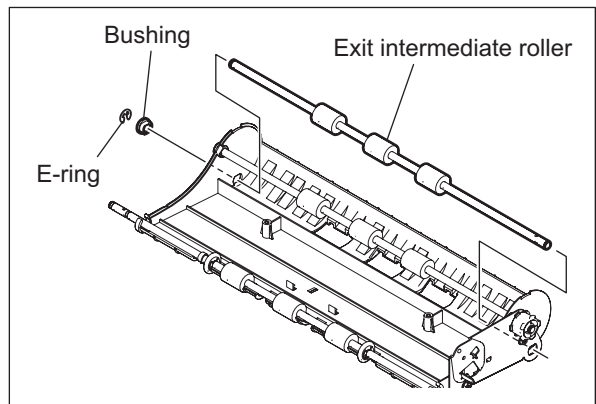

Fig. 15-78

15.5.23 Reverse roller

- (1) Take off the assembly of the exit guide and the exit/reverse guide.
📖 P.15-22 "15.5.11 Exit guide / Exit/reverse guide / Reading end guide"
- (2) Remove 2 screws and take off the 2 leaf springs.

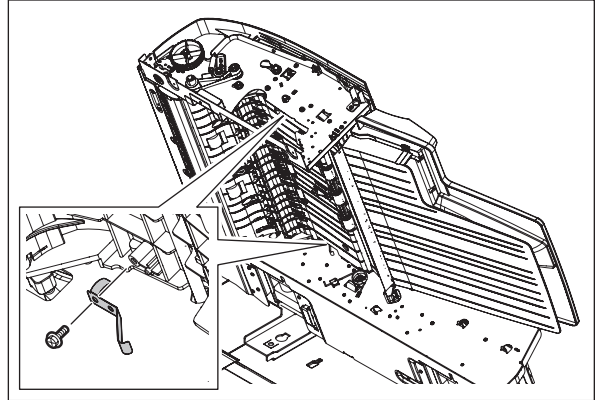

Fig. 15-79

- (3) Remove 3 screws and take off the upper reverse guide.

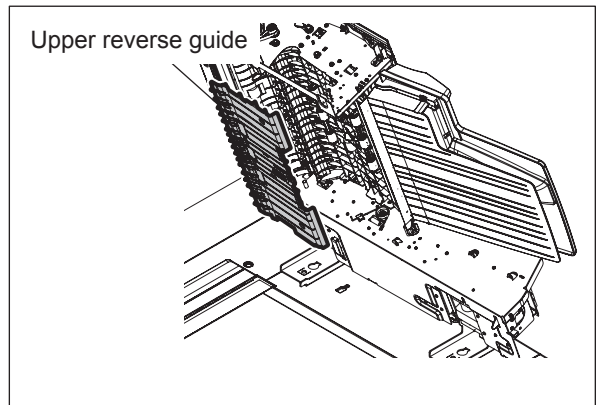

Fig. 15-80

- (4) Take off the original feed motor bracket with the motor.
📖 P.15-38 "15.5.25 Original feed motor bracket"
- (5) Remove 1 clip, 1 pulley, 1 pin and 1 bushing.

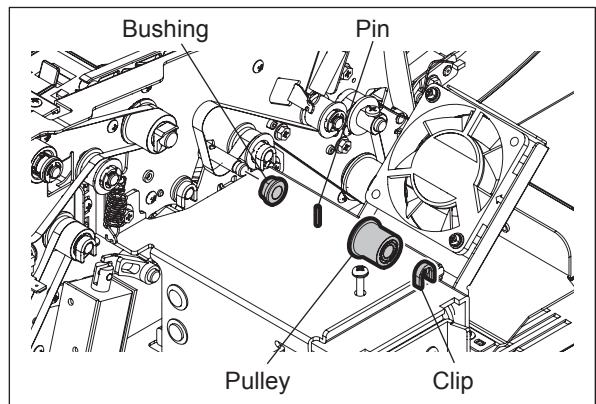

Fig. 15-81

(6) Remove 1clip and 1 bushing.

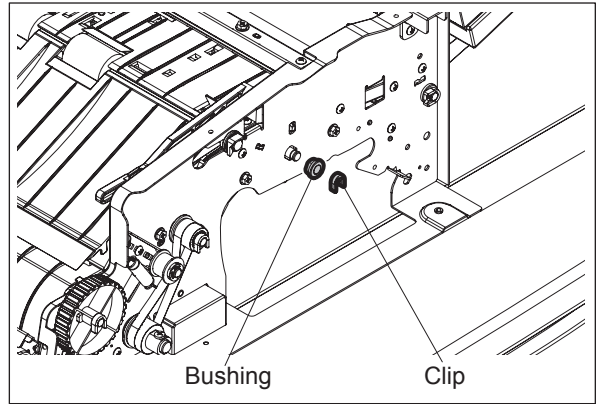

Fig. 15-82

(7) Remove the reverse roller.

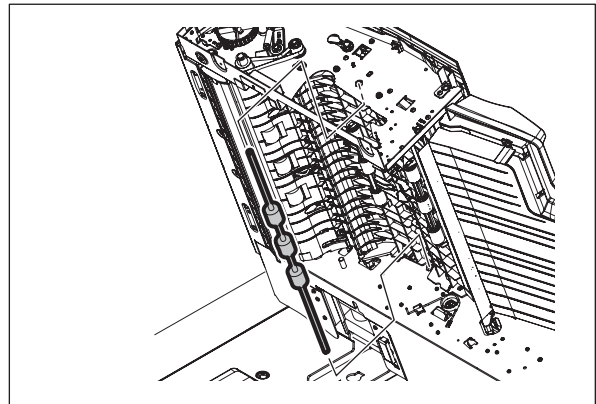

Fig. 15-83

15.5.24 Original feed motor (MR1)

- (1) Take off the RADF rear cover.
P.15-16 "15.5.3 RADF rear cover"
- (2) Loosen 1 screw.

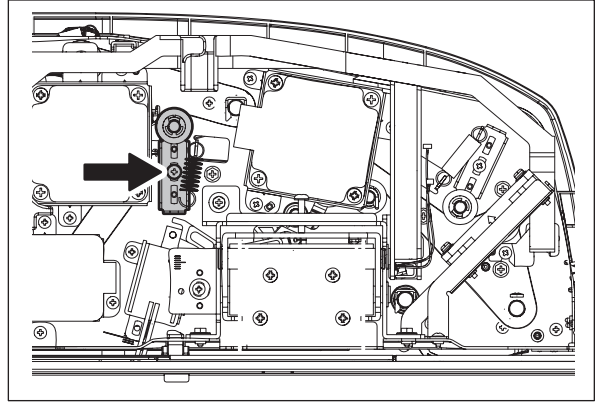

Fig. 15-84

- (3) Disconnect 1 connector, remove 2 screws and take off the original feed motor.

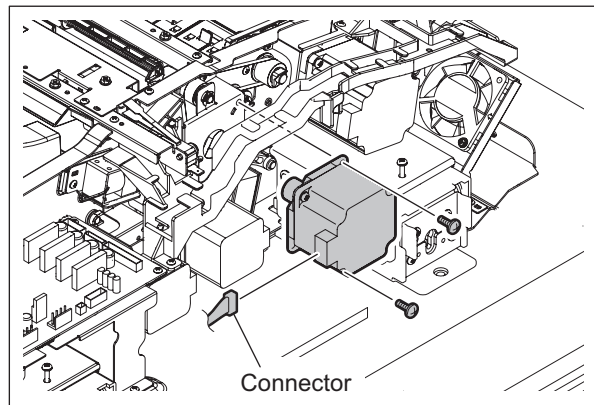

Fig. 15-85

15.5.25 Original feed motor bracket

- (1) Take off the RADF rear cover.
P.15-16 "15.5.3 RADF rear cover"
- (2) Loosen 1 screw.

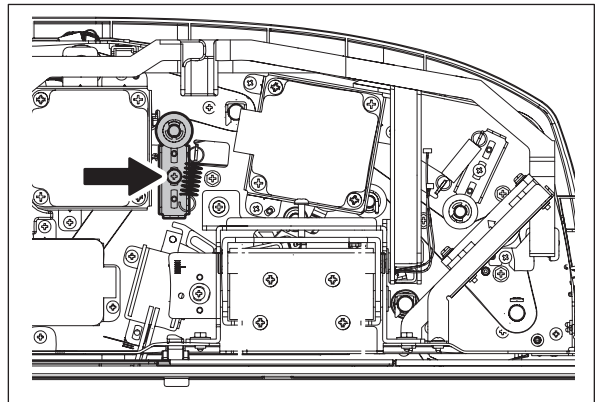

Fig. 15-86

- (3) Remove 1 E-ring and 1 bushing.

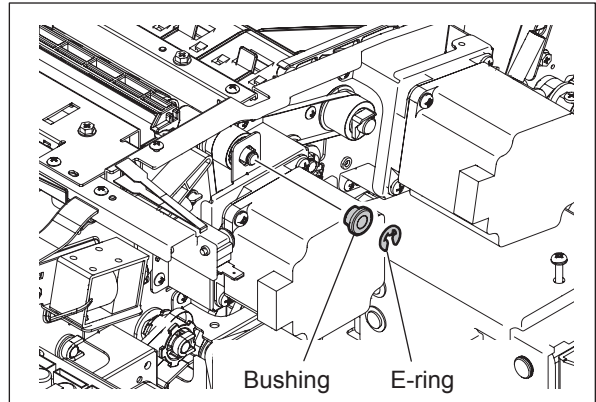

Fig. 15-87

- (4) Disconnect 1 connector.
- (5) Remove 3 screws and take off the original feed motor bracket with the motor.

Note:

When installing the original feed motor bracket, refix the loosened screw and tighten the belt tension.

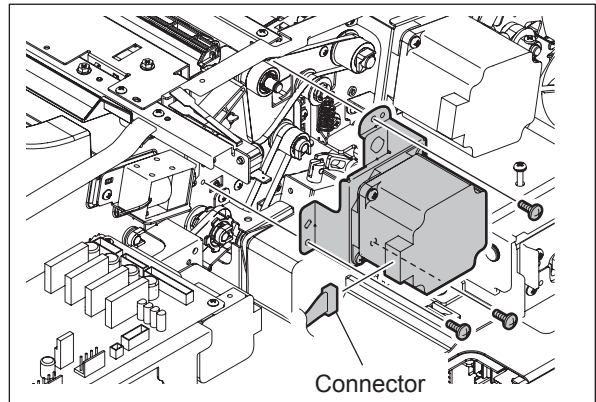

Fig. 15-88

15.5.26 Read motor (MR2)

- (1) Take off the RADF rear cover.
P.15-16 "15.5.3 RADF rear cover"
- (2) Loosen 1 screw.

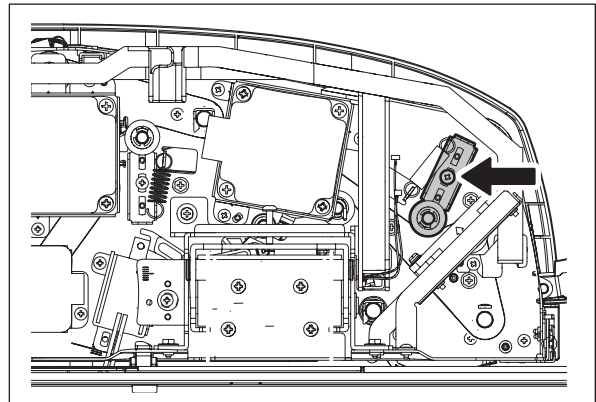

Fig. 15-89

- (3) Disconnect 1 connector.
- (4) Remove 3 screws and take off the read motor.

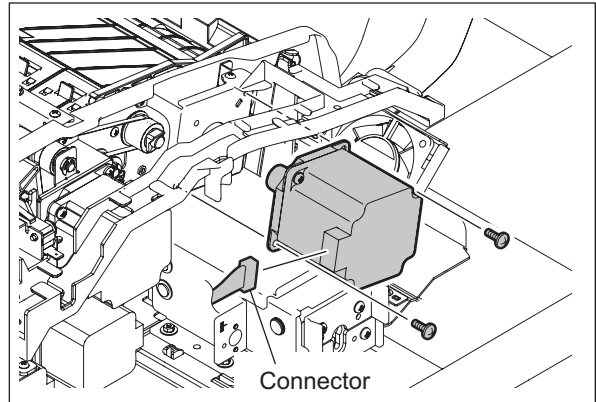

Fig. 15-90

15.5.27 Read motor bracket

- (1) Take off the RADF rear cover.
 P.15-16 "15.5.3 RADF rear cover"
- (2) Loosen 1 screw.

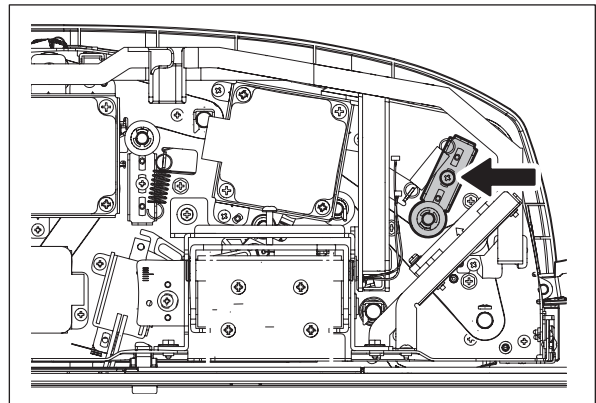

Fig. 15-91

- (3) Disconnect 1 connector.
- (4) Remove 3 screws and take off the read motor bracket with the motor.

Note:

When installing the read motor bracket, refix the loosened screw and tighten the belt tension.

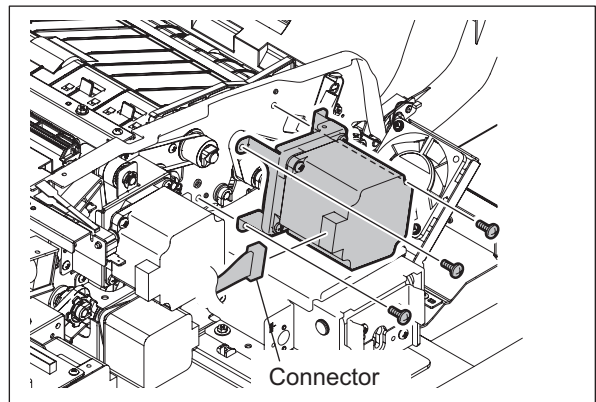

Fig. 15-92

15.5.28 Original reverse motor (MR3)

- (1) Take off the RADF rear cover.
P.15-16 "15.5.3 RADF rear cover"
- (2) Disconnect 1 connector.
- (3) Remove 3 screws and take off the original reverse motor with the bracket.

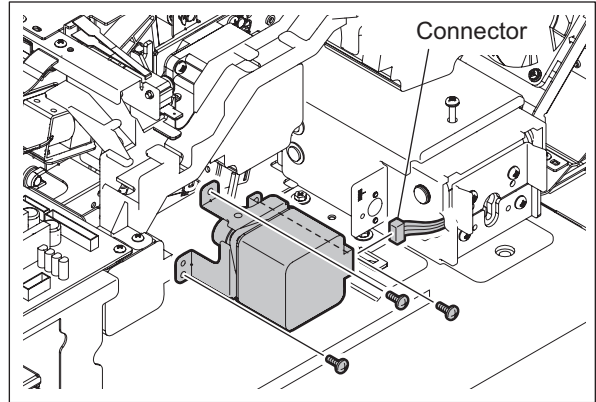

Fig. 15-93

- (4) Remove 2 screws and take off the bracket from the original reverse motor.

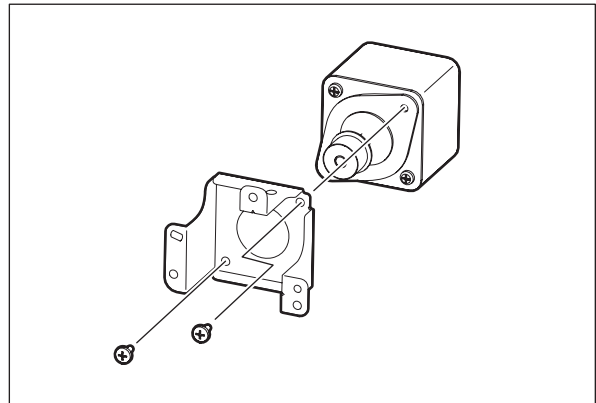

Fig. 15-94

15.5.29 Original exit motor (MR4)

- (1) Take off the RADF rear cover.
P.15-16 "15.5.3 RADF rear cover"
- (2) Disconnect 1 connector.
- (3) Remove 3 screws and take off the original exit motor with the bracket.

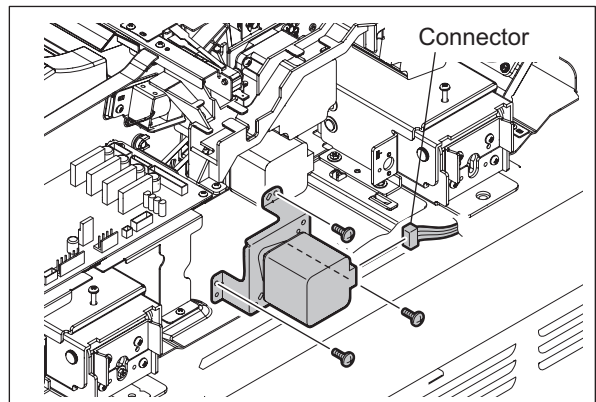

Fig. 15-95

- (4) Remove 2 screws and take off the bracket from the original exit motor.

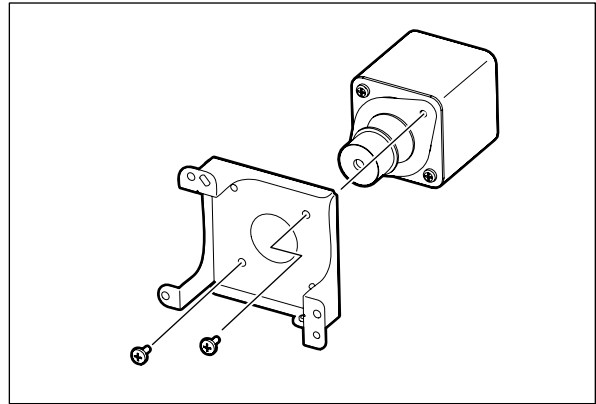

Fig. 15-96

15.5.30 RADF cooling fan (FR1)

- (1) Take off the RADF rear cover.
P.15-16 "15.5.3 RADF rear cover"
- (2) Disconnect 1 connector.
- (3) Remove 2 screws and take off the RADF cooling fan with the bracket.

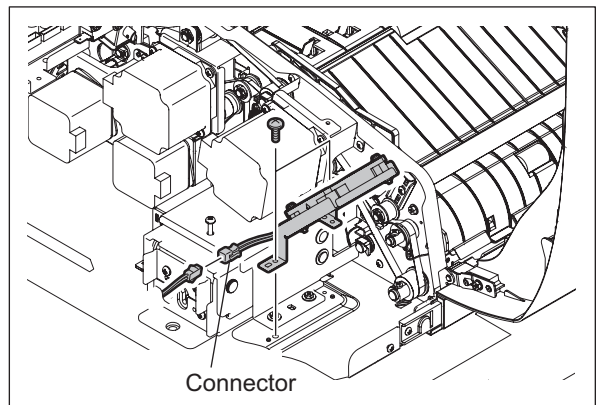

Fig. 15-97

- (4) Remove 2 screws and take off the bracket from the RADF cooling fan.

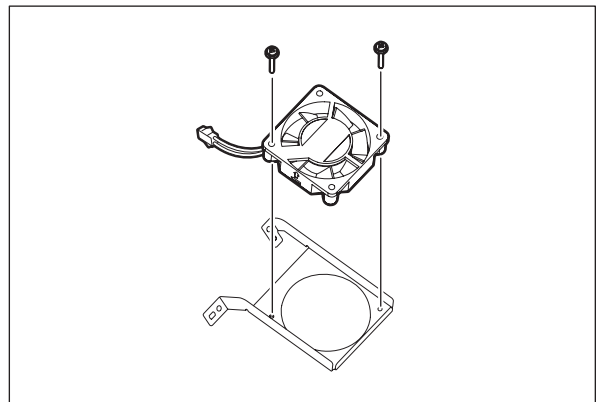

Fig. 15-98

15.5.31 Original pickup solenoid (SOLR1)

- (1) Take off the RADF rear cover.
☞ P.15-16 "15.5.3 RADF rear cover"
- (2) Disconnect 1 connector.
- (3) Remove 2 screws and take off the original pickup solenoid.

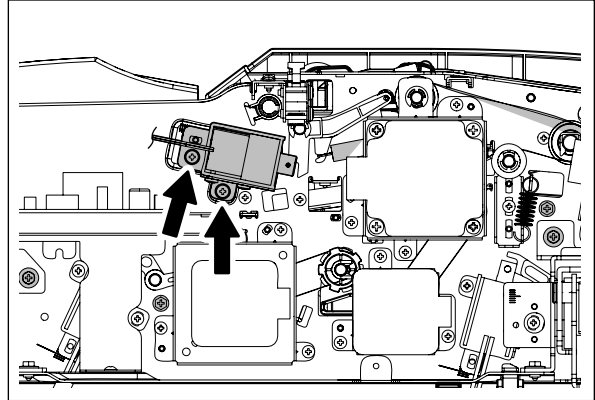

Fig. 15-99

- (4) Remove 2 screws and take off the bracket from the original pickup solenoid.

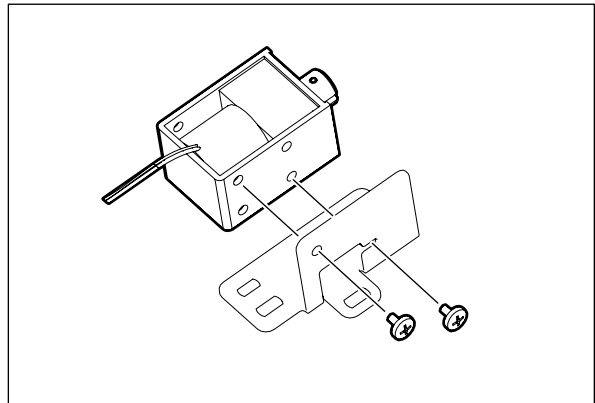

Fig. 15-100

Note:

Before taking off the solenoid, read the scale.
When reinstalling, align it with the corresponding position on the scale.

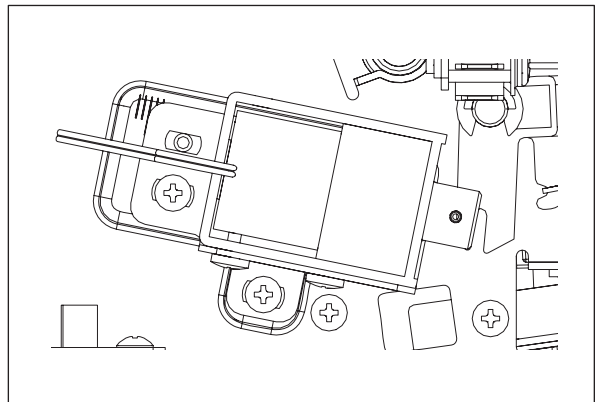

Fig. 15-101

15.5.32 Original reverse solenoid (SOLR2)

- (1) Take off the RADF rear cover.
📖 P.15-16 "15.5.3 RADF rear cover"
- (2) Disconnect 1 connector.
- (3) Remove 2 screws and take off the original reverse solenoid with the bracket.

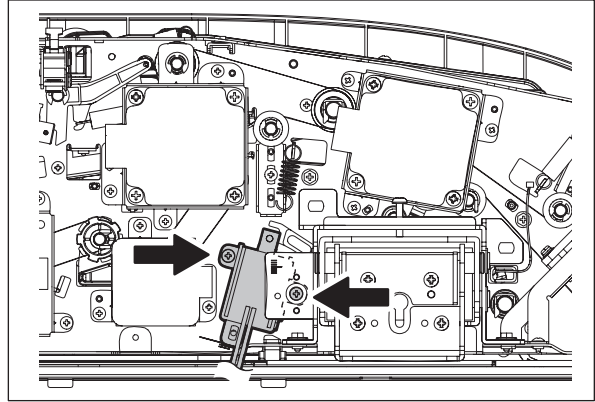

Fig. 15-102

- (4) Remove 2 screws and take off the bracket from the original reverse solenoid.

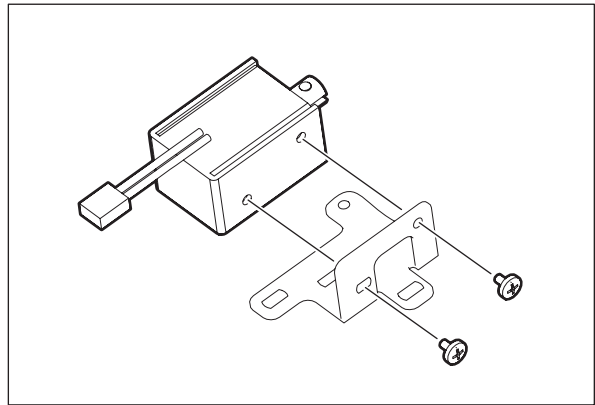

Fig. 15-103

Note:

Before taking off the solenoid, read the scale.
When reinstalling, align it with the corresponding position on the scale.

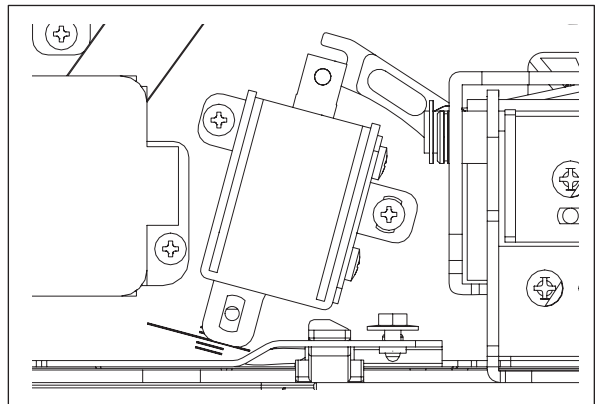

Fig. 15-104

15.5.33 Original exit solenoid (SOLR3)

- (1) Take off the RADF board bracket.
📖 P.15-16 "15.5.3 RADF rear cover"
- (2) Disconnect 1 connector.
- (3) Remove 2 screws and take off the original exit solenoid with the bracket.

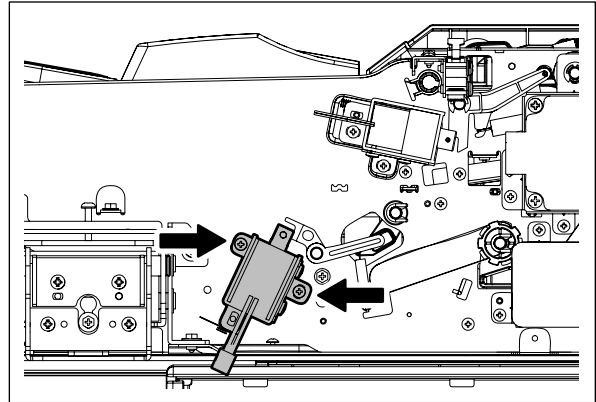

Fig. 15-105

- (4) Remove 2 screws and take off the bracket from the original exit solenoid.

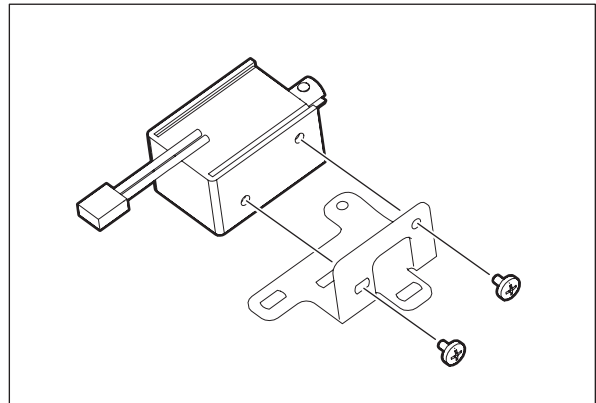

Fig. 15-106

Note:

Before taking off the solenoid, read the scale.
When reinstalling, align it with the corresponding position on the scale.

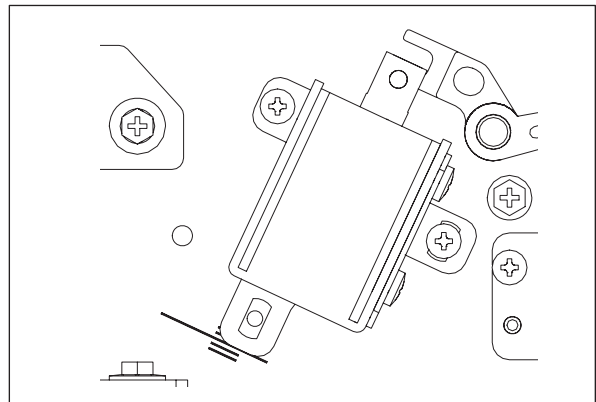

Fig. 15-107

15.5.34 Original jam access cover opening/closing switch (SWR1)

- (1) Take off the RADF board bracket.
📖 P.15-16 "15.5.3 RADF rear cover"
- (2) Take off the harness guide.
📖 P.15-38 "15.5.25 Original feed motor bracket"
- (3) Disconnect 3 connectors.

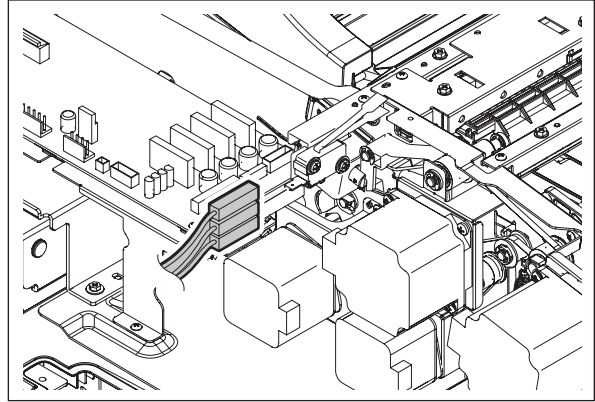

Fig. 15-108

- (4) Remove 1 screw and take off the original jam access cover opening/closing switch.

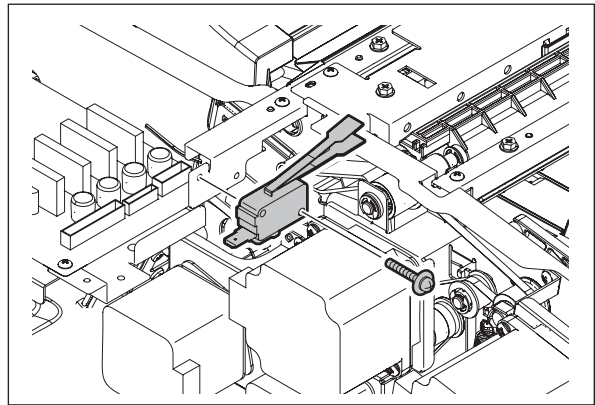

Fig. 15-109

15.5.35 RADF opening/closing switch (SWR2)

- (1) Take off the RADF board bracket.
📖 P.15-58 "15.5.54 RADF board bracket"
- (2) Disconnect 3 connectors.

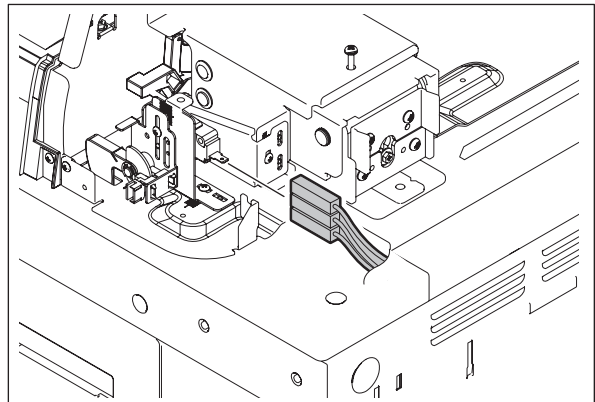

Fig. 15-110

- (3) Remove 1 screw and take off the switch bracket.

Note:

Before taking off the switch, read the scale.
When reinstalling, align it with the corresponding position on the scale.

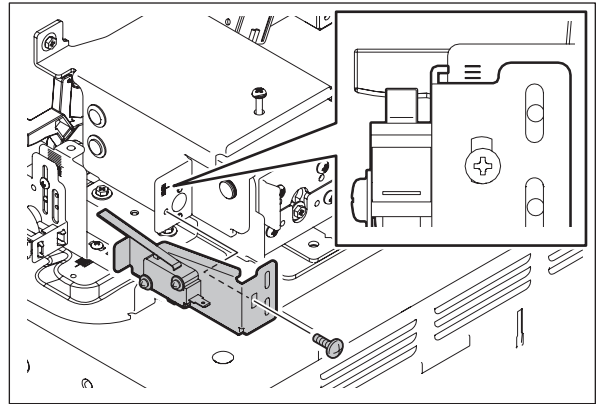

Fig. 15-111

- (4) Remove 1 screw and take off the RADF opening/closing switch.

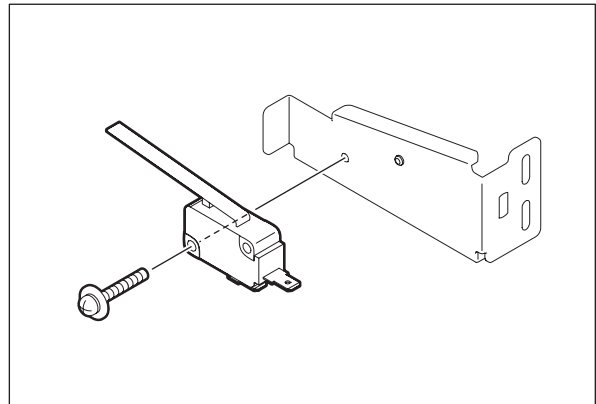

Fig. 15-112

Note:

Be sure to install the switch so that the arm comes to the upper side of the switch.

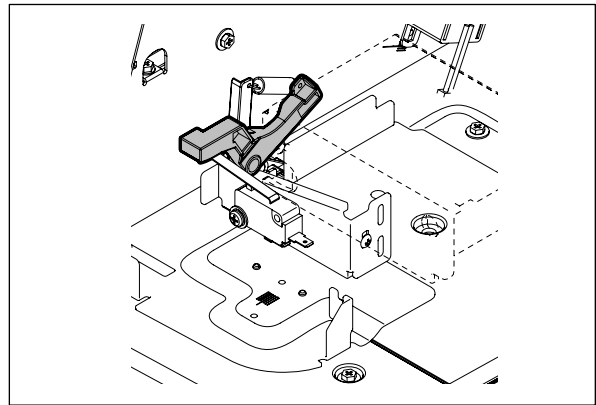

Fig. 15-113

15.5.36 RADF opening/closing sensor (SR15)

- (1) Take off the RADF rear cover.
☞ P.15-58 "15.5.54 RADF board bracket"
- (2) Open the RADF and disconnect 1 connector.
- (3) Release 2 latches and take off the RADF opening/closing sensor.

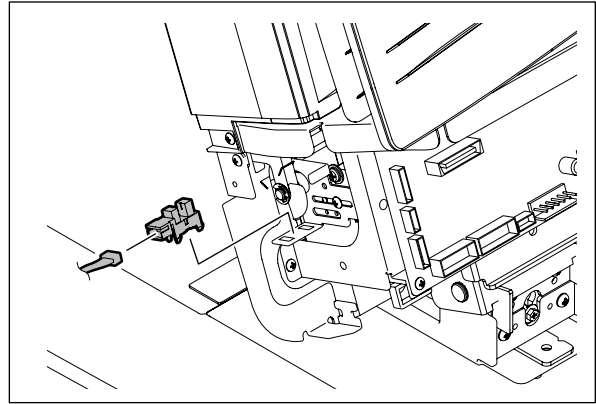

Fig. 15-114

15.5.37 Original empty sensor (SR3)

- (1) Open the original jam access cover.
- (2) Remove 4 screws and take off the sensor bracket.
- (3) Disconnect 1 connector. Release 2 latches and take off the original empty sensor.

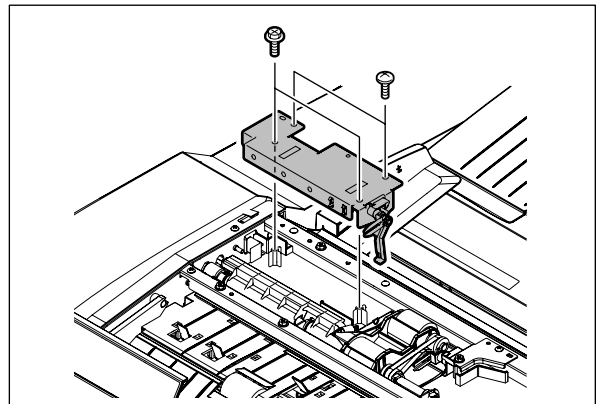

Fig. 15-115

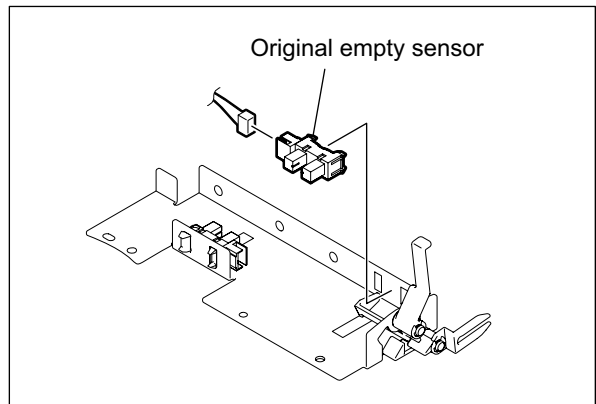

Fig. 15-116

15.5.38 Original jam access cover opening/closing sensor (SR13)

- (1) Open the original jam access cover.
- (2) Remove 4 screws and take off the sensor bracket.

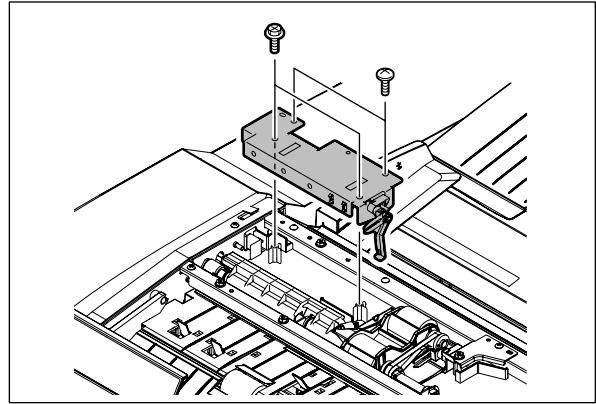

Fig. 15-117

- (3) Disconnect 1 connector. Release 2 latches and take off the original jam access cover opening/closing sensor.

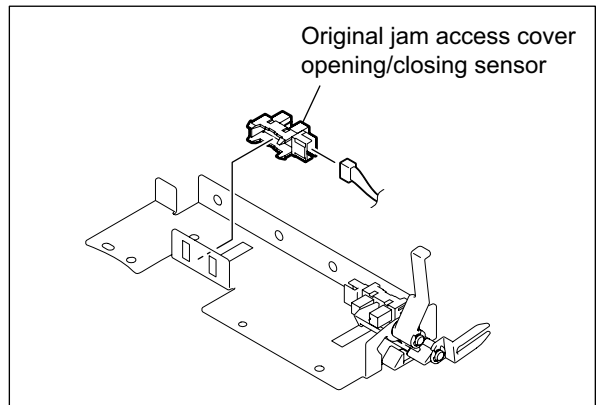

Fig. 15-118

15.5.39 Feeder lower guide unit

- (1) Take off the original tray.
📖 P.15-18 "15.5.6 Original tray"
- (2) Take off the guide.

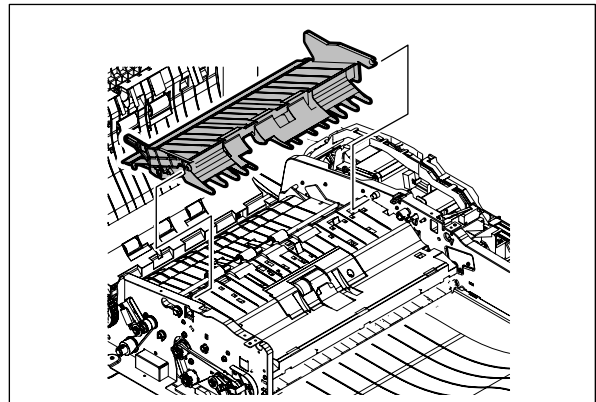

Fig. 15-119

- (3) Remove 4 screws and take off the feeder lower guide unit.

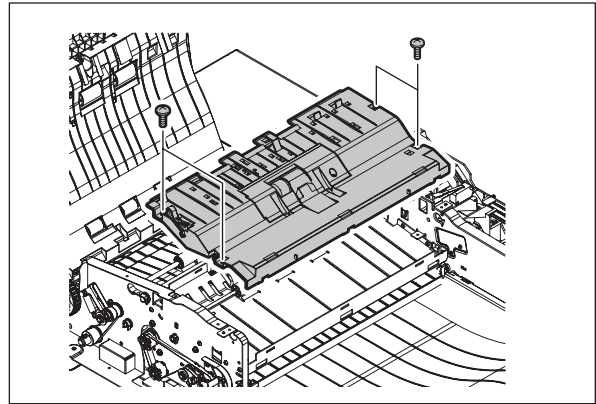

Fig. 15-120

15.5.40 Original width detection sensor-3 (SR8)

- (1) Take off the feeder lower guide unit.
P.15-49 "15.5.39 Feeder lower guide unit"
- (2) Disconnect 1 connector. Lift the actuator, release 2 latches and take off the original width detection sensor-3.

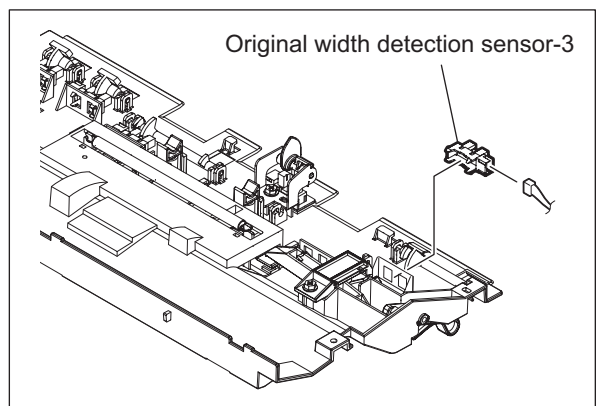

Fig. 15-121

15.5.41 Original width detection sensor-2 (SR7)

- (1) Take off the feeder lower guide unit.
P.15-49 "15.5.39 Feeder lower guide unit"
- (2) Disconnect 1 connector. Lift the actuator, release 2 latches and take off the original width detection sensor-2.

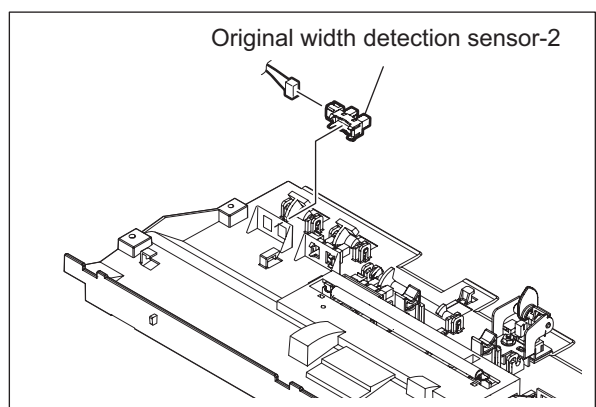

Fig. 15-122

15.5.42 Original width detection sensor-1 (SR6)

- (1) Take off the feeder lower guide unit.
P.15-49 "15.5.39 Feeder lower guide unit"
- (2) Disconnect 1 connector. Lift the actuator, release 2 latches and take off the original width detection sensor-1.

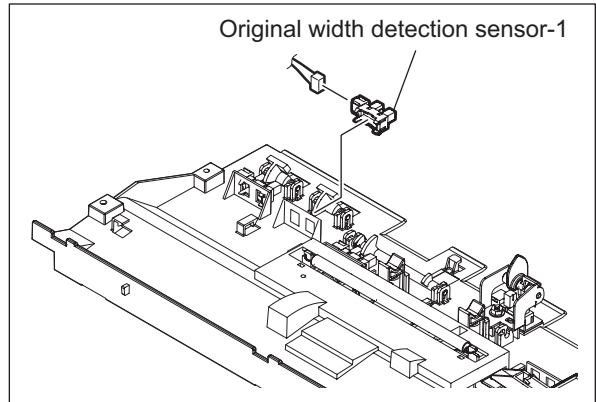

Fig. 15-123

15.5.43 Original registration sensor (SR5)

- (1) Take off the feeder lower guide unit.
P.15-49 "15.5.39 Feeder lower guide unit"
- (2) Disconnect 1 connector. Release 2 latches and take off the original registration sensor.

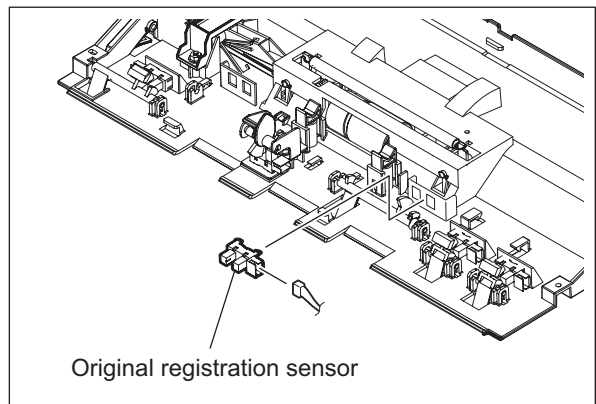

Fig. 15-124

15.5.44 Original exit sensor (SR12)

- (1) Take off the assembly of the exit guide and the exit/reverse guide.
P.15-22 "15.5.11 Exit guide / Exit/reverse guide / Reading end guide"
- (2) Remove 2 screws and take off the 2 leaf springs.

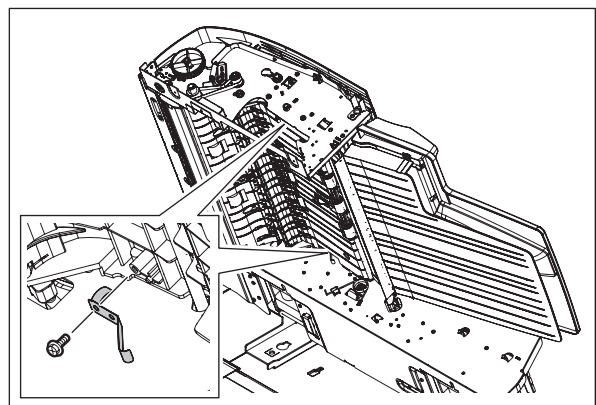

Fig. 15-125

- (3) Remove 3 screws and take off the upper reverse guide.

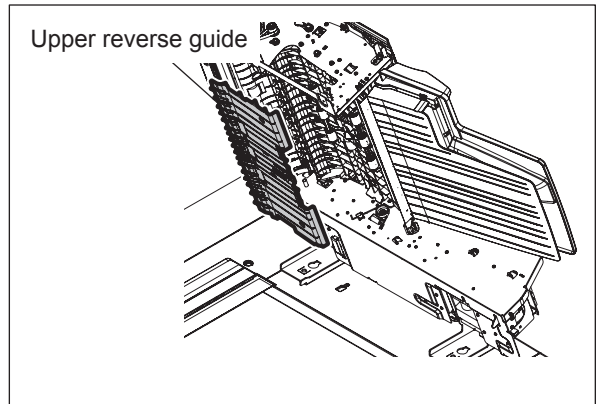

Fig. 15-126

- (4) Disconnect 1 connector. Release 2 latches and take off the original exit sensor.

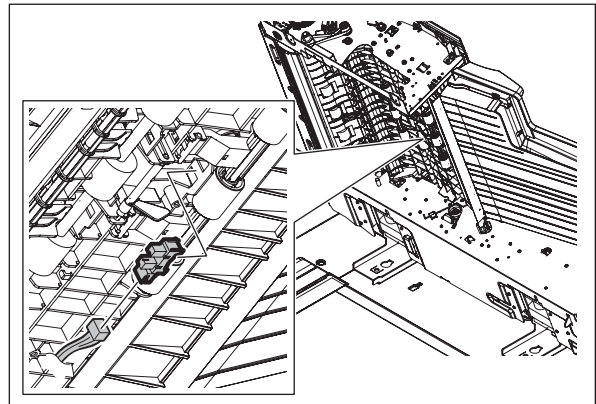

Fig. 15-127

15.5.45 Original tray sensor (SR1)

- (1) Take off the original reverse tray.
P.15-19 "15.5.7 Original reverse tray"
- (2) Remove 2 screws and release 8 latches to take off the original side guide unit.

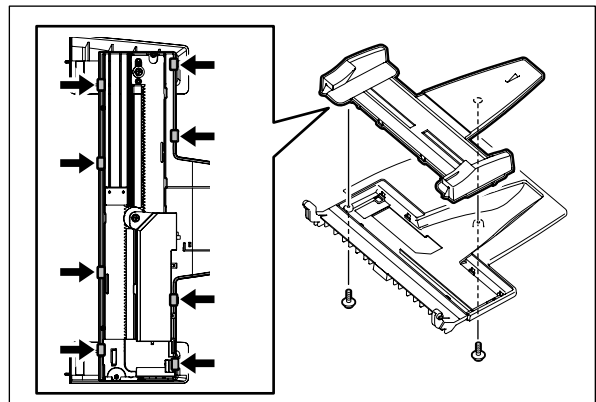

Fig. 15-128

- (3) Remove 2 screws and take off the sensor bracket.

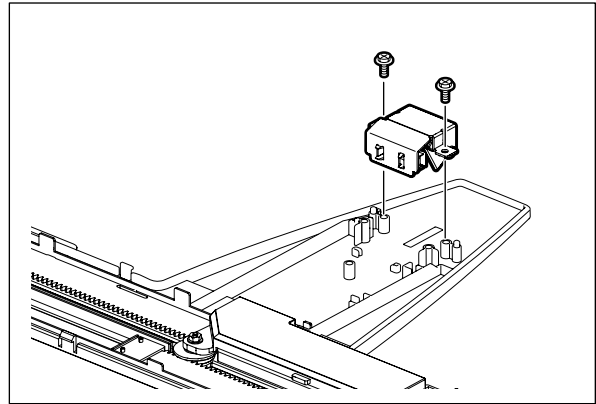

Fig. 15-129

- (4) Disconnect 1 connector. Release 2 latches and take off the original tray sensor.

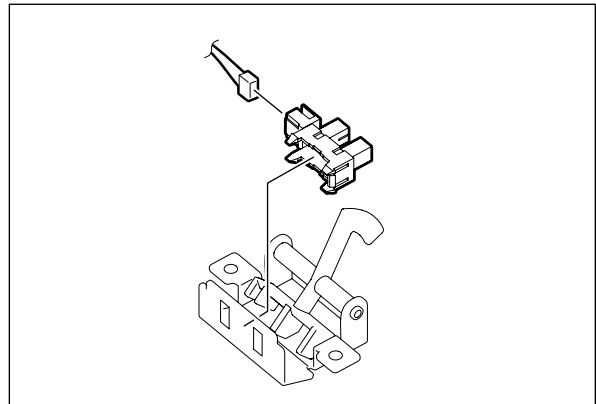

Fig. 15-130

15.5.46 Original tray width sensor (SR2)

- (1) Take off the original reverse tray.
 P.15-19 "15.5.7 Original reverse tray"
- (2) Remove 2 screws and release 8 latches to take off the original side guide unit.

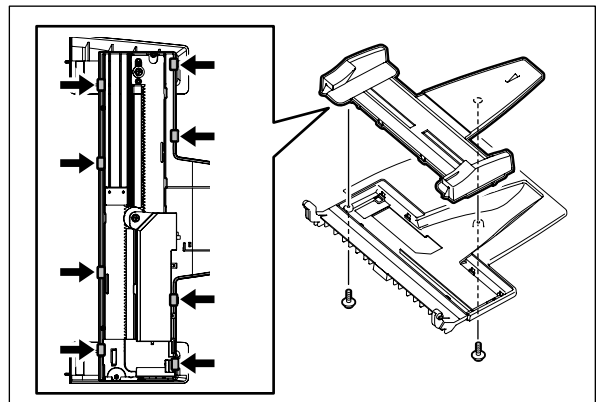

Fig. 15-131

- (3) Remove 1 screw and take off the sensor cover.

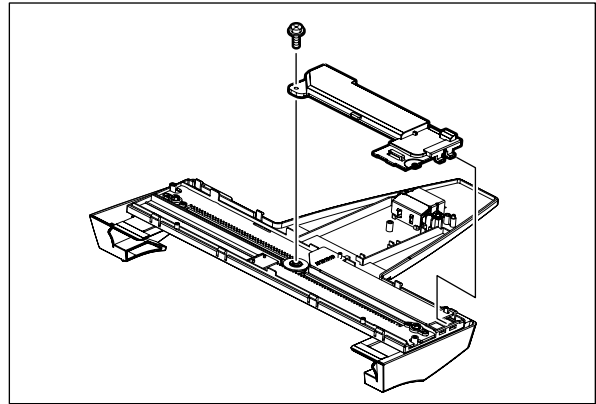

Fig. 15-132

- (4) Disconnect 1 connector and take off the original tray width sensor.

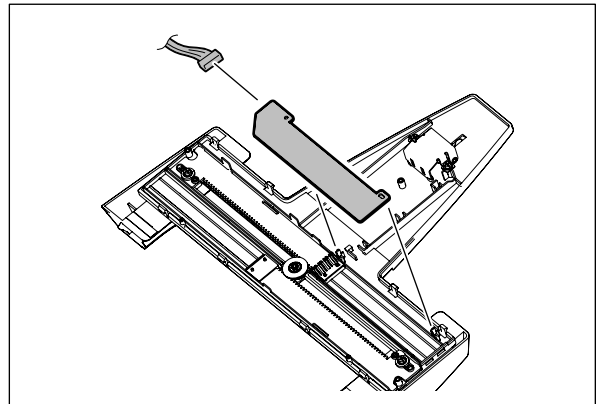

Fig. 15-133

15.5.47 Original exit/reverse sensor (SR11)

- (1) Take off the platen sheet unit.
P.15-19 "15.5.8 Platen sheet unit"
- (2) Remove 1 screw and take off the locking lever on the front side. Remove 1 screw and take off the locking lever on the rear side. Remove 1 spring and take off the locking bracket.

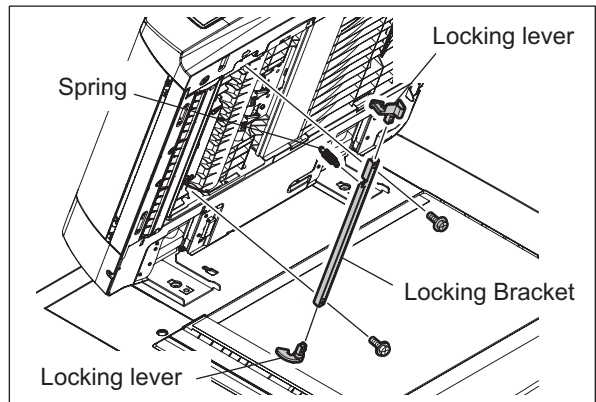

Fig. 15-134

- (3) Remove 2 screws. Disconnect 1 connector and take off the sensor bracket.

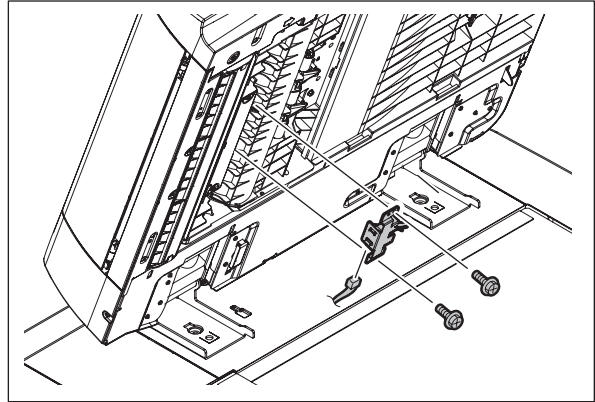

Fig. 15-135

- (4) Release 2 latches and take off the original exit/reverse sensor.

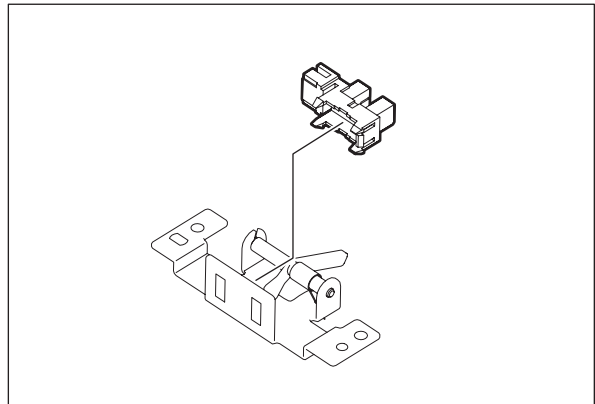

Fig. 15-136

15.5.48 Original reverse unit opening/closing sensor (SR14)

- (1) Take off the reading end guide.
📖 P.15-22 "15.5.11 Exit guide / Exit/reverse guide / Reading end guide"
- (2) Disconnect 1 connector. Release 2 latches and take off the original reverse unit opening/closing sensor.

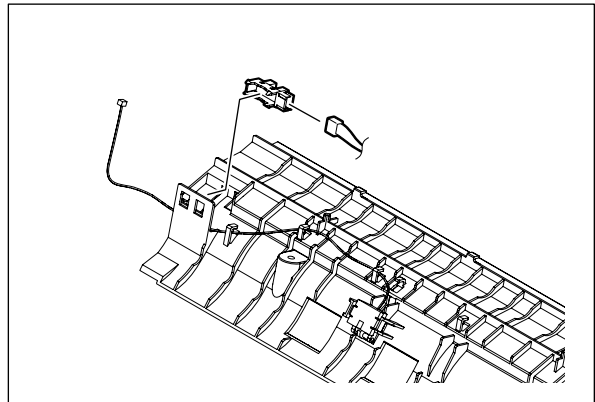

Fig. 15-137

15.5.49 Original reading end sensor (SR4)

- (1) Take off the reading end guide.
P.15-22 "15.5.11 Exit guide / Exit/reverse guide / Reading end guide"
- (2) Disconnect 1 connector. Release 2 latches and take off the original reading end sensor.

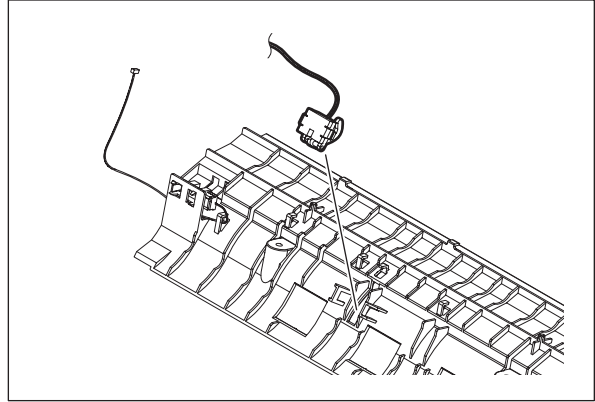

Fig. 15-138

15.5.50 Original intermediate transport sensor (SR9)

- (1) Take off the reading start guide unit.
P.15-21 "15.5.10 Reading start guide unit"
- (2) Release 2 latches and take off the original intermediate transport sensor.

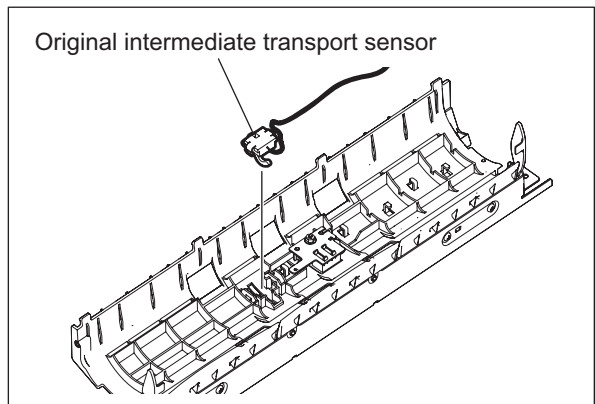

Fig. 15-139

15.5.51 Original reading start sensor (SR10)

- (1) Take off the reading start guide unit.
P.15-21 "15.5.10 Reading start guide unit"
- (2) Disconnect 1 connector. Remove 1 screw and take off the sensor bracket.

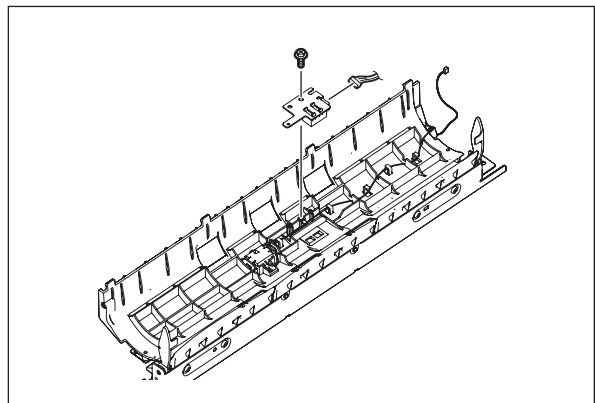



Fig. 15-140

- (3) Release 2 latches and take off the original reading start sensor.

Note:

When replacing the original reading start sensor, be sure to perform the original reading start sensor adjustment.

 SERVICE HANDBOOK "3.12.8 Original reading start sensor adjustment"

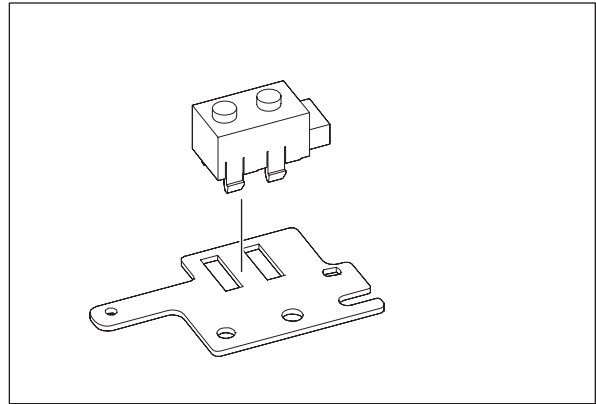



Fig. 15-141

15.5.52 Original reading start sensor (prism)

- (1) Take off the reading start guide unit.
 P.15-21 "15.5.10 Reading start guide unit"
- (2) Remove 4 screws and take off the stay.

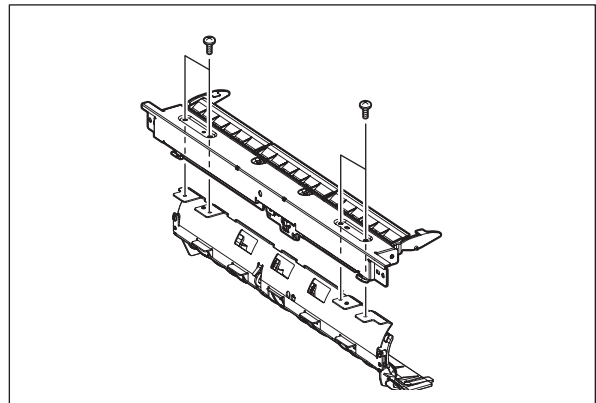



Fig. 15-142

- (3) Remove 2 screws and take off the original reading start sensor prism unit.

Note:

When replacing the original reading start sensor, be sure to perform the original reading start sensor adjustment.

 SERVICE HANDBOOK "3.12.8 Original reading start sensor adjustment"

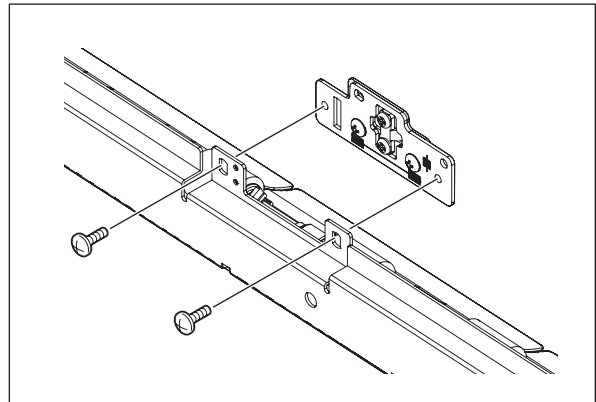



Fig. 15-143

15.5.53 RADF board (RADF)

- (1) Take off the RADF rear cover.
 P.15-16 "15.5.3 RADF rear cover"
- (2) Disconnect 11 connectors. Remove 4 screws and take off the RADF board.

Note:

When replacing the RADF board, be sure to perform the original reading start sensor adjustment.

 SERVICE HANDBOOK "3.12.8 Original reading start sensor adjustment"

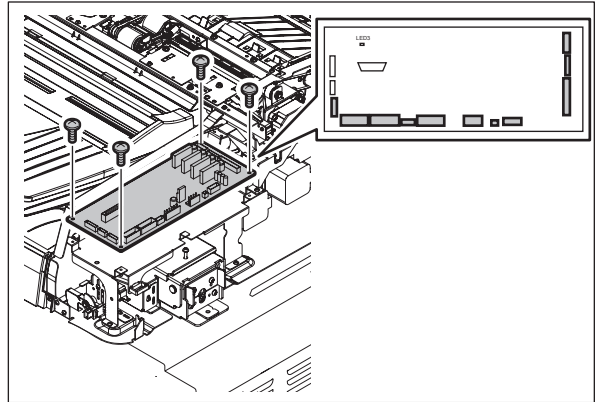



Fig. 15-144

15.5.54 RADF board bracket

- (1) Take off the RADF rear cover.
 P.15-16 "15.5.3 RADF rear cover"
- (2) Disconnect 11 connectors.

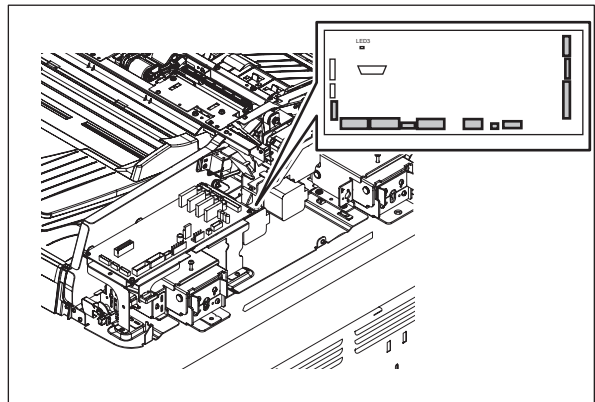

Fig. 15-145

- (3) Disconnect 1 connector. Take off the harness clamp. Remove 4 screws and take off the RADF board bracket.

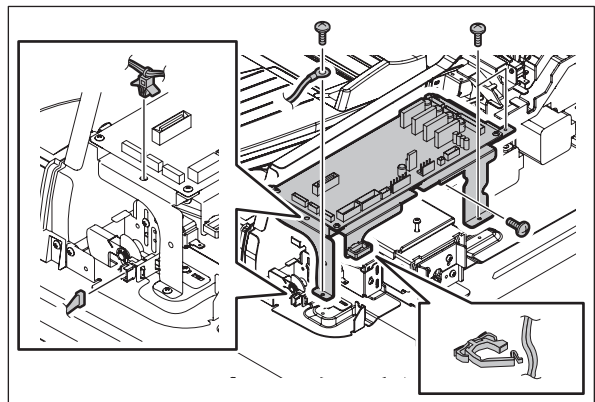

Fig. 15-146

15.5.55 Harness guide

- (1) Take off the RADF rear cover.
📖 P.15-16 "15.5.3 RADF rear cover"
- (2) Remove the harnesses from the harness guide.
- (3) Remove 3 screws and take off the harness guide.

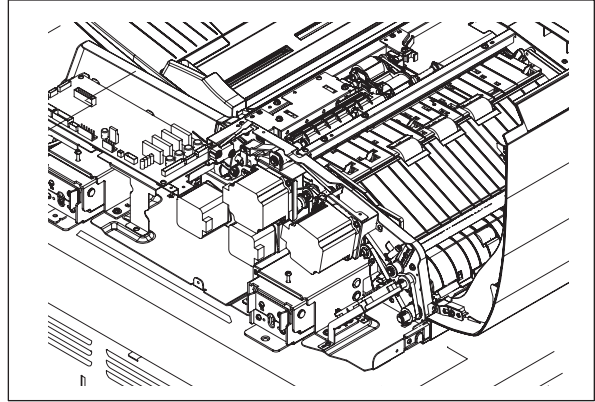

Fig. 15-147

16. POWER SUPPLY UNIT

16.1 Construction

The power supply unit consists of the AC filter and insulation type DC output circuit.

1. AC filter

Eliminates noise from the outside and prevents the noise generated by the equipment from leaking to the outside.

2. DC output circuit

Converts AC voltage input from outside to DC voltage and supplies it to each electric part. The DC voltage is divided into the following two lines.

a. Main switch line: Power supply used in the entire equipment during image forming process. Three kinds of voltage (+3.3 V, +5.1 V and +12 V) are output when the main switch of the equipment is turned ON.

b. Cover switch line: Power supply used in the entire equipment during image forming process, being supplied via the cover switch. Three kinds of voltage (+5.1 V, +24 V and +36 V) are output only when the main switch of the equipment is turned ON and the cover interlock switch is turned ON (front cover (lower) and left lower cover are closed).

16.2 Operation of DC Output Circuit

1. Starting operation of the equipment

When the main switch of the equipment is turned ON, power starts supplying to all the lines only when two covers (front cover and duplexing unit) are closed.

2. Stopping operation of the equipment

When the main switch of the equipment is turned OFF, PER-DN signal is output after the instantaneous outage insurance time (20 ms or more) elapses and then the supply of each voltage stops. If the supply of voltage of the main switch line (+5VS, +5VA, +12VA) stops earlier than the 24 V line does, it may cause the damage of the electron device on each control circuit. To prevent this, the supply of these voltages stops after the PWR-DN signal is output and the minimum retaining time (50 ms) elapses.

3. Normal stopping (shifting to super sleep mode)

When the [ON/OFF] button on the control panel is pressed for 1 second or more while the main switch of the equipment is toggled ON, a super sleep mode shifting/recovering signal (SYS-EN) is output from the SYS board after the initialization is finished and then all lines for output voltage except +5VS are closed.

4. Normal starting (recovering from super sleep mode)

When the [ON/OFF] button on the control panel is pressed for 1 second or more during the super sleep mode, a super sleep mode shifting/recovering signal (SYS-EN) is output from the SYS board and then voltage starts being supplied to all the lines, if no error was detected.

The Super sleep mode is disabled under the following conditions.

- When the Super sleep mode is set to be disabled on the control panel, TopAccess and with the code 08-8543
- When the Wireless LAN Module, Bluetooth Module, e-BRIDGE ID Gate or Data Overwrite Enabler is installed, or when the IPsec Enabler is installed and its function is set to be enabled
- When the setting for receiving confidential data on each line (08-3846) is set to ON
- When operation is being performed in the self-diagnosis mode (Disabled until the main switch is turned OFF)

5. Output protection

Each output system includes an overcurrent and overvoltage protection circuits (a fuse and internal protection circuit). This is to prevent the defectives (damage or abnormal operation of the secondary circuit) which may be caused by an overcurrent due to a short circuit or an overvoltage due to a short circuit between different voltages. If the protection circuit is activated (except the case the fuse is blown out), remove the causes such as short-circuit. Turn ON the power again 1 minute later to clear the overcurrent protection.

6. State of the power supply

- Power OFF

The main power switch of the equipment is turned OFF. Since DC voltage is not supplied to each board, the equipment is not operable.

- Normal state (including Energy saving mode)

The main power switch of the equipment is turned ON and DC voltage is supplied to each board. When the cover of the equipment is closed, 24V DC voltage is supplied and the equipment enters into the ready/printing state.

- Sleep mode

Since +3.3VB, +5VB, +5VD, +12VB and +24V DC voltages are not supplied but +12VA, +5VA and +5VS DC voltages only, the equipment does not enter into the ready state.

- Super Sleep mode

Only DC voltage and +5VS are output from the power supply unit. The [POWER] button is monitored and the LED of the main power switch is lit.

16.3 Output Channel

The following are 3 output channels for the main switch line.

1. +3.3 V

- +3.3VB: CN406 Pin 1
Output to the LGC board
- +3.3VB: CN407 Pin 5
Output to the PLG board
- +3.3VB: CN408 Pin 1
Output to the SLG board

2. +5.1 V

- +5VS: CN405 Pins 9 and 10
Output to the SYS board
- +5VA: CN405 Pins 12 and 13
Output to the SYS board
- +5VB: CN405 Pin 20
Output to the SYS board
- +5VB: CN406 Pin 2
Output to the LGC board, external LCF (via LGC board),
IPC board (finisher: via LGC board)
- +5VB: CN407 Pins 1 and 2
Output to the PLG board
- +5VB: CN408 Pins 3 and 4
Output to the SLG board
- +5VB: CN409 Pin 1
Output to the finisher

3. +12 V

- +12VA: CN405 Pins 15 and 16
Output to the SYS board
- +12VB: CN405 Pin 19
Output to the SYS board, FAX unit (via SYS board)
- +12VB: CN406 Pin 6
Output to the LGC board
- +12VB: CN407 Pin 6
Output to the PLG board
- +12VB: CN408 Pin 7
Output to the SLG board

The following are 3 output channels for the cover switch line.

1. +5.1 V

+5VD: CN403 Pin 5
Output to the PLG board

2. +24 V

+24VD1: CN402 Pins 2 and 3
Output to the LGC board, external LCF (via LGC board)

+24VD2: CN402 Pin 1
Output to the LGC board

+24VD2: CN403 Pin 1
Output to the PLG board

+24VD2: CN404 Pin 3
Output to the SLG board

+24VD3: CN409 Pins 3 and 4
Output to the finisher

+24VD4 CN404 Pins 5 and 7
Output to the RADF

3. +36 V

+36VD: CN402 Pins 7 and 8
Output to the LGC board

+36VD: CN403 Pin 3
Output to the PLG board

+36VD: CN404 Pin 1
Output to the SLG board

Output voltage by the type of connector

Main switch line

Connector	Destination	Voltage
CN405	For the SYS board, FAX unit (via SYS board)	+5VA, +5VB, +5VS, +12VA, +12VB
CN406	For the LGC board, external LCF (via LGC board), finisher (via LGC board)	+3.3VB, +5VB, +12VB
CN407	For the PLG board	+3.3VB, +5VB, +12VB
CN408	For the SLG board	+3.3VB, +5VB, +12VB
CN409	For the finisher	+5VB

Cover switch line

Connector	Destination	Voltage
CN402	For the LGC board, external LCF (via LGC board)	+24VD1, +24VD2, +36VD
CN403	For the PLG board	+5VD, +24VD2, +36VD
CN404	For the SLG board, RADF	+24VD2, +24VD4, +36VD
CN409	For the finisher	+24VD3

16.4 Fuse

When the power supply secondary fuse is blown out, confirm that there is no abnormality with each part using the following table.

Voltage	Board/unit	Part	Fuse type			
+24VD1	LGC board	Web motor	M4	F4: 8A (Semi time-lag)		
		New toner supply motor	M5			
		New toner transport motor	M6			
		Hopper motor	M7			
		Recycle toner transport motor	M8			
		Used toner transport motor	M9			
		Wire cleaner drive motor	M12			
		Cleaning brush drive motor	M13			
		Transfer belt cam motor	M15			
		Transport motor	M17			
		Exit motor	M18			
		Reverse motor	M19			
		Auto-toner sensor	S12			
		Drum surface potential sensor	S13			
		Main switch	SW6			
		High-voltage transformer	HVT			
		Discharge LED	ERS			
		+24VD1	LGC board		Registration motor	M16
Tray-up motor-1	M21					
Tray-up motor-2	M22					
Reverse section cooling fan-1	M24					
Reverse section cooling fan-2	M25					
IH board cooling fan	M26					
Duct out fan	M27					
Exit section cooling fan	M29					
Tandem LCF tray-up motor	M41					
Tandem LCF end fence motor	M42					
Horizontal transport section driving clutch-1	CLT1					
Horizontal transport section driving clutch-2	CLT2					
Horizontal transport section driving clutch-3	CLT3					
Bypass feed clutch	CLT4					
1st drawer transport clutch	CLT5					
1st drawer feed clutch	CLT6					
2nd drawer transport clutch	CLT7					
2nd drawer feed clutch	CLT8					
3rd drawer transport clutch	CLT9					
3rd drawer feed clutch	CLT10					
4th drawer transport clutch	CLT11					
4th drawer feed clutch	CLT12					
Gate solenoid	SOL2					
Bypass pickup solenoid	SOL3					
Tandem LCF pickup solenoid	SOL7					
Tandem LCF end fence solenoid	SOL8					
	External LCF					
+24VD2	LGC board	Developer unit motor	M10	F5: 8A (Semi time-lag)		
		Fuser cooling fan	M28			
		Duct in fan	M30			
		Developer unit fan	M31			
		Laser unit cooling fan	M32			
		Switching regulator cooling fan-1	M34			
		Switching regulator cooling fan-2	M35			
		Drum separation finger solenoid	SOL1			
			Copy key card			

Voltage	Board/unit	Part		Fuse type
+24VD2	PLG board	Polygonal motor (Only for e-STUDIO755/855 model)	M2	F5: 8A (Semi time-lag)
+24VD2	SLG board	SLG board cooling fan	M23	F5: 8A (Semi time-lag)
		Lamp inverter board	INV-EXP	
+24VD2	Finisher			F6: 8A (Semi time-lag)
+24VD4	RADF			F7: 8A (Semi time-lag)
+36VD	LGC board	Fuser motor	M3	F8: 8A (Semi time-lag)
		Feed motor	M20	
+36VD	LGC board	Drum motor	M11	F8: 8A (Semi time-lag)
		Transfer belt motor	M14	
+36VD	PLG board	Polygonal motor (Only for e-STUDIO555/655 model)	M2	F8: 8A (Semi time-lag)
+36VD	SLG board	Scan motor	M1	F8: 8A (Semi time-lag)
+5VB	LGC board	Harnesses and sensors to be connected to the LGC board	---	F9: 3.15A (Semi time-lag)

16.5 Configuration of Power Supply Unit

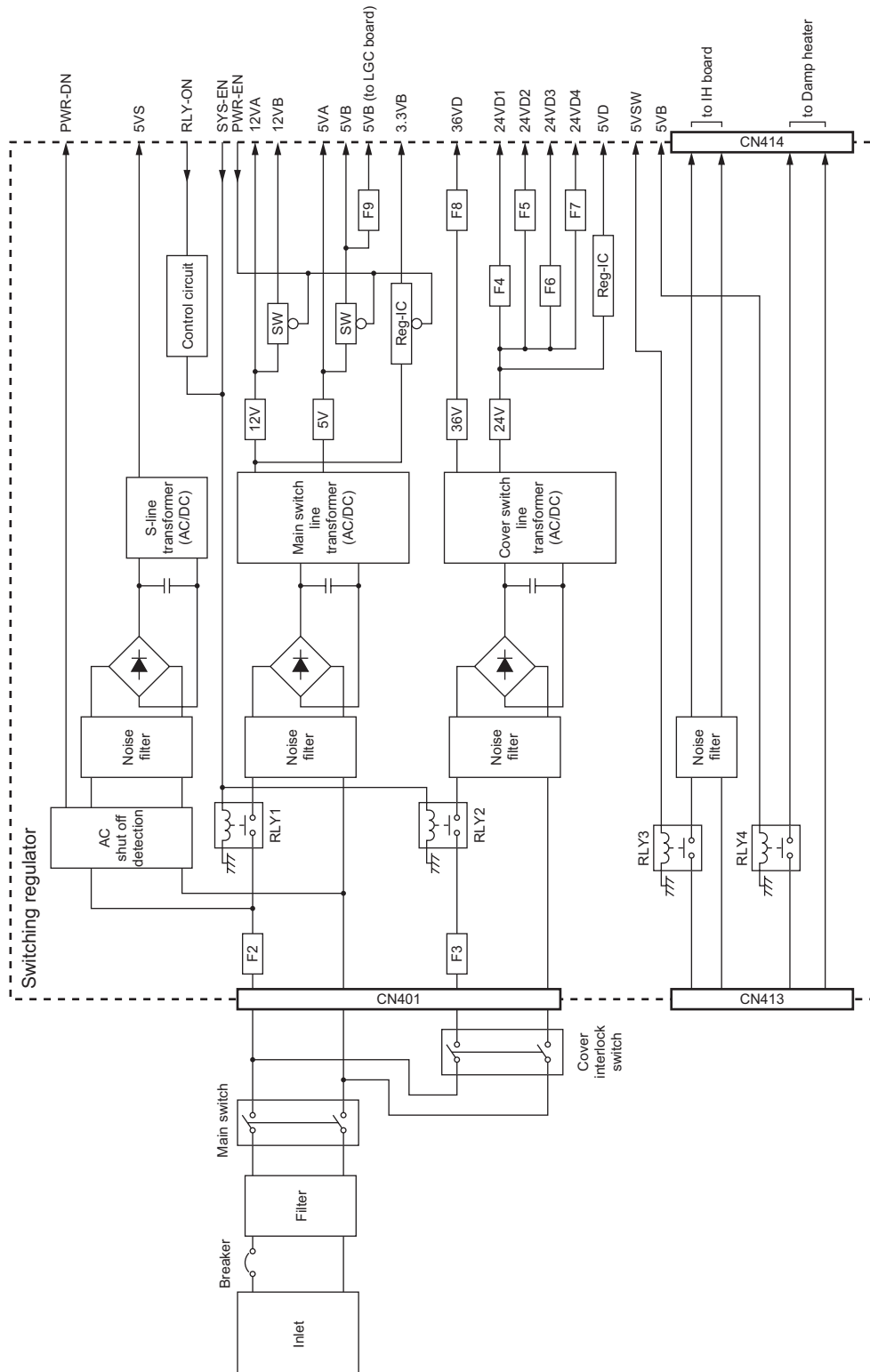

Fig. 16-1

16.6 AC Wire Harness

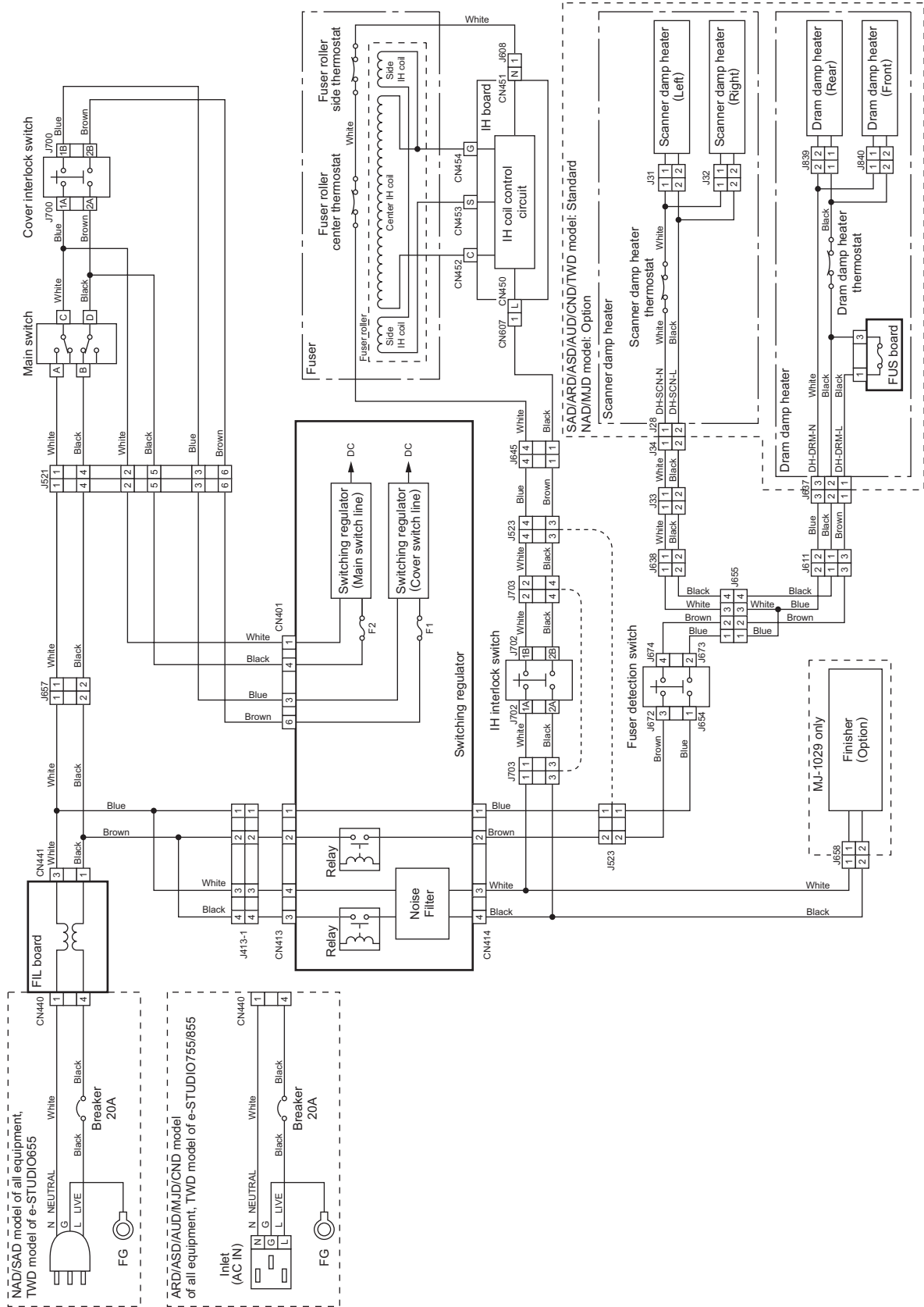

Fig. 16-2

17. PC BOARDS

1. PWA-F-SYS

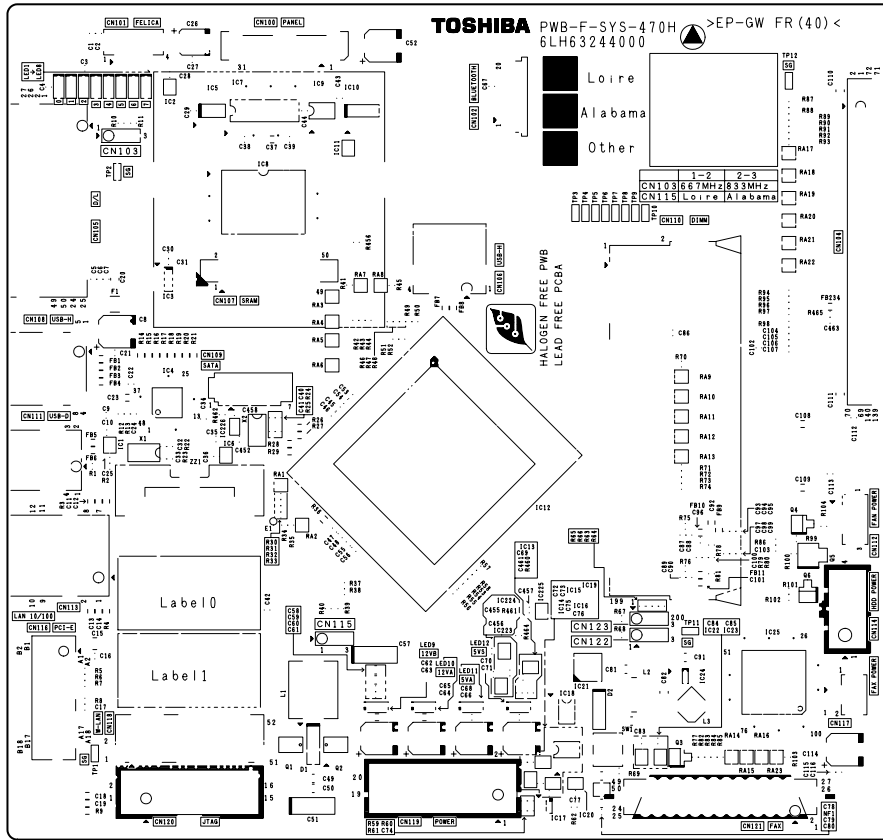

Fig. 17-1

2. PWA-F-SYSIF

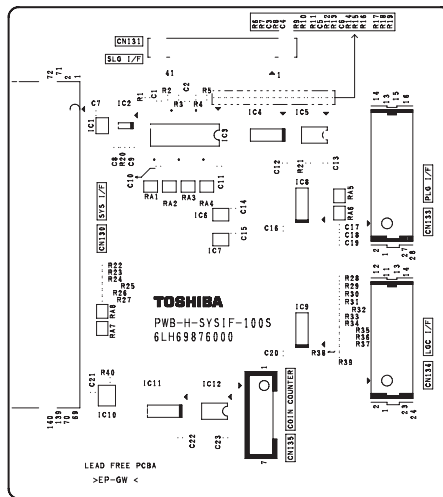

Fig. 17-2

3. PWA-H-LGC

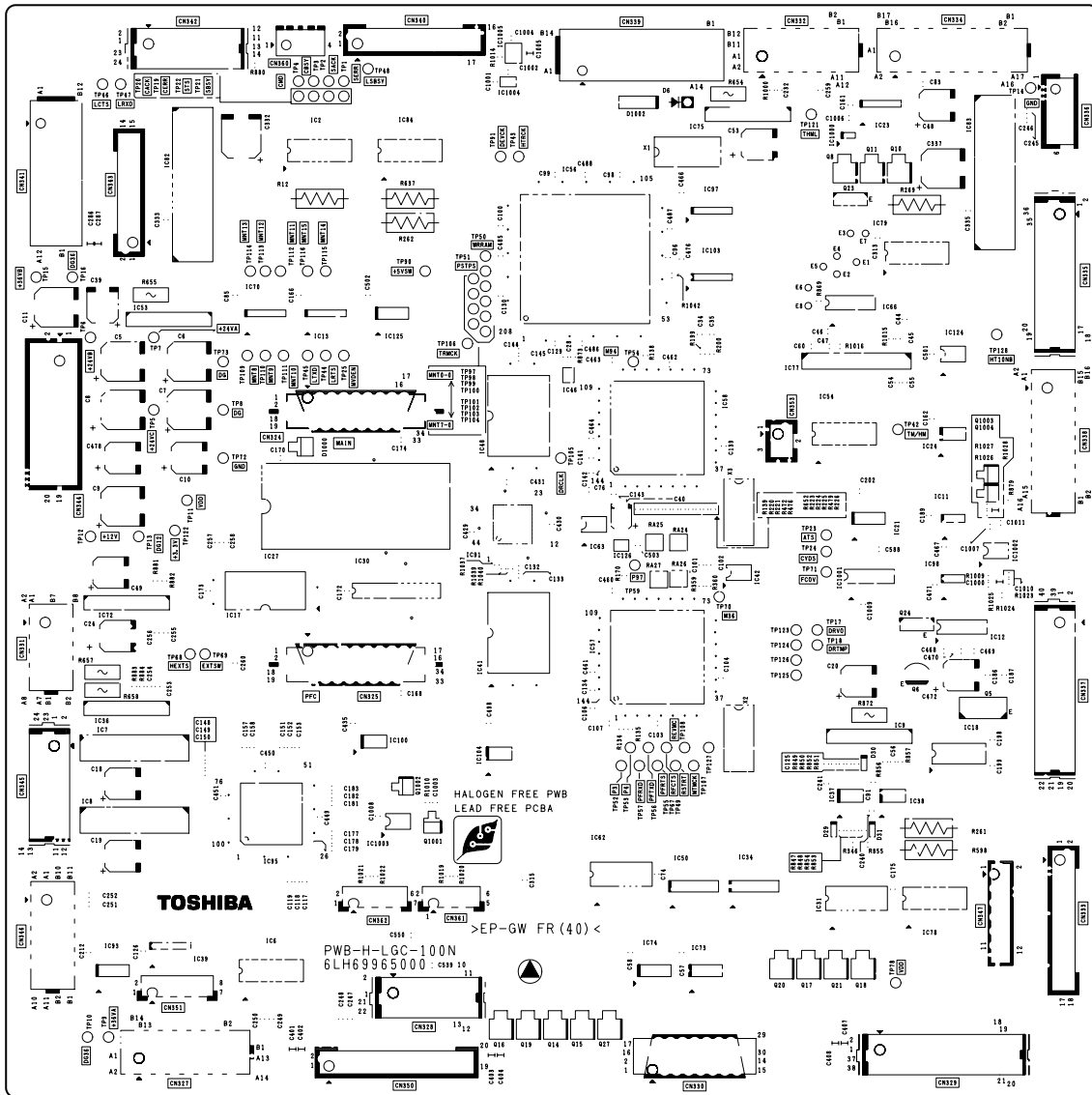

Fig. 17-3

4. PWA-F-CCD

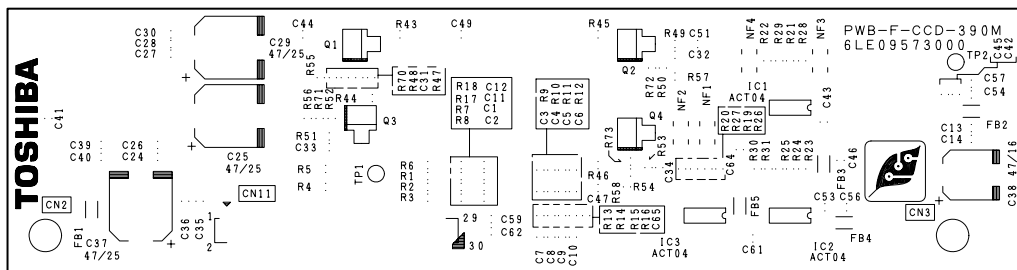

Fig. 17-4

5. PWA-F-SLG

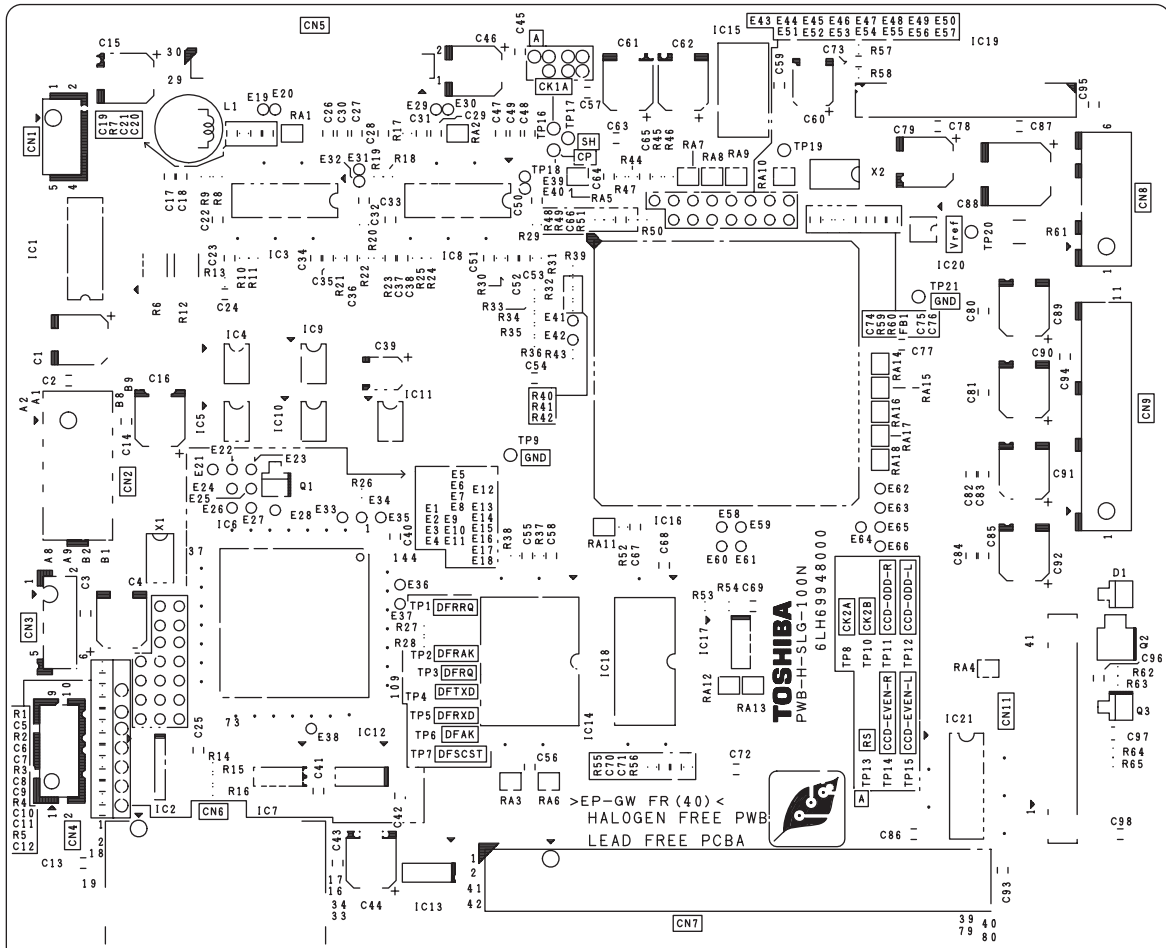

Fig. 17-5

6. PWA-H-PLG

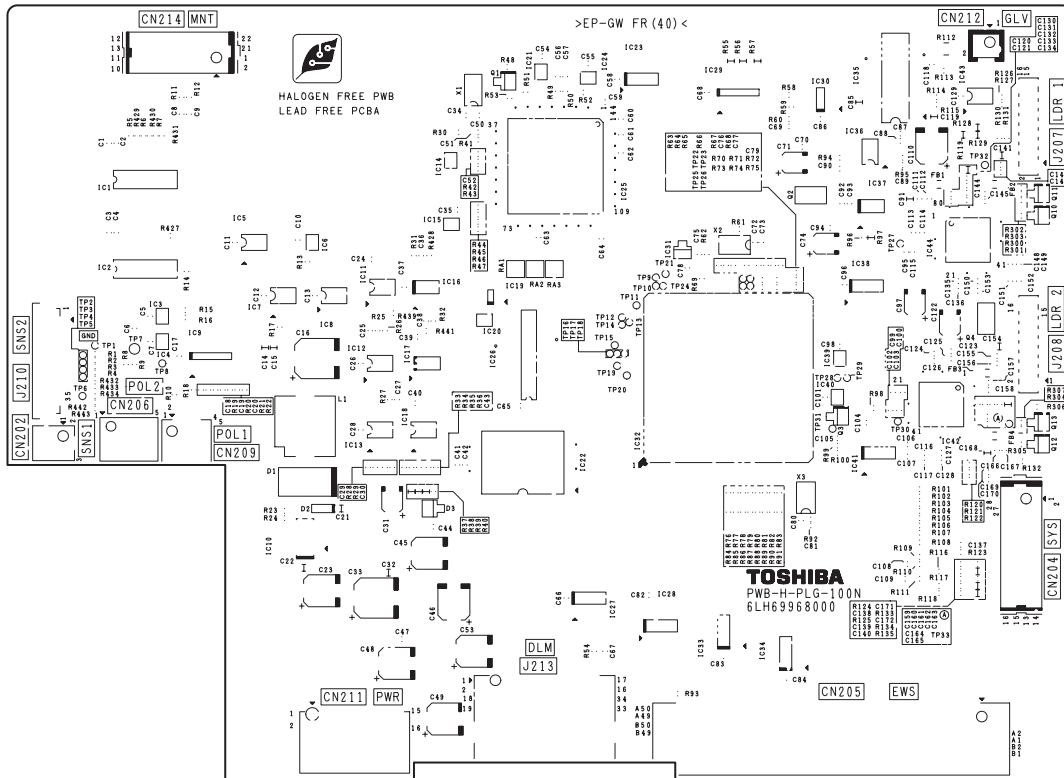

Fig. 17-6

7. PWA-F-LDR

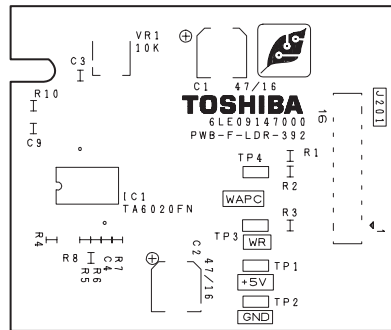

Fig. 17-7

8. PWA-F-SNS

* Only for e-STUDIO555/655

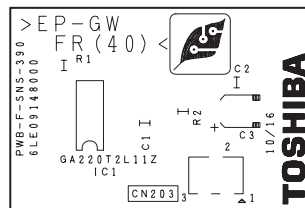

Fig. 17-8

9. PWA-F-SNS

* Only for e-STUDIO755/855

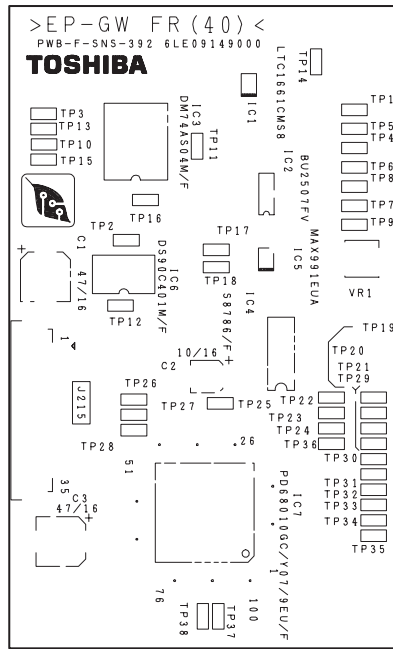

Fig. 17-9

10. PWA-F-MOT

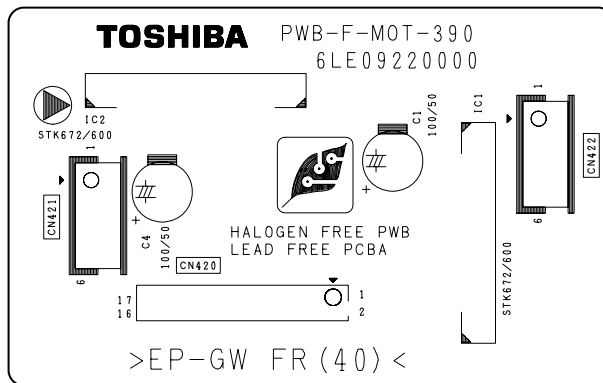

Fig. 17-10

11. PWA-F-MOT2-MT/RV

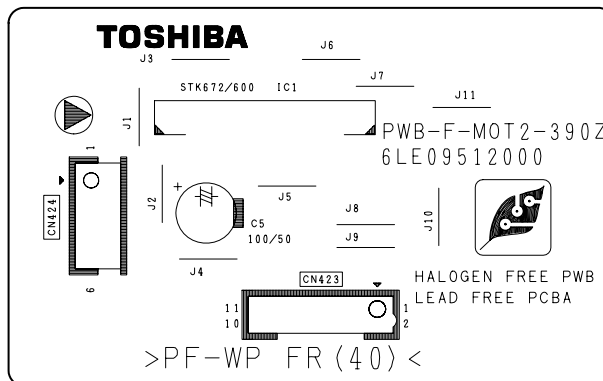

Fig. 17-11

12.PWA-F-DSP

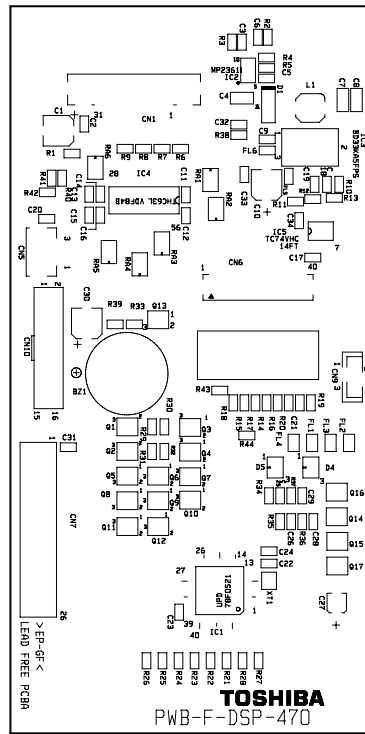

Fig. 17-12

13.PWA-F-KEY

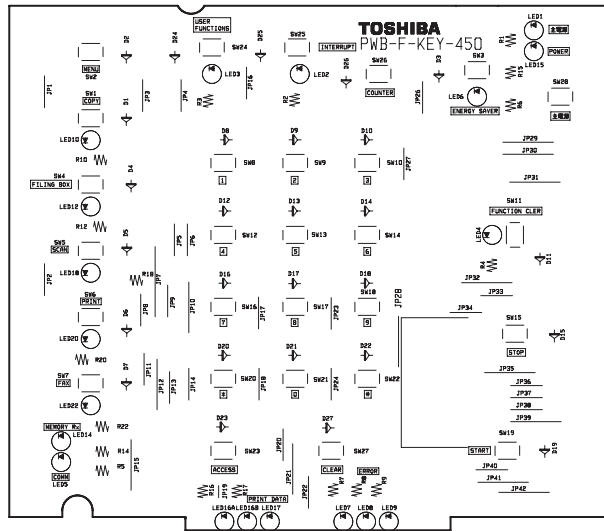

Fig. 17-13

14.PWA-F-FUS

* Optional for NAD/MJD model, standard for other models

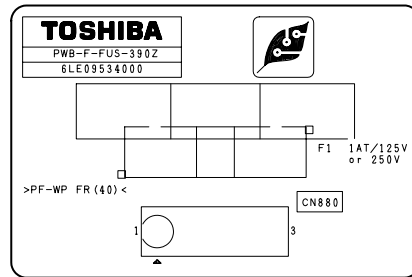

Fig. 17-14

15.PWA-F-FIL

* Only for NAD/SAD/ARD/ASD/AUD/MJD/CND/TWD model

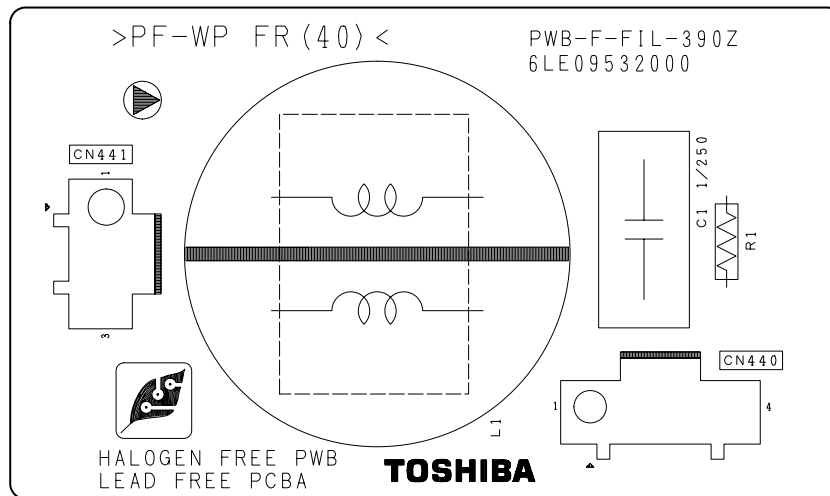

Fig. 17-15

18. EXTERNAL COUNTERS

18.1 Outline

This specification describes the interface between external counters, such as Coin Controller and Key Counter.

18.2 Signal

[A] Pin Layout

1. Connector on the LGC board: CN343 (Coin Controller / Card Controller)

Pin No.	I/O	Signal name	Function	Voltage level	Remarks	GQ-1240	GQ-1050	GQ-1060
1	Power	+24VB	24V line	DC24V±10%	When cover opened: OFF	In use	In use	In use
2	Out	TORON	Total Counter On Signal	Open Collector (IC54)	L: ON	In use	In use	In use
3	In	KCTRC	Copy permission Signal 1	L=0V, H=DC5V (IC56)	L: Allowed	-	-	-
4	Out	MCRUN	Ready to Copy Signal	Open Collector (IC70)	L: Operating	In use	In use	-
5	Out	EXTCTR	Exit Sensor On Signal	Open Collector (IC70)	L: ON	In use	-	-
6	GND	DG	Power ground	0V		In use	-	-
7	Out	BKCTR	Drawer feed Counter Signal	Open Collector (IC70)	L: ON	-	In use	-
8	Out	MNCTR	ADU feed mode Counter Signal	Open Collector (IC70)	L: ON	-	In use	-
9	GND	SG	Signal ground	0V		-	In use	In use
10	Out	SIZE0	Paper size Signal	Open Collector (IC70)	L: ON	-	In use	-
11	Out	SIZE1	Paper size Signal	Open Collector (IC70)	L: ON	-	In use	-
12	Out	SIZE2	Paper size Signal	Open Collector (IC13)	L: ON	-	In use	-
13	Out	SIZE3	Paper size Signal	Open Collector (IC13)	L: ON	-	In use	-
14	Power	VDD	5V line	DC5V±3%	At the sleep mode:OFF	In use	In use	In use
15	In	CTRCN2	Counter connection Signal 2	L=0V, H=DC5V	L: Connecting	In use	In use	In use

2. Connector on the SYSIF board: CN135 (Coin Controller)

Pin No.	I/O	Signal name	Function	Voltage level	Remarks
1	Out	L/S	Paper size Signal	Open Drain (IC12)	L: Large size
2	Out	FULL-C	Full color mode Signal	Open Drain (IC12)	L: Full color
3	Out	MONO-C	Twin color / Mono color Mode Signal	Open Drain (IC12)	L: Twin colors
4	Out	B/W	Black mode Signal	Open Drain (IC12)	L: Black
5	-	N.C.	-	-	
6	GND	GND	Signal Ground	0V	
7	-	N.C.	-	-	

*: FULL-C, MONO-C and B/W are exclusively for color copy and not provided for this equipment.

3. Counter on the LGC board: CN339 / Counter on the harness: J590 (Key Counter)

Pin No. (CN339)	Pin No. (J590)	I/O	Signal name	Function	Voltage level	Remarks
A4	1	GND	SG	Signal Ground	0V	
A3	2	In	KCTRC	Key Counter Connection Signal	L=0V, H=DC5V (IC54)	L: Connected H: Not connected
A2	3	Power	+24VA	24V line	DC24V±10%	When cover opened: OFF
A1	4	Out	KCTRON	Key Counter On Signal	Open Collector (IC54)	L: ON

[B] Details of the signals

1. TORON signal and KCTRON signal (output signals)

The TOLON signal is a count signal synchronized with an electronic counter for the equipment. This signal is turned to a low level (ON) every time the counter counts up.

This output signal also drives each mechanical counter directly.

* If "1" or "2" is set for the setting code 08-352 (counter setting for large-sized paper), a sheet of large-sized paper is counted as two sheets only when the KCTRON signal is turned to a low level. The CTRON signal, which is output from the LGC board, is used for both copy key cards and coin controllers.

The KCTRON signal also output from the LGC board is for key copy counters.

2. KCTRC signal (input signal)

This signal is a connection signal that detects whether each counter is installed or not. The counter is installed when this signal is at a low level.

When this signal is at a high level, copying with the counter is disabled.

Note that the loop of the counter harness (J590) must be cut off and the signal turned to a high level when a key copy counter is installed. (The loop does not need to be cut off and the signal must be kept at a low level when a copy key card or a coin controller is installed.)

This signal is used commonly among key copy counters, copy key cards and coin controllers.

3. MCRUN signal (output signal)

This signal is turned to a low level while the equipment performs copying.

When copying is interrupted due to forcible toner supply or another reason, however, this signal remains at a high level until the equipment becomes ready for copying again.

This signal, which is output from the LGC board, is used for both copy key cards and coin controllers.

4. EXTCTR signal (output signal)

This signal is turned ON, since it is synchronized with the turning OFF of the exit sensor.

A coin controller counts up the degree of usage of copy cards by means of this signal.

This signal, which is output from the LGC board is used only for coin controllers.

5. BKCTR signal, MNCTR signal (input signal)

The BKCTR signal is turned to a low level (ON), it is synchronized with the TOLON signal when paper is fed from a drawer or the bypass tray. This signal is for counting print jobs for the front side of the paper.

The MNCTR signal is turned to a low level (ON), it is synchronized with the TORON signal when paper is fed from the ADU. This signal is for counting print jobs for the back side of the paper.

This signal, which is output from the LGC board is used only for copy key cards.

6. SIZE3, SIZE2, SIZE1, SIZE0 signal (output signal)

These four signals are output in combination corresponding to the size of the copy paper.

This signal, which is output from the LGC board, is used only for copy key cards.

7. CTRCN2 signal (output signal)

This signal enables copying with each counter. Copying is enabled when this signal is at a low level. Copying is disabled when it is at a high level.

This signal is used for both copy key cards and coin controllers.

8. L/S signal (output signal)

When large size paper (A3 / A3 wide / LD) is selected or paper size is not specified with the manual feeding, it outputs "Low" in real time. In other cases, it outputs "High". The setting change for large size paper is performed with F/W.

This is the signal only for the coin controller.

9. B/W signal (output signal)

If the black mode is selected, it outputs "Low" in real time. In other cases, it outputs "High". This is the signal only for the coin controller.

18.3 Notices

[A] Setting code

Each signal will be enabled by configuring the setting code "08-202" (Counter installed externally).

08-202

- 0: No external counter (Default)
- 1: Coin controller
- 2: Card controller (For Japan only)
- 3: Key copy counter
- 4: Card controller for OEM1

[B] Setting value change and restrictions when using the Card controller

1. Setting value

- 08-202 (Counter installed externally): Set to "2" (Card controller).
- 08-381 (Setting for counter installed externally): It should be charged precisely according to the usage.
Example: To charge only when copies are made, set to "1".

2. Restrictions

- 08-352 (Large size double count setting): Set to "0" (Single count).

[C] Setting value change and restrictions when using the coin controller

1. Setting value

- 08-202 (Counter installed externally): Set to "1" (Coin controller).
- 08-381 (Setting for counter installed externally): It should be charged precisely according to the usage.
Example: To charge only when copies are made, set to "1".

2. Restrictions

For 08-353 (Large size double count setting), set to "0" when A3 and LD are specified as the large size, and set to "1" when B4, LG, FOLIO and COMP are specified as the large size in addition to A3 and LD.

[D] Setting value change and restrictions when using the key counter

1. Setting value

- 08-202 (Counter installed externally): Set to "3" (key counter)
- 08-381 (Setting for counter installed externally): It should be charged precisely according to the usage.
Example: To charge only when copies are made, set to "1".

2. Restrictions

For 08-353 (Large size double count setting), set to "0" when A3 and LD are specified as the large size, and set to "1" when B4, LG, FOLIO and COMPUTER are specified as the large size in addition to A3 and LD.

[E] Installation of External Counter

It is not allowed to install more than one external counter (Key Counter, Card controller and Coin controller) at the same time. Physically, the card controller and coin controller cannot be installed together since the output signals are in common.

REVISION RECORD

Ver.05

Ver.05<2011.4.25>	
Page	Contents
Trademarks	The descriptions of Windows 95, 98, Me and 2000 have been deleted. The description of Windows 7 has been added.
9-1	The chapter numbers have been corrected.
12-1	The chapter number has been corrected.
16-8	The AC wire harness connection diagram (Fig. 16-2) has been replaced.

Ver.04

Ver.04 <2010.12.8>	
Page	Contents
5-7	A message item "101" has been added to the table.

Ver.03

Ver.03 <2010.1.21>	
Page	Contents
Precaution	The label illustration has been added.
1-1	TWD model has been corrected.
18-1	Signal name has been corrected.

Ver.02

Ver.02<2009.10.2>	
Page	Contents
PRECAUTIONS	The value for the voltage/current has been added.
PRECAUTIONS	The value for the voltage/current has been added.
1-2	The paper size "Full Bleed 12x18" for the drawer has been deleted.
1-3	The value for the voltage/current has been added to the power requirements.
1-16	The destination of the power cable has been corrected.
2-7	S53 has been added to Fig. 2-5.
2-8	S53 has been added to Fig. 2-6.
2-35	S53 has been added to the list.
6-11	The name has been corrected from "APS operation sensor" to "Platen sensor".
6-24	The disassembling procedure of the platen sensor has been added.
9-11	"Note" for the screws to fix the motor has been added.
10-14	"Note" for the screws to fix the motor has been added.
11-13	"Note" for the screws to fix the motor has been added.
11-15	"Note" for the screws to fix the motor has been added.
11-16	"Note" for the screws to fix the motor has been added.
11-27	"Note" for the screws to fix the motor has been added.
12-13	"Note" for the screws to fix the motor has been added.
13-6	The numbers of the counter for C490 and C474 have been exchanged.
13-28	"Note" for the screws to fix the motor has been added.
17-3	Fig. 17-5 (drawing of the SLG PC board) has been changed.

Ver.01

Ver.01 <2009.7.8>	
Page	Contents
1-1	The applicable destination for the Tandem LCF has been corrected.
1-17	GQ-1040 has been corrected to GQ-1240.
3-1	The model name has been corrected.
13-7	The model name has been corrected.
13-8	The model name has been corrected.
13-11	The value "19" has been corrected to "21" in the table.
13-15	A note for assembling the fuser unit has been added.
18-1	The chapter "EXTERNAL COUNTERS" has been added.

TOSHIBA

TOSHIBA TEC CORPORATION

2-17-2, HIGASHIGOTANDA, SHINAGAWA-KU, TOKYO, 141-8664, JAPAN